

HOW TO ASSEMBLE

HORIZON 4 x 4.6m

IMPORTANT!

Please read these instructions carefully before starting assembly. Keep these instructions in a safe place for future reference.

www.primehort.co.nz



BASE DIMENSIONS HORIZON

MODEL	HORIZON	
WIDTH	A	380 cm / 12'5"
	C	303 cm / 9'11"
LENGTH	B	454 cm / 14'9"
	D	303 cm / 9'11"

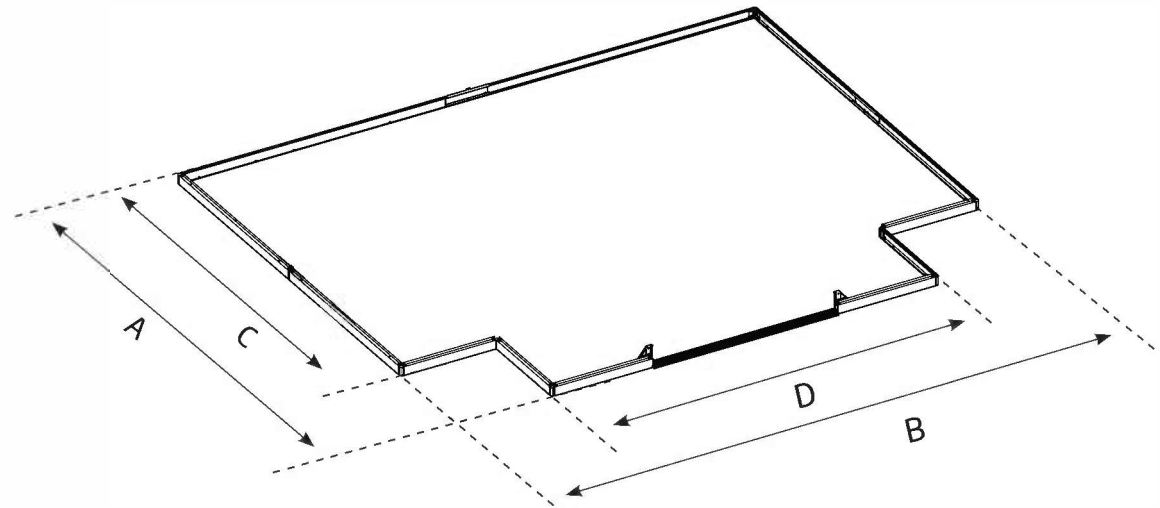

TOOLS & EQUIPMENT

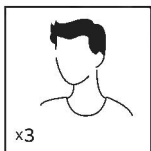

x3

3 people needed



Work gloves

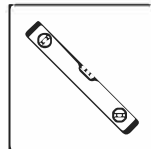

Spirit Level

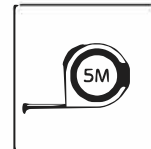

Tape measure



Phillips head Screwdriver

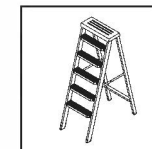

3 Ladders

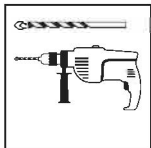

Electric Drill With Drill Bit 10 mm | 3/8"

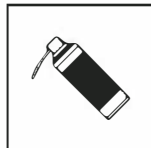

Lubricant Spray

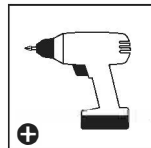

Cordless drill Phillips head



Wrench 10 mm | 3/8" 13 mm | 1/2"

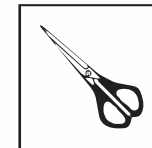

Scissors

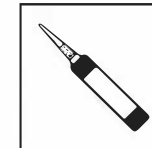

Silicone

SITE PREPARATION & FOUNDATION

A - PREPARE THE SITE

The product must be positioned and fixed on a flat level surface.

1 - Clear the site

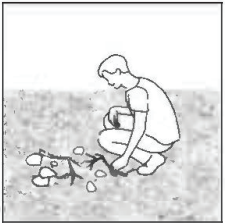

2 - Level the ground

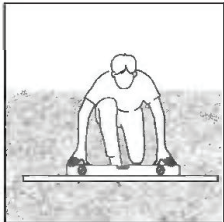
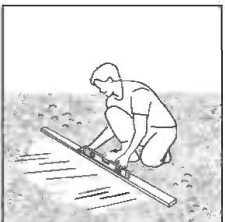

B - CHOOSE YOUR FOUNDATION TYPE

For a foundation, we recommend using three material types : Concrete / Pressure treated wood / wood deck / Paver blocks

Option 1: Solid foundation

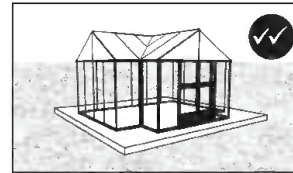
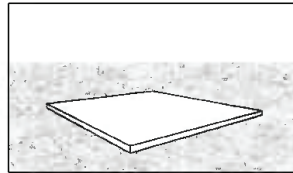

Option 2: Solid frame

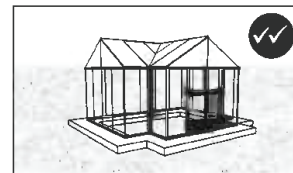
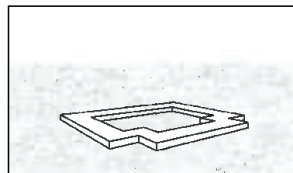

Option 3: Firm ground / grass

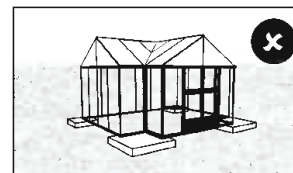
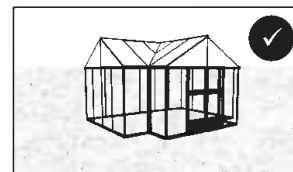

* The size of the product displayed is for illustration purposes only and may not reflect the size of your product.

C - ANCHOR TO FOUNDATION

3 options to anchoring the product to the foundation of your choice.

Internal anchoring

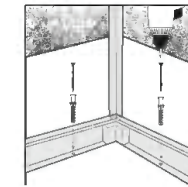

Supplied

1

Secure the product to the foundation of your choice using suitable screws & plugs or masonry anchors.

External anchoring

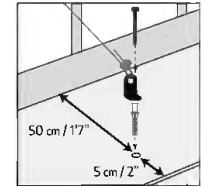

Supplied

2

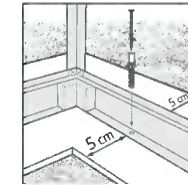

Supplied

Make sure you have at least 5 cm / 2" between the product base and the edges of your foundation - on all sides.

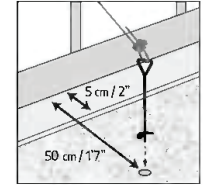

Not supplied

3

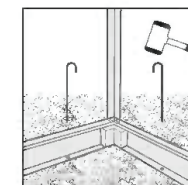

Not supplied

Secure the product to the ground surface using suitable long pegs.

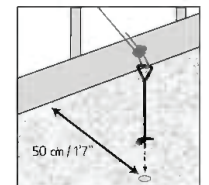

Not supplied

* Please consult with an expert regarding which fasteners are suitable for other surface types.

SAFETY ADVICE

- It is of utmost importance to assemble all of the parts according to the directions. Do not skip any steps.
- Always wear work gloves during panel sliding.
- Always wear shoes and safety goggles when working with extruded aluminium.
- If using a step ladder or power tools make sure that you follow the manufacturer's safety advice.
- Do not touch overhead power cables with the aluminium profiles.
- Do not attempt to assemble the product in windy or wet conditions.
- Do not climb or stand on the roof.
- Dispose of all plastic bags. Keep them out of reach of small children.
- Keep children away from the assembly area.
- Do not lean against or push the products during construction.
- Do not position your product in an area exposed to excessive winds.
- Do not attempt to assemble this product if you are tired, have taken drugs or alcohol or if you are prone to dizzy spells.
- Hot items such as recently used grills, blowtorches etc. must not be stored in the product.
- Make sure there are no hidden pipes or cables in the ground before anchoring to foundation.
- Keep roof and gutters clear of snow, dirt & leaves.
- In strong winds, all openings and the door should be closed. Greenhouse roofs should be cleared of snow in good time so that no dangerous snow load can occur.
- This product is designed to be used mainly as a greenhouse.
- **⚠ Make sure to anchor the product directly to a solid foundation to increase the product's stability and wind resistance in areas with severe weather conditions. Make sure that there are no obstructions between the assembly area and the final position of the product. The Anchoring kit is available for purchase separately.**

CARE & MAINTENANCE

- When your product needs to be cleaned, use a soft cloth and rinse with cold clean water.
- DO NOT use acetone, abrasive cleaners or other special detergents to clean the panels.
- Clean the product once assembly is complete.

BEFORE ASSEMBLY

- Selecting a site:
 - Choose your site carefully before beginning assembly.
 - Choose a sunny position away from overhanging trees.
 - The product must be positioned and fixed on a flat level surface.
- The product must be secured directly to a solid foundation.
- This is a multi-part assembly best achieved by two people. Allow at least half a day for the assembly process.
- Take all components & parts out of the packages. Sort the parts and check against the content parts list.
- Parts should be laid out close at hand. Keep all small parts (screws etc.) in a bowl so they do not get lost.
- Please note multi-sided profiles are used in this product. As a result some holes in the profiles are not used during assembly.
- Please review entire instructions before starting. Carry out the assembly steps in exact order.
- Please consult your local authorities if any permits are required prior to constructing the product.
- Please ensure you have sufficient side space for inserting the roof panels during the assembly process.

IMPORTANT!

- **Firmly connect the product to a level surface immediately after completion of the assembly.**
 - **Anchoring this product to the ground is essential to its stability and rigidity. It is required to complete this stage in order for your warranty to be valid.**
 - **During assembly use a soft surface below the parts to avoid scratches and damages.**
 - **We recommend checking for restrictions or covenants for building this product in your area.**
- In addition we advise to check if you need to submit any forms or if any permit is required prior to building the product.

DURING ASSEMBLY

During assembly, you will encounter different icons for different products. Please see below for more information:

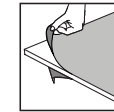

Make sure you remove covering plastic film from both sides of the panel.

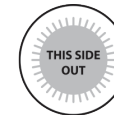

All panels with the stamped words "THIS SIDE OUT" must be facing out to create full UV protection. Remove plastic sticker as panels are locked in place.



This icon indicates that the installer should be inside the product.



This icon indicates that the installer should be outside the product.

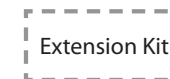

Steps marked with dashed outlines refer to Extensions only. Some of the steps are irrelevant for an assembly of a single product. When assembling a single or an extended product, some parts may be surplus.

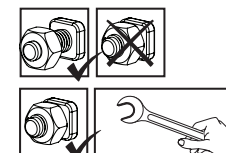

These 2 icons below indicate if screw's tightening is required or not. Temporary tightening of a few screws may be needed to prevent a profile from sliding out. Tighten all screws once assembly is completed.















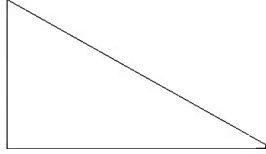

IMPORTANT ASSEMBLY STEPS





When encountering this information icon during assembly, please refer the relevant assembly step for important additional comments.

- Step 4:** Decide on the door's location before assembly. Door can be installed in one of the indicated options.
- Steps 16+21:** Make sure that the 4 holes of profile #9923 are in the upper part, as described in the close-up drawing (!).
- Steps 50,51,53:** Make sure that all the profiles are extended equally as shown in the close-up drawing.
- Steps 55+59:** All panels with the stamped words "THIS SIDE OUT" must be facing out to create full UV protection. Remove plastic sticker as panels are locked in place.
- Step 58:** Please use dry cloth to wipe the panel prior to attaching the sealing tape to the panels' edges.
- Steps 62+63:** Please repeat steps 59+61.
- Step 67:** Before tightening the screws (**Drawing a**) make sure that all the profiles 9906 are leveled.
- Step 74:** Prior to fitting the Automatic Vent Opener, the power tube has to be cooled by placing it in a refrigerator for approximately 30 minutes.
- Step 75:** In order to close the window after fitting the Automatic Vent opener, the piston must be rotated in the direction as show in **Drawing C**.
- Step 76:** It is recommended to use a carton or other soft material under the lowered corner in order to avoid scratches and peeling of paint.
- Step 81:** If necessary, you can rotate the cylinder tab. See Figures **a + b**.
- Step 88:** Make sure the base is square by measuring the diagonals and level by using a spirit level. Anchoring this product to the ground is essential to its stability and rigidity. It is required to complete this stage in order for your warranty to be valid.
- Steps 88+94:** The supplied screws and fasteners are suitable for concrete floor only. If the product is fixed to a different type of floor, consult with an expert regarding which fasteners are suitable for other surface types.
- Step 96:** **Optional for expected heavy snow load locations –** For additional reinforcement, connect a wooden post in the middle of the product (the wooden post and screws are not supplied). The wooden post must be prepared according to the dimensions in **Drawing a**, then anchored to a solid surface with supplied masonry anchors #9227.





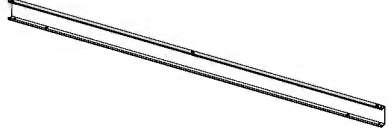
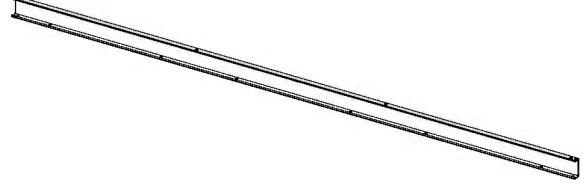

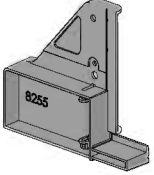
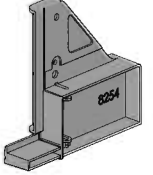
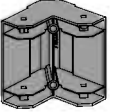
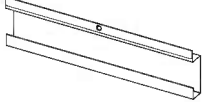
CONTENTS

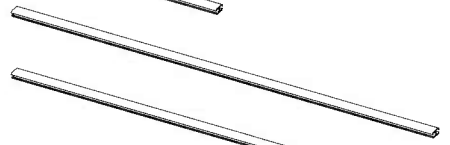
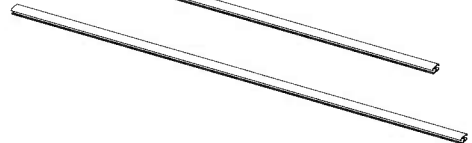
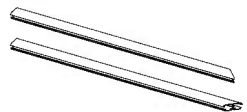

Item		Qty.
9876		16
9924		4
9879		8
9972		2
9880		2
9877		6
9878		6

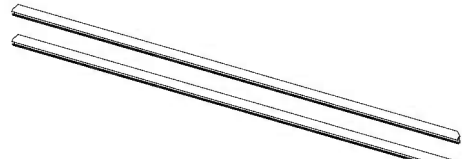
Item		Qty.
9881		2
9882		2
9883		2
9884		2
7945		2
8702		4
1171		50 (+2)
7914		4

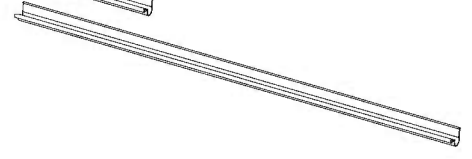
Item		Qty.
9918		4
9919		2
9916		4
9917		2
9886		1
8255		1
8254		1
7602		8
7601		3

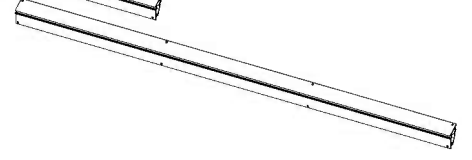
CONTENTS

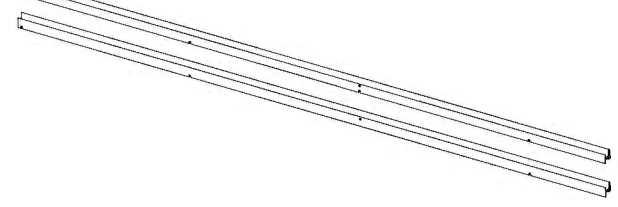

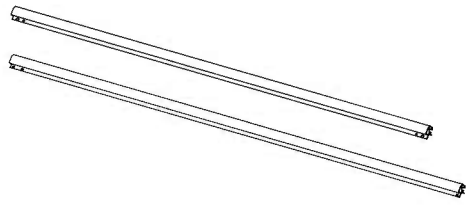
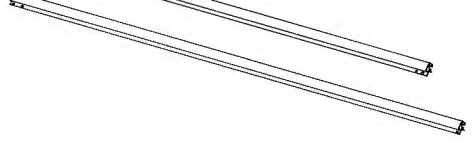
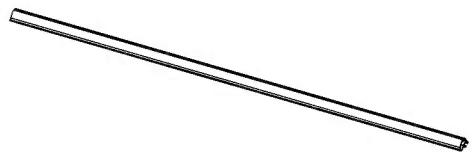
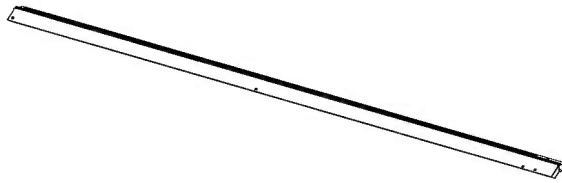
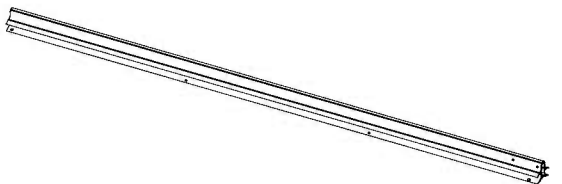
Item		Qty.
9902		3
9897		5
7892		11
9900		2
9901		2
9898		2
9899		2
9908		4
9907		2
9910		4
9909		2

Item		Qty.
1167		3
9904		2
1206		1
9896		6
9923		6
9905		2
9903		2
9906		3

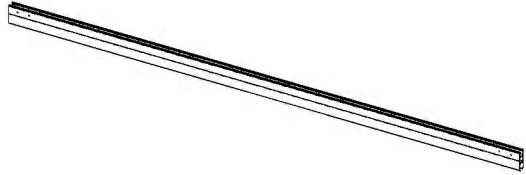
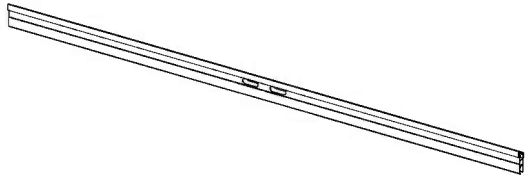
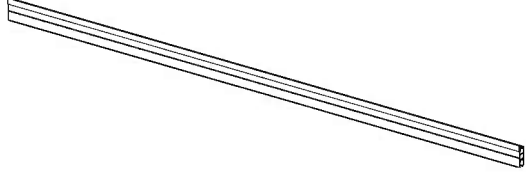
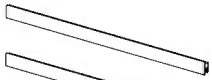
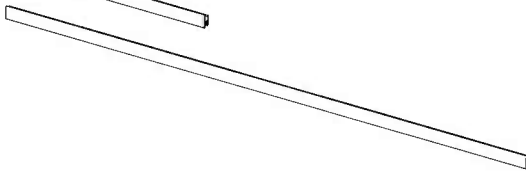

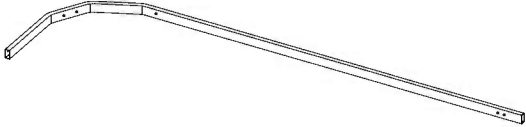
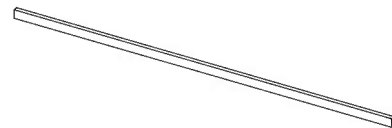

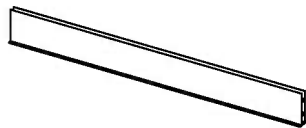
CONTENTS

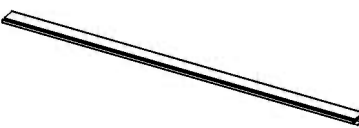
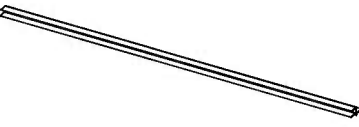
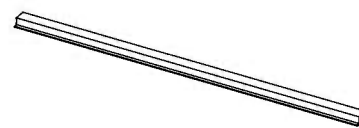
Item		Qty.
9888		1
9889		1
9887		2
9969		2
7884		2

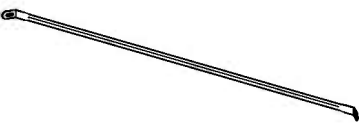

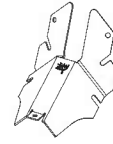

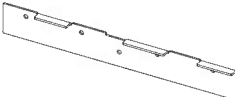
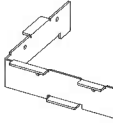
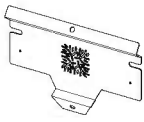
1512 / 1173		6
1513 / 1174		3

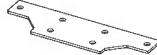



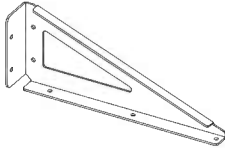
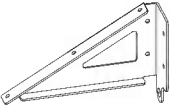

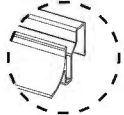
Item		Qty.
9890		4
9891		4
9895		2
9894		2
7878		4

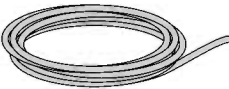

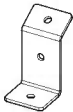



9892		4
9875		3



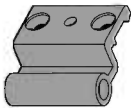
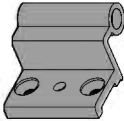



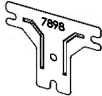

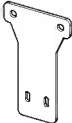
Item		Qty.
1170		2
1168		6
9009		1
9964		1
9965		2
9843		1
1169		3
1205		4

CONTENTS

Item		Qty.
9960		3
9961		1
1326		40
1325	 	6
7332		4
7333		8
8959		4

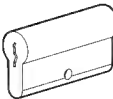
Item		Qty.
9967		1
9968		8
7894		5
7331		8
8274		3
9227		23
1257		1

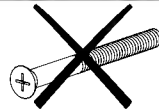
Item		Qty.
7923		12
7919		6
7918		6
7920		6
7921		6
7924		24
7922		6
7898		4
964		2
1204		2

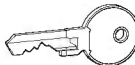
Item		Qty.
7994		2
7995		1
9312		2
7912		1
7913		1
9301		1
7958		1
	 *DO NOT USE	
7993		1
8039		1

CONTENTS

Item	Qty.	Item	Qty.	Item	Qty.	Item	Qty.
9707	2	7009	4 (+1)	7284	32 (+3)	4010	27 (+2)
7909	3	8293	1	8192	197 (+19)	4000	27 (+2)
7910	3	466	245 (+35)	7221	8	450	2
7908	3	4024	1	8077	6	8107	2
9831	2	425	2	7682	1	465	8
7911	1	433	27 (+2)	7442	60 (+6)	422	8
9830	1	5001	238 (+20)	9708	10 (+1)	421	8
		5000	19 (+5)	7445	46 (+4)		
				4008	27 (+8)		
				4045	40 (+9)		

*DO NOT USE

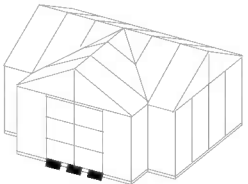

- 9886 1
- 8254 1
- 8255 1
- 450 2

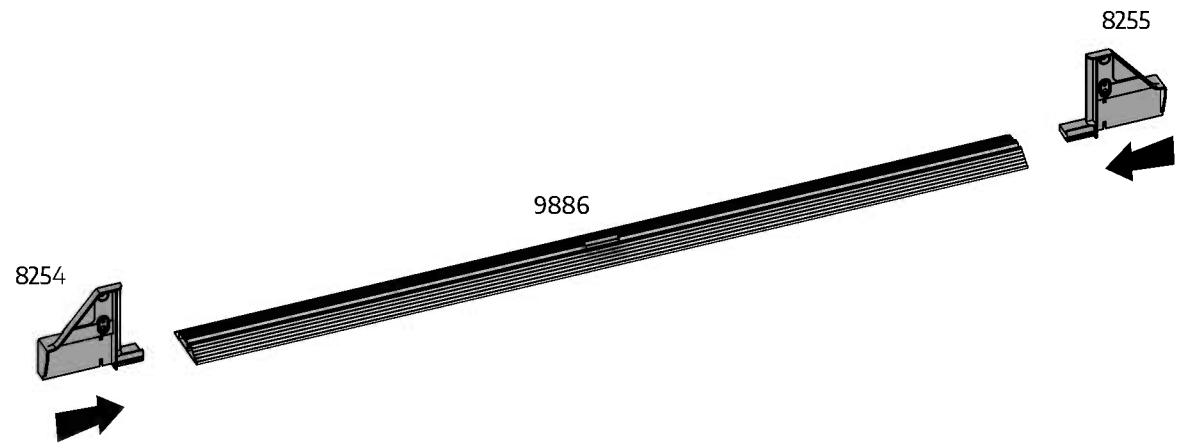
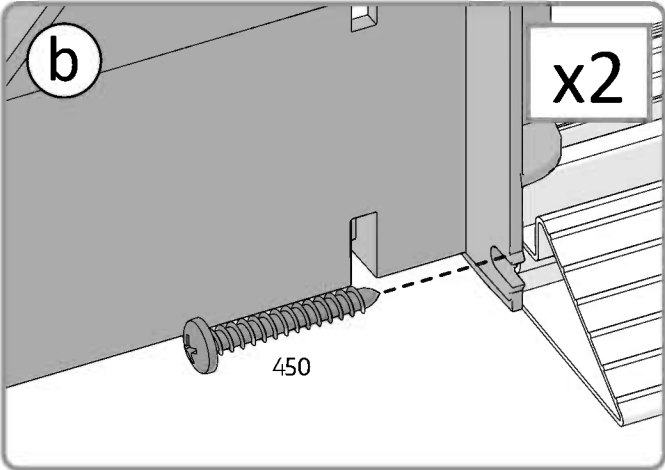
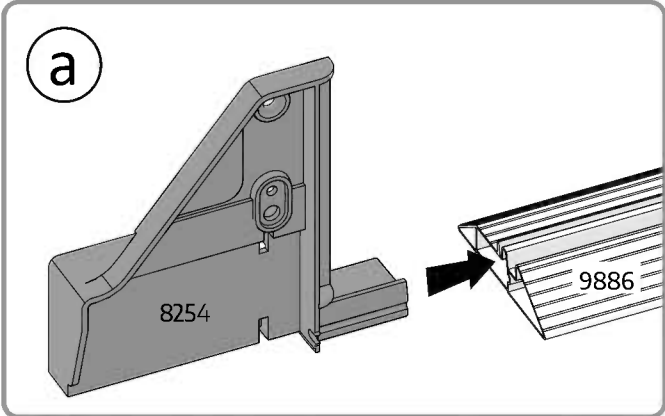

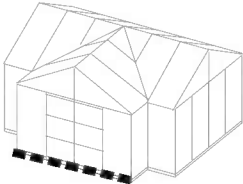

9919

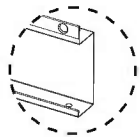

..... 2

7442



..... 4

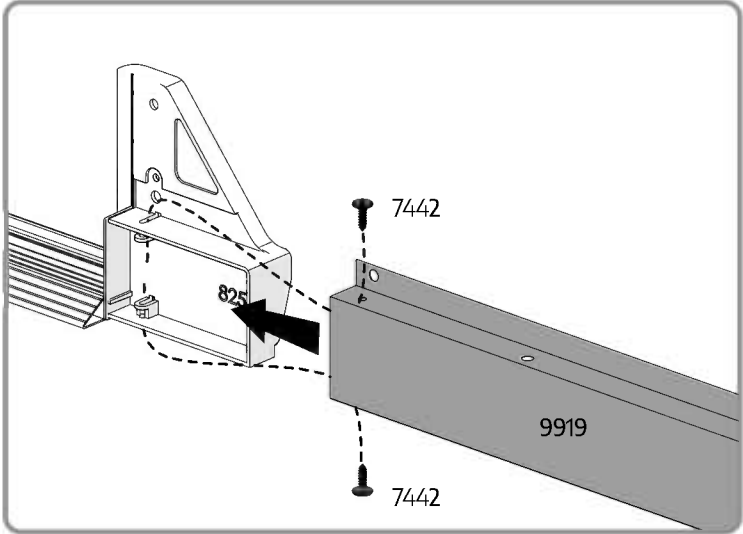
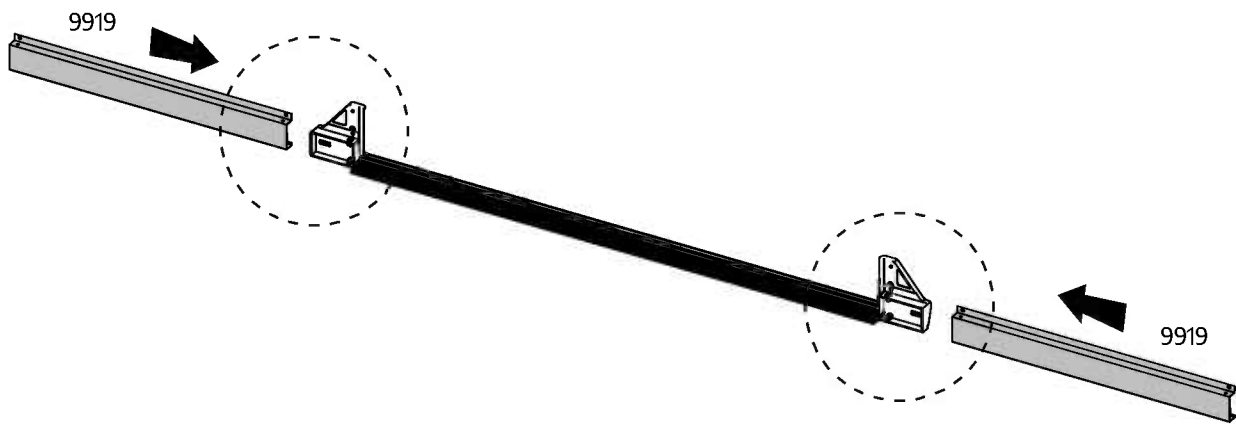

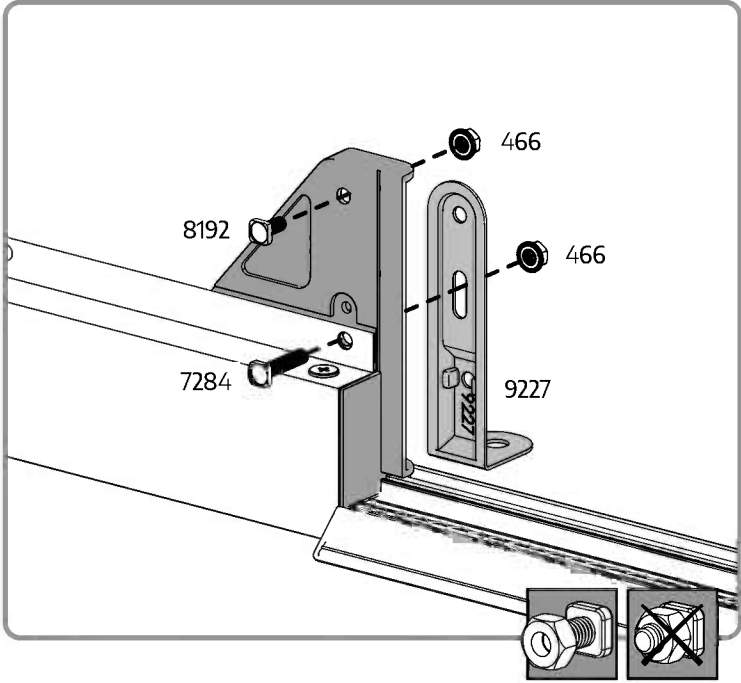
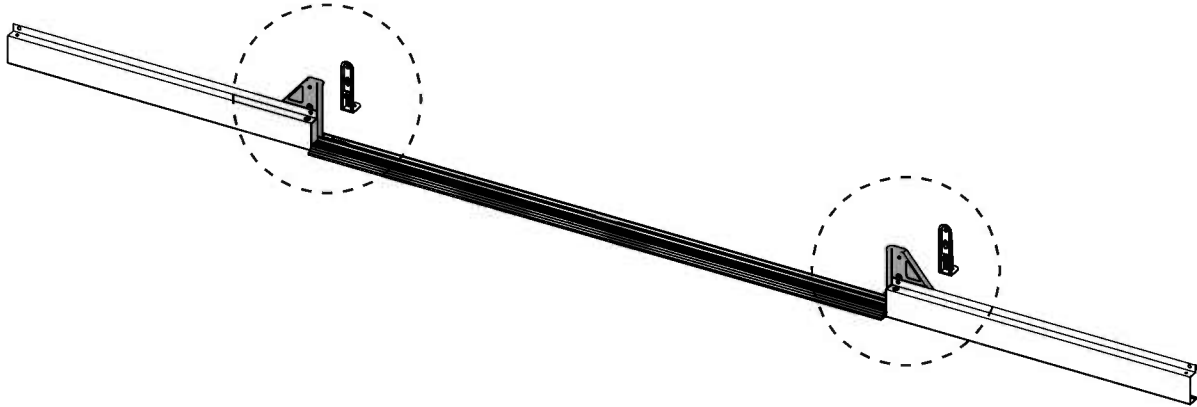
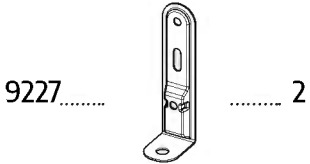
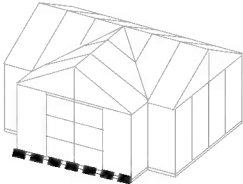

4



Decide on the door's location before assembly.
Door can be installed in one of the indicated options.

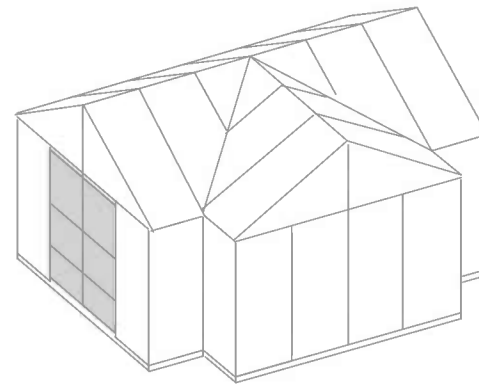
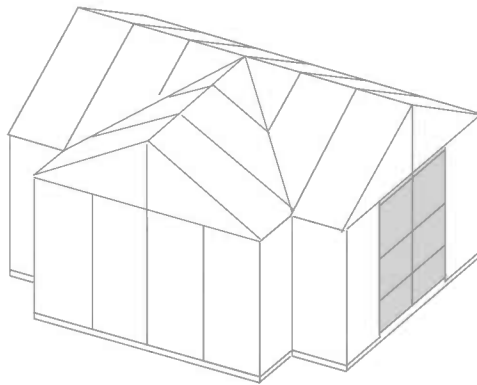
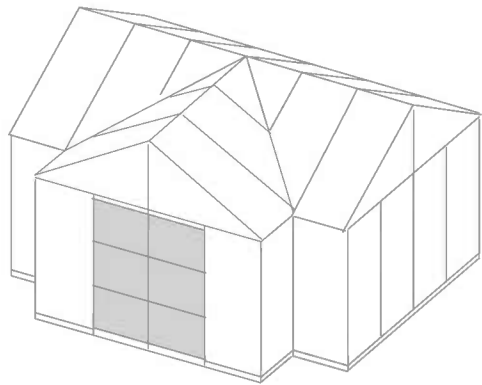
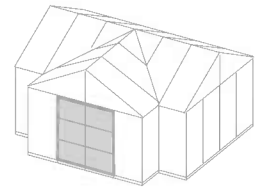

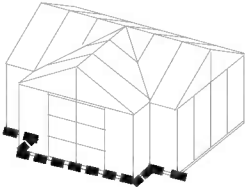

9918 4 7602 4 7442 16

7442

7602

7442

x2

9918

9918

9918

9918

9918

9918

+

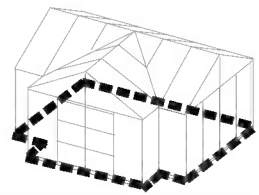

9916.....

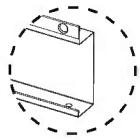

..... 4

9917.....

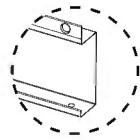

..... 2

7601.....

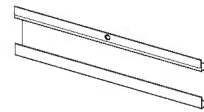

..... 3

7442.....



..... 24

(a)

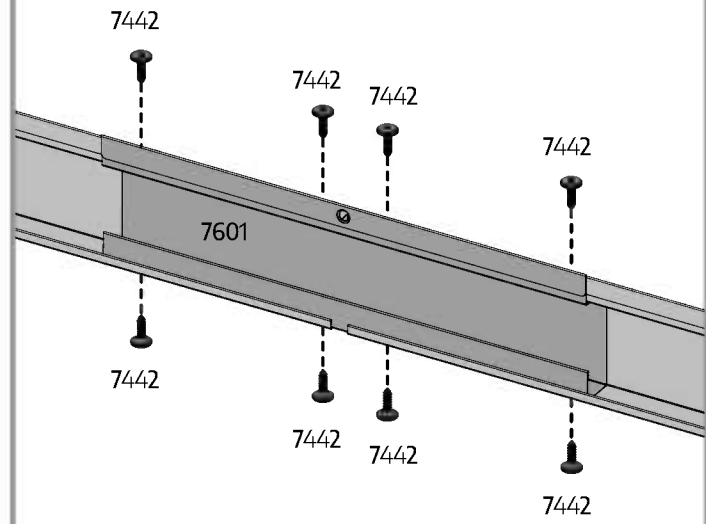

x3

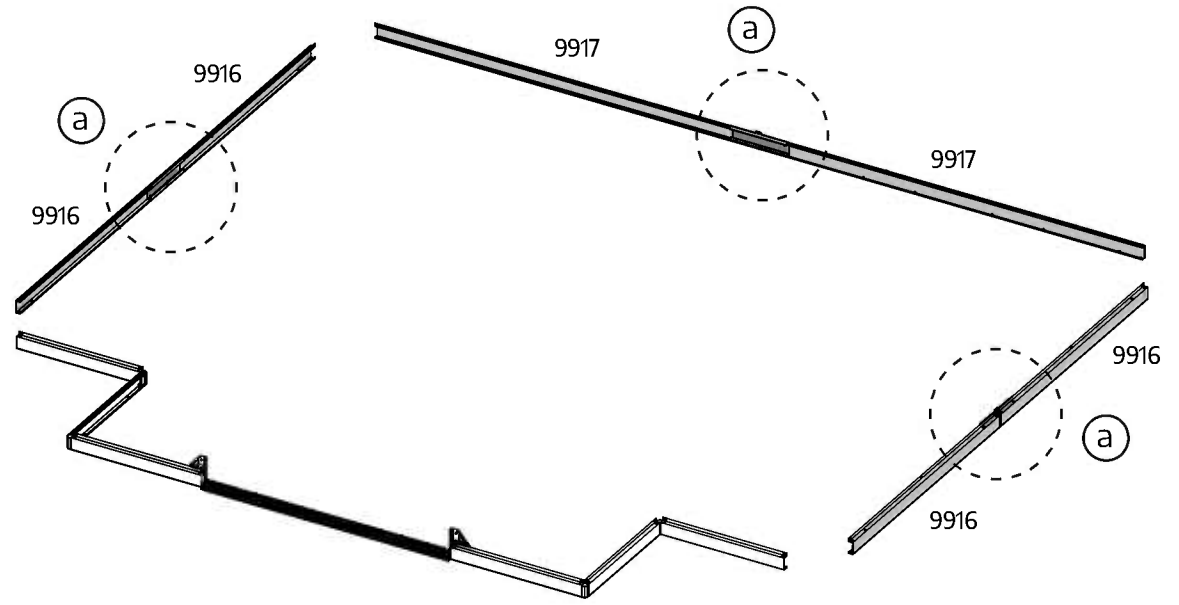
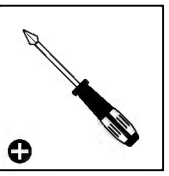
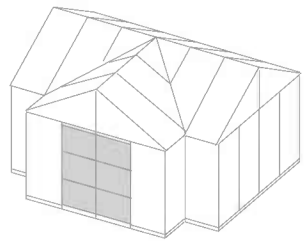

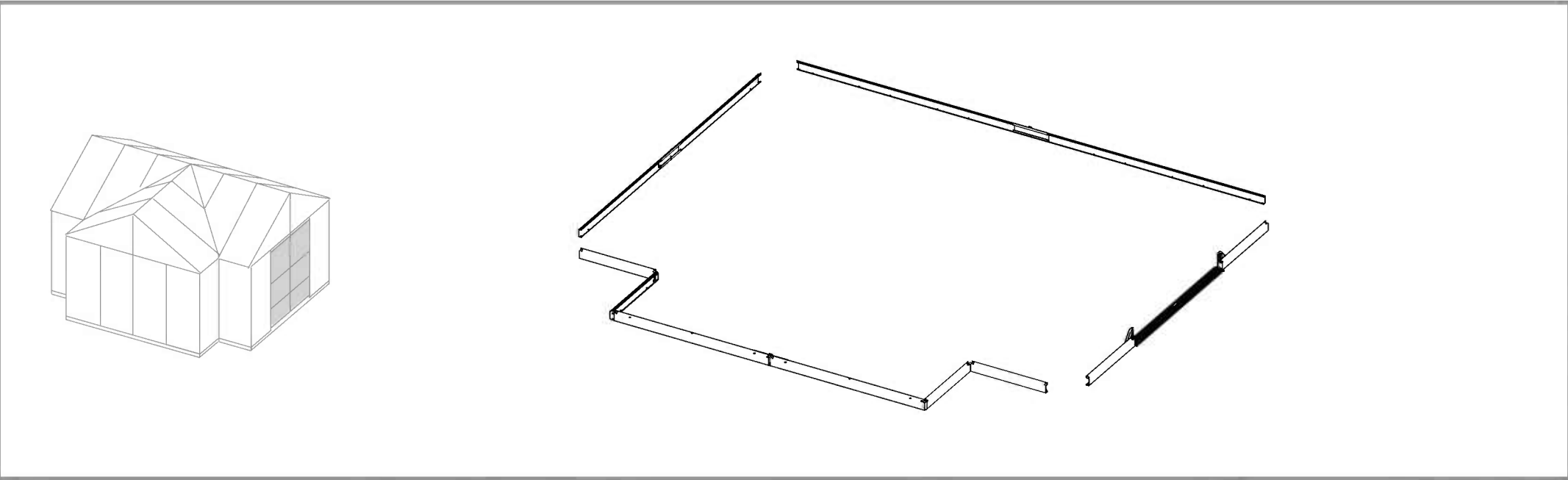
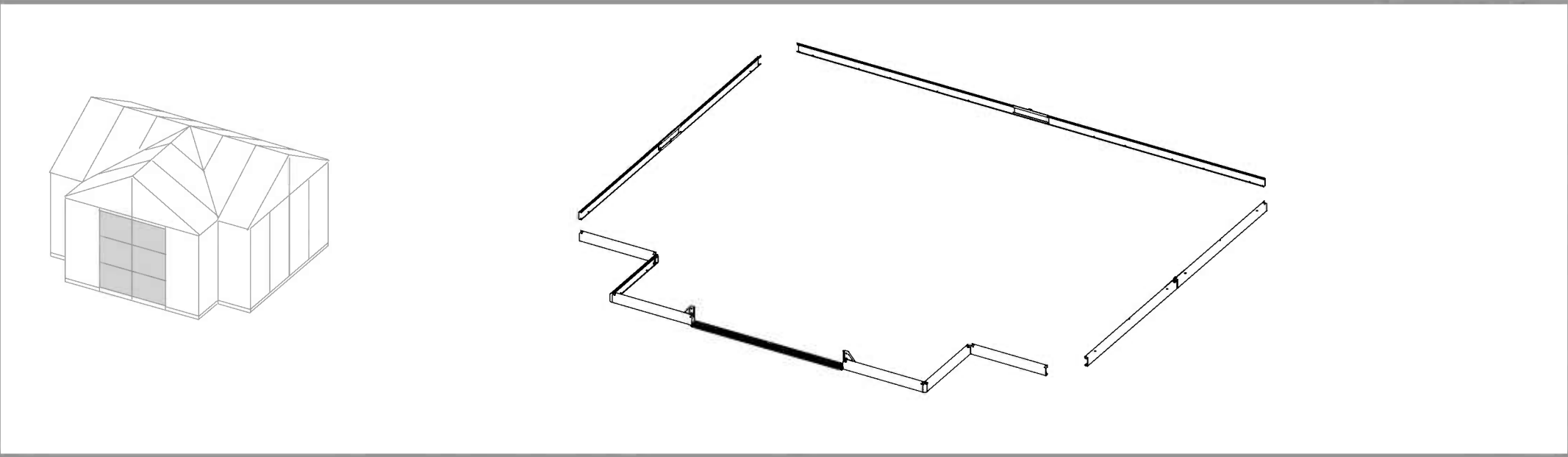
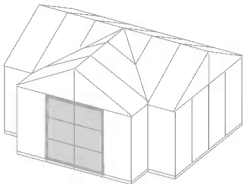

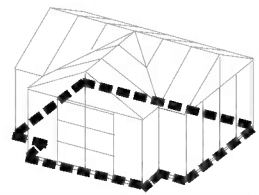



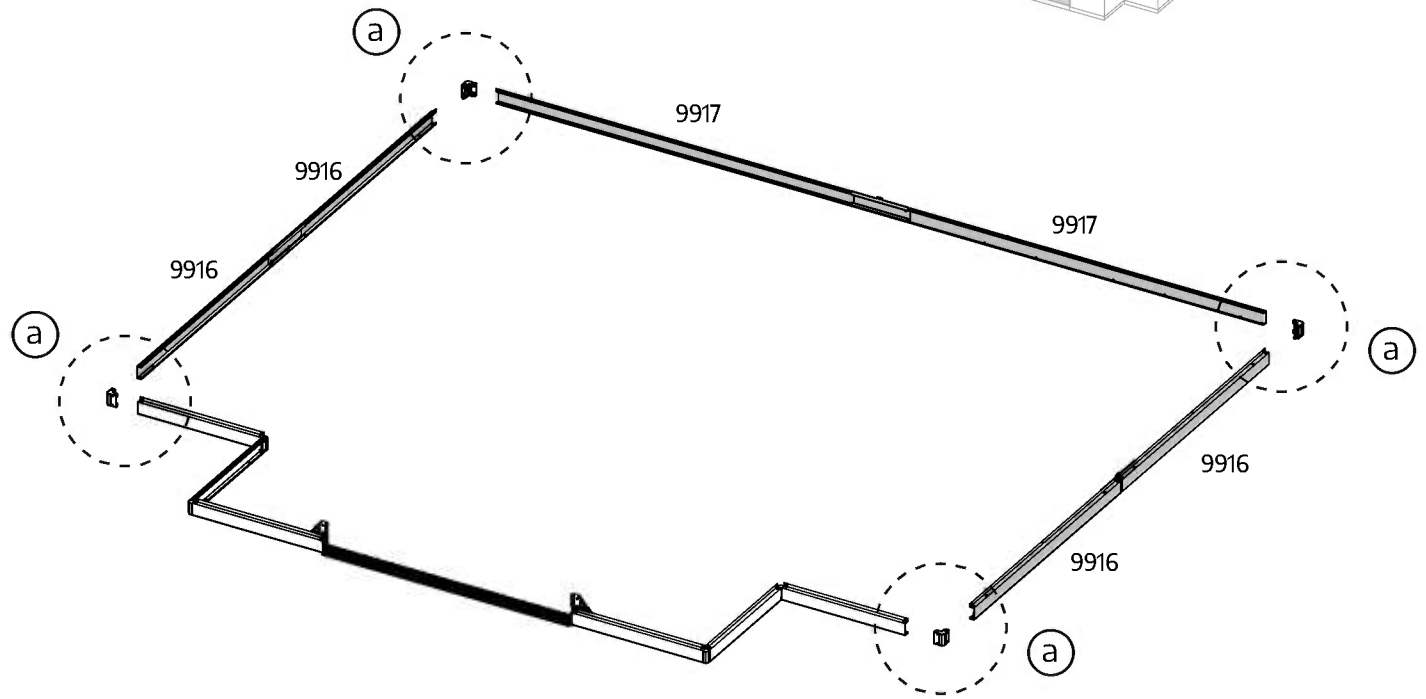
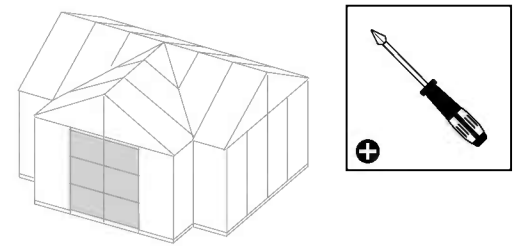
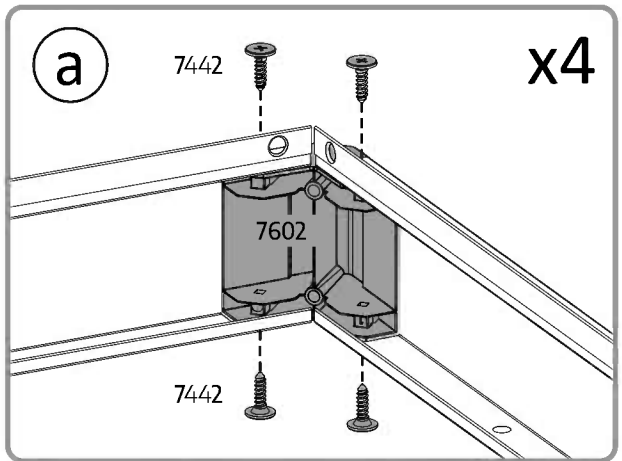

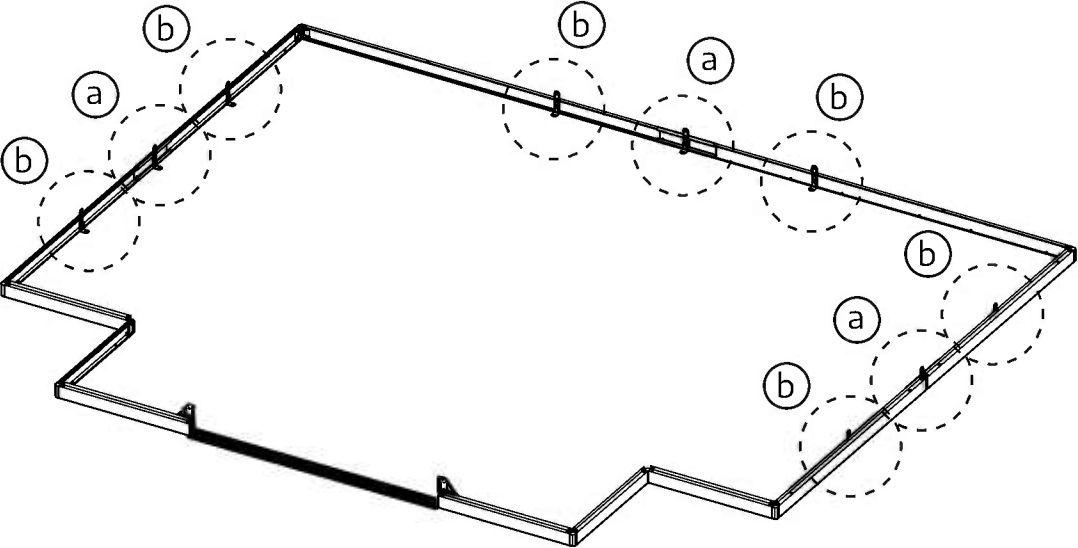
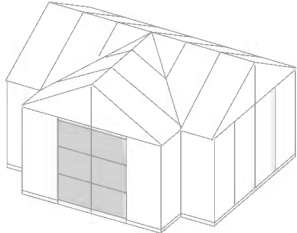
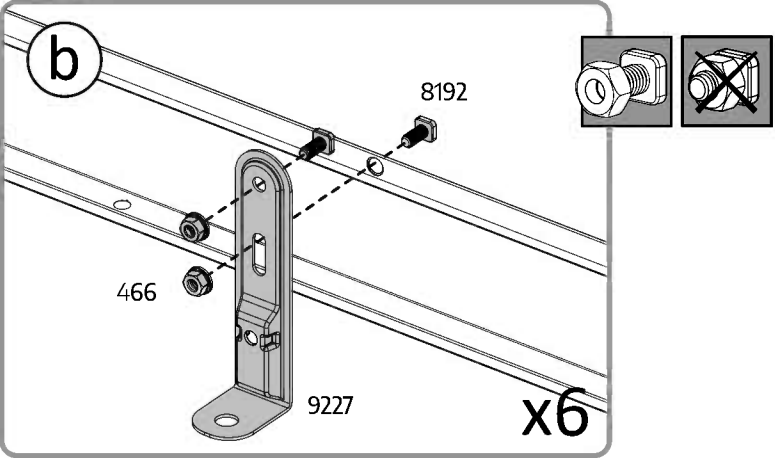
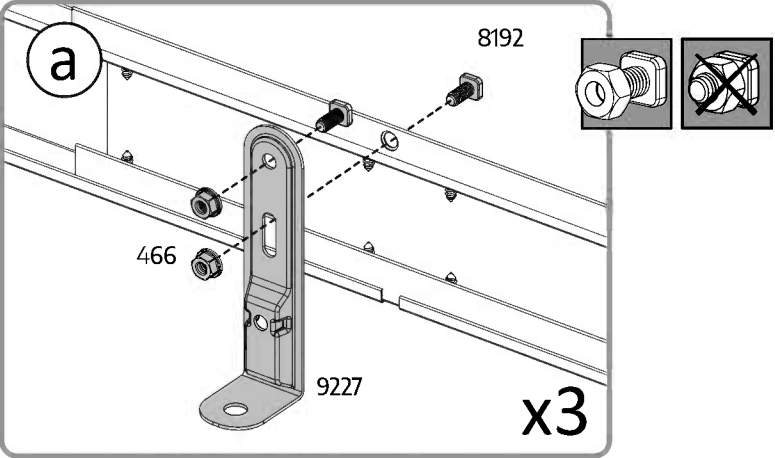
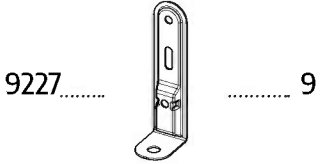
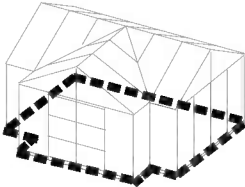
- 7602 4 7442 16
- 
- 

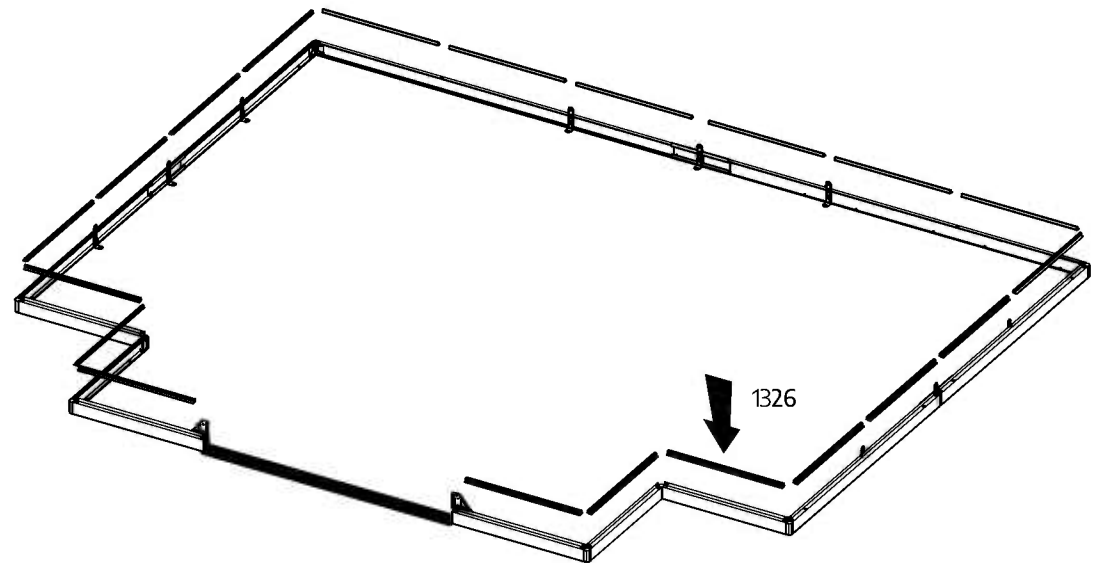
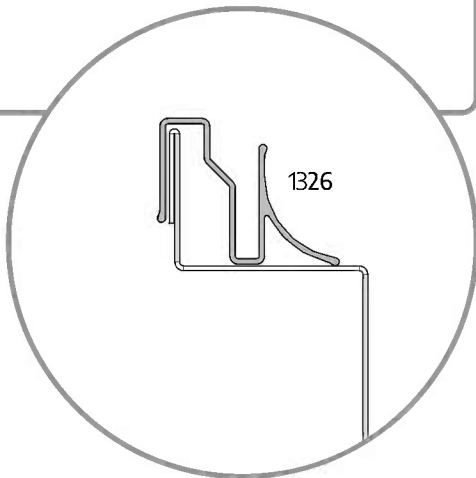
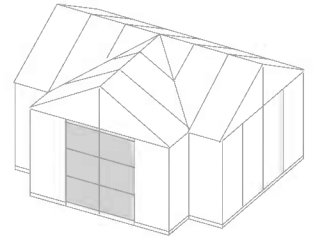
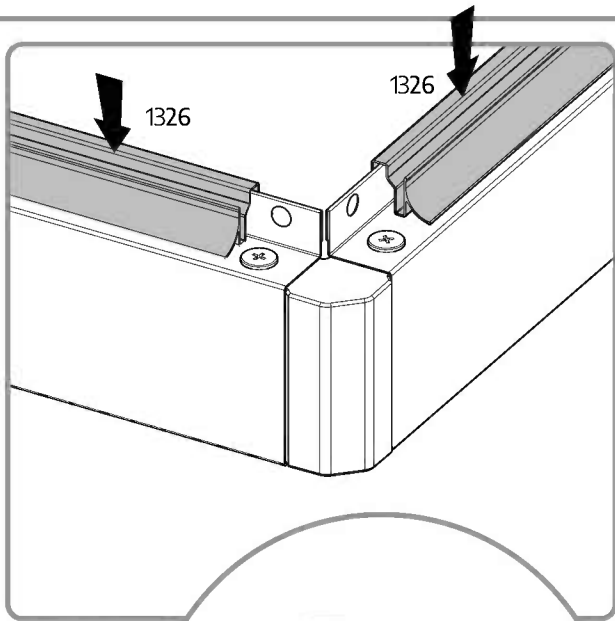
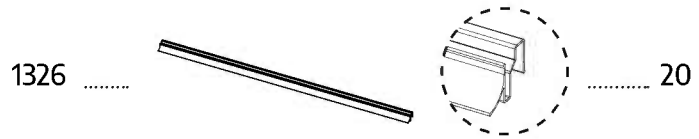
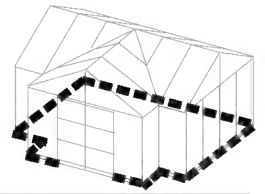

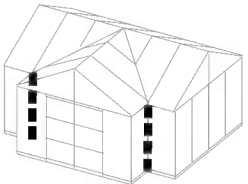

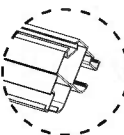

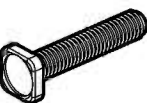

- 9905.....  2
- 9227.....  2
- 7284.....  12
- 8192.....  4
- 466.....  4

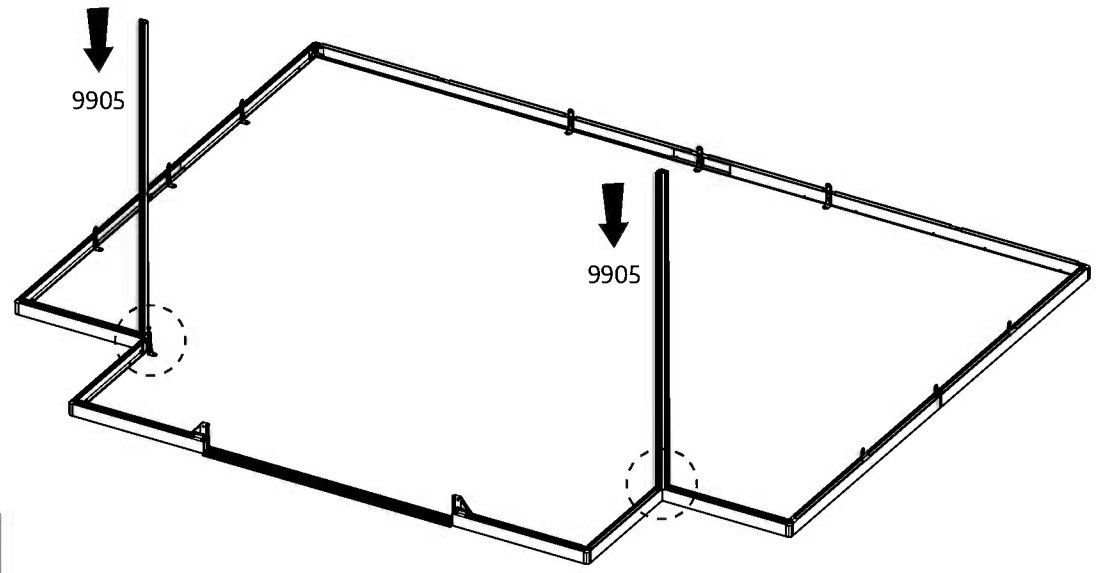
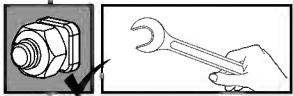
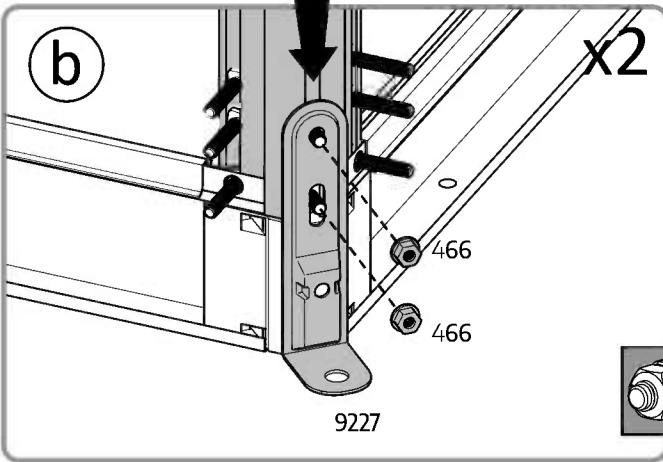
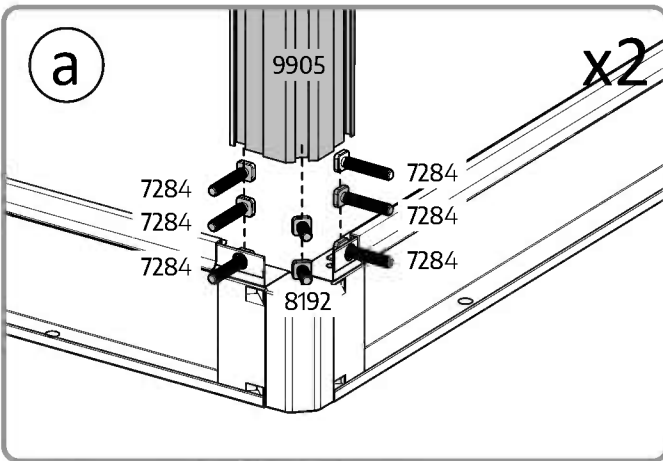

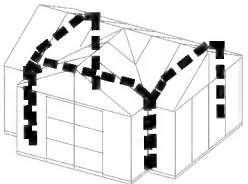

1512 / 1173 6 1513 / 1174 3 1168 6 4045 24

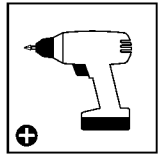
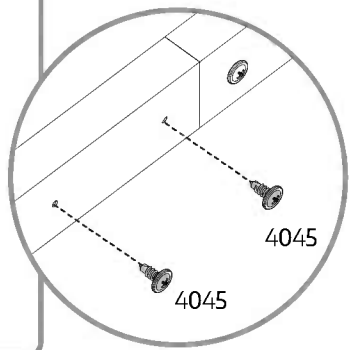
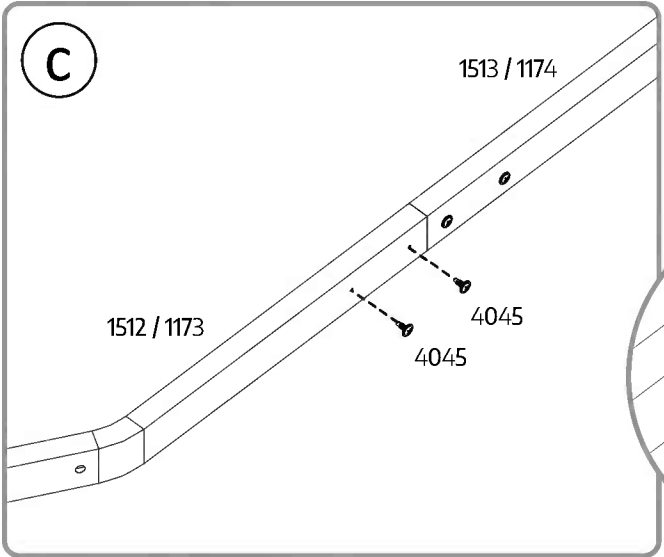
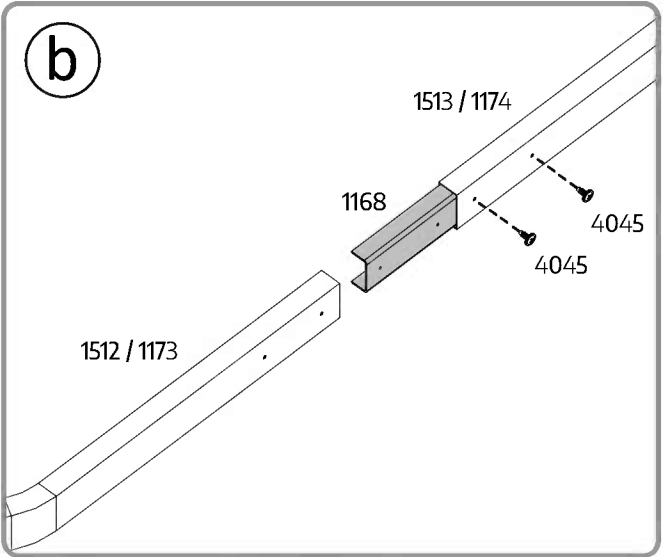
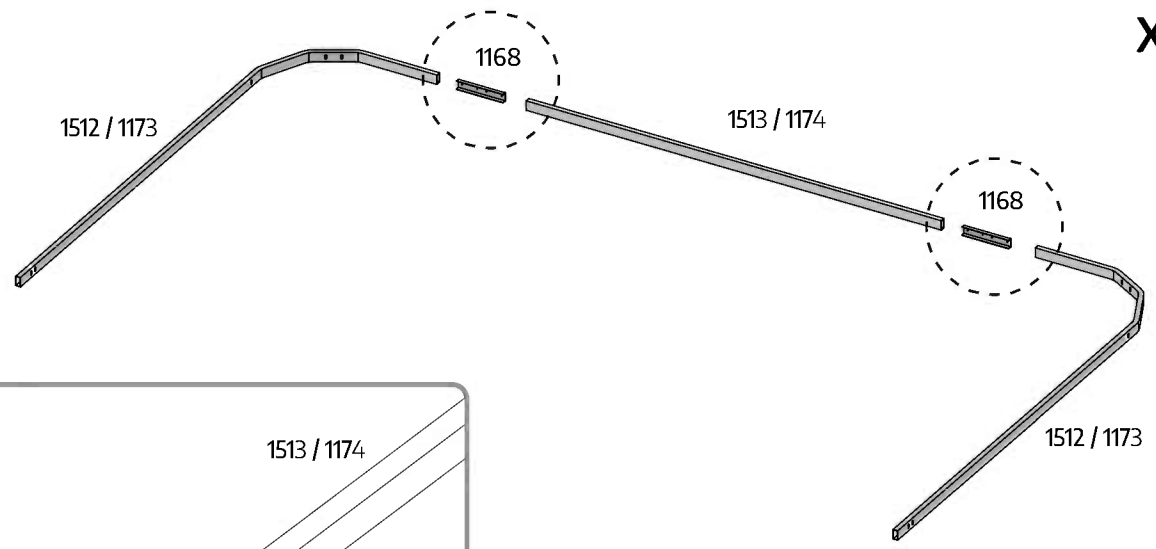
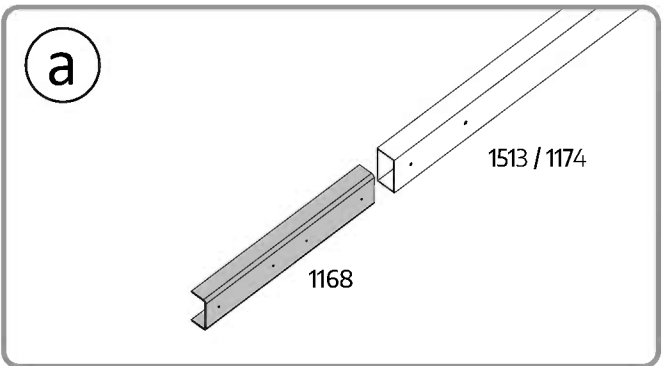

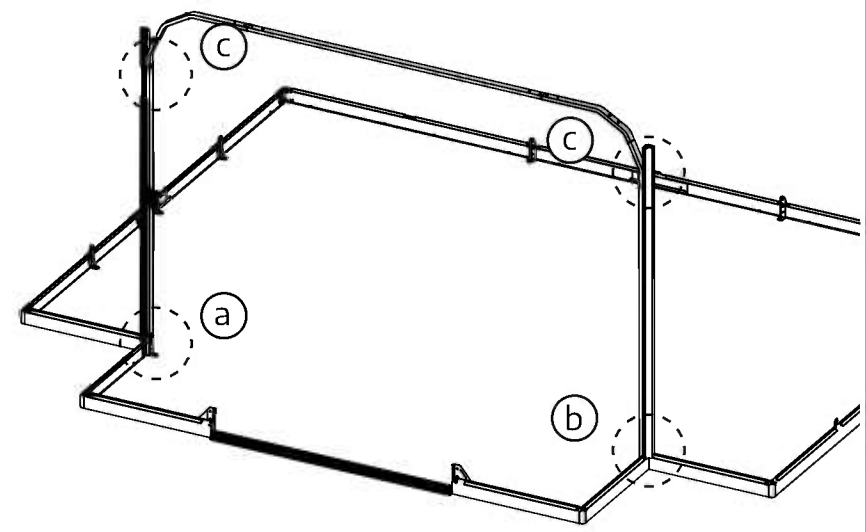
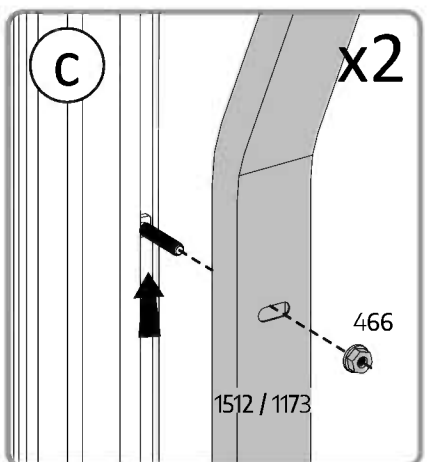
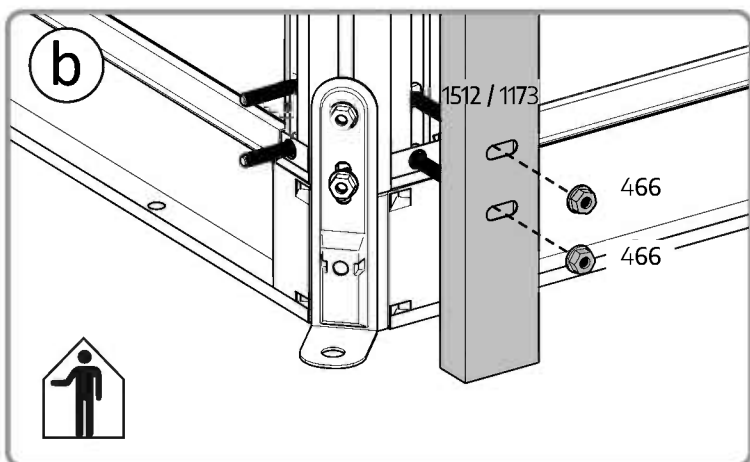
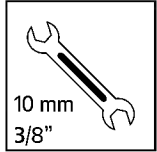
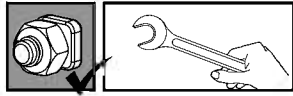
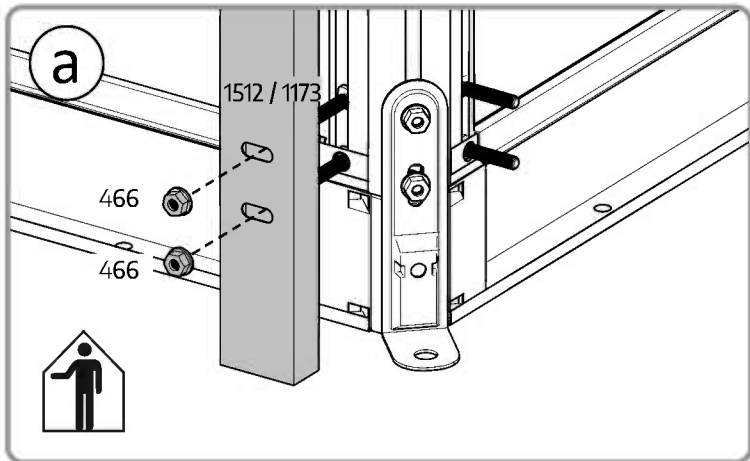
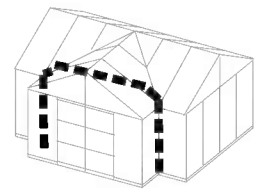

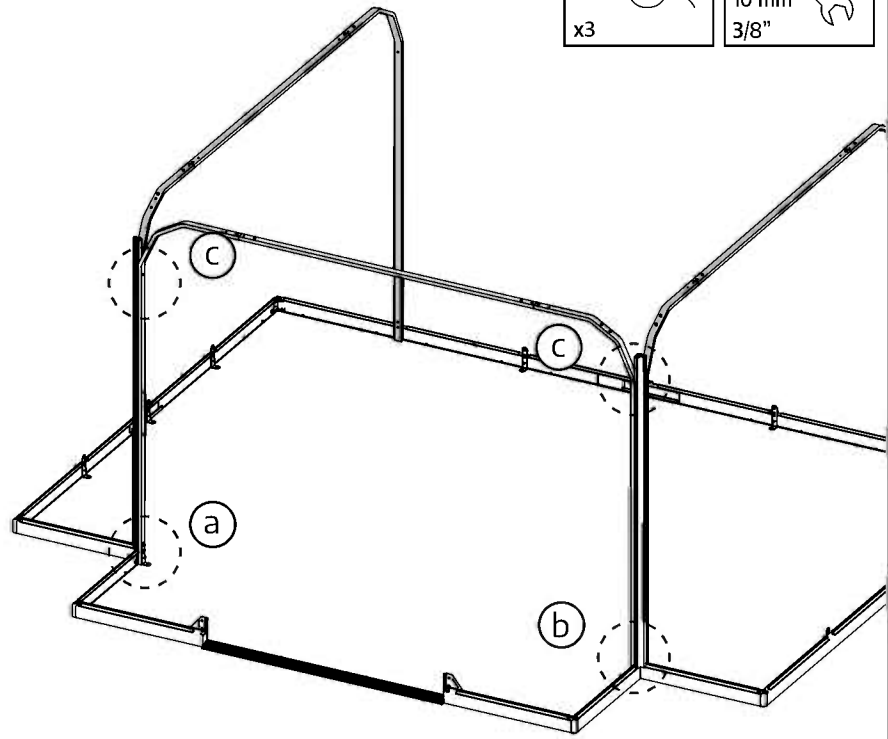
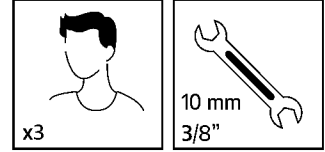
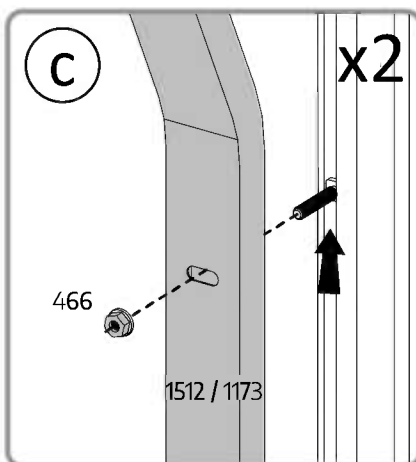
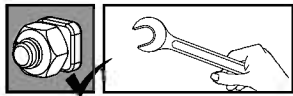
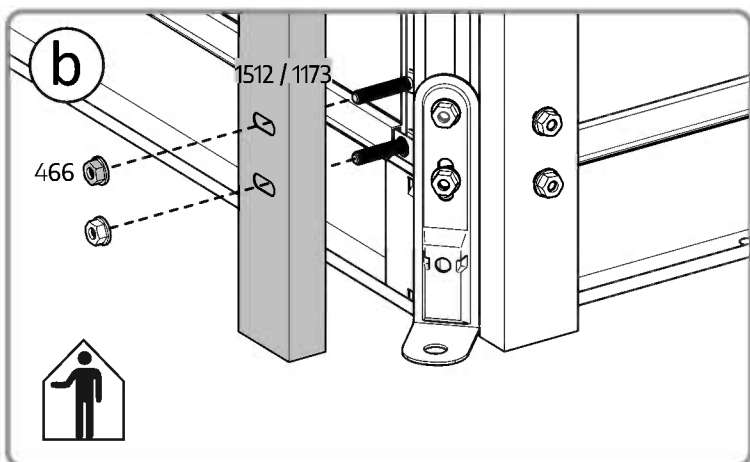
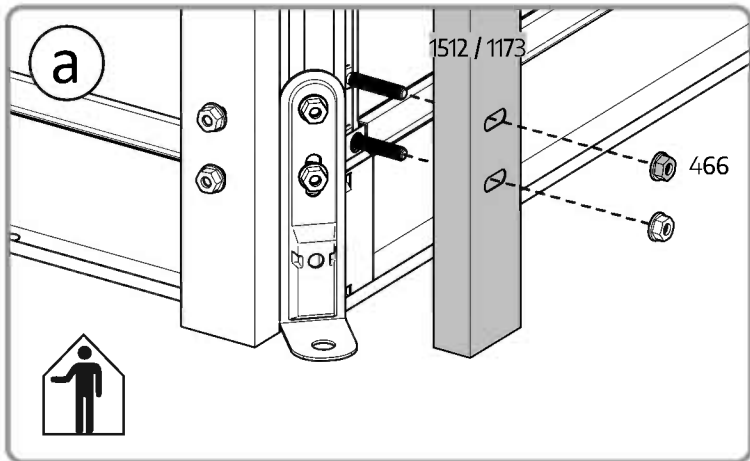
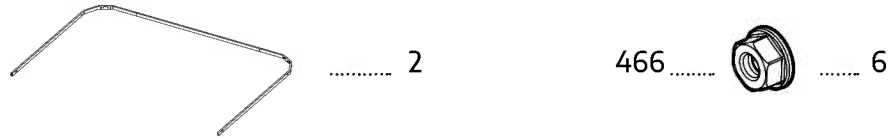
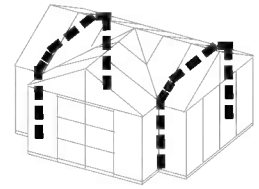

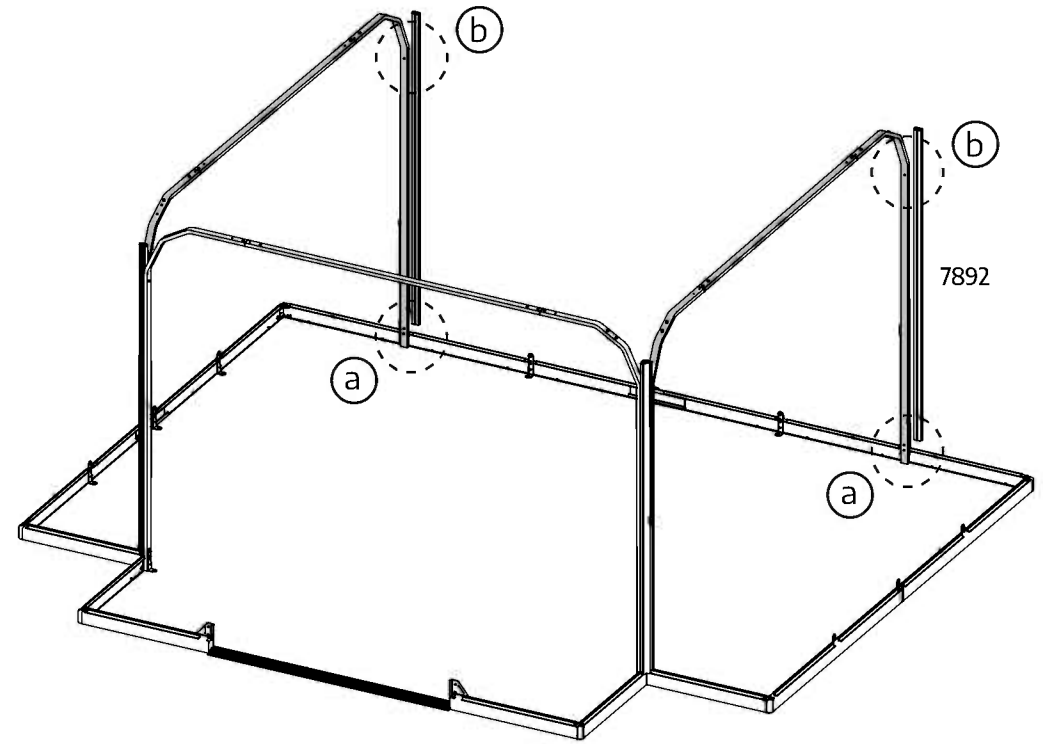
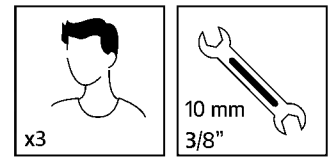
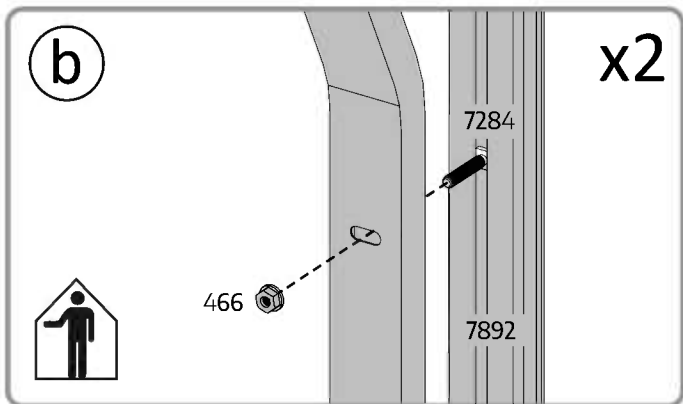
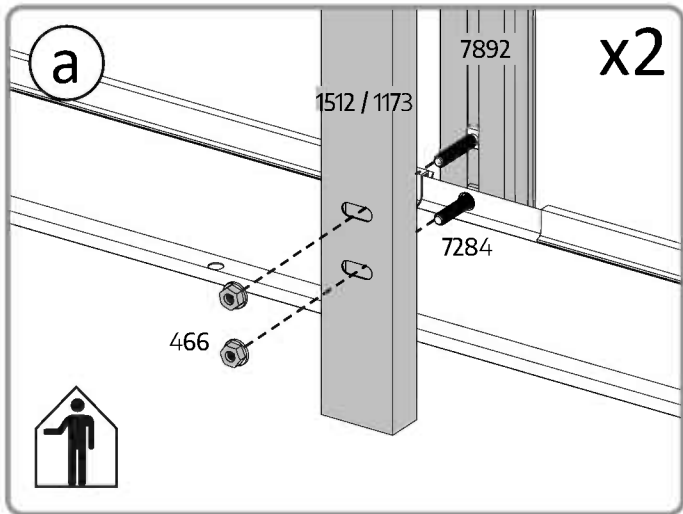
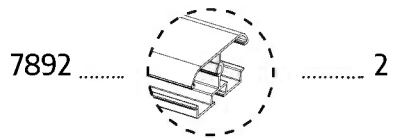
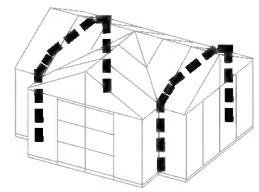



Make sure that the 4 holes of profile #9923 are in the upper part, as described in the close-up drawing (!).

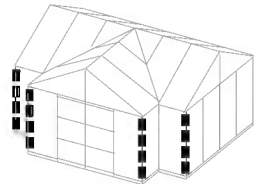

9923 4

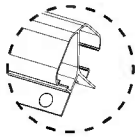

9227 4

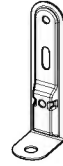

8192 8



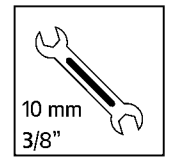
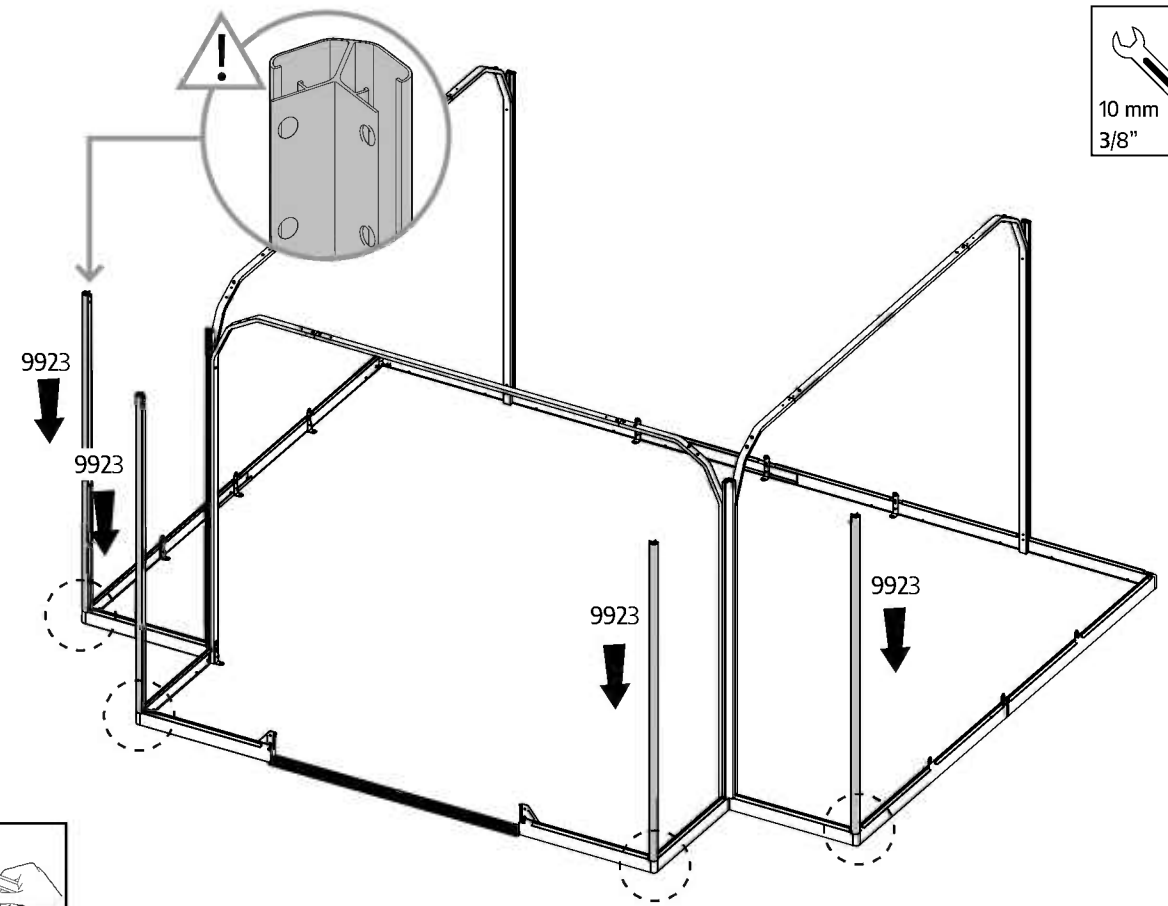
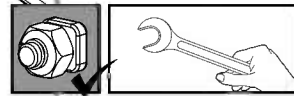
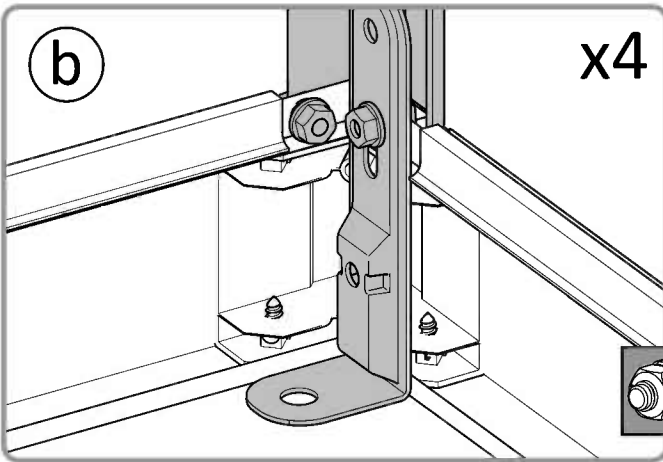
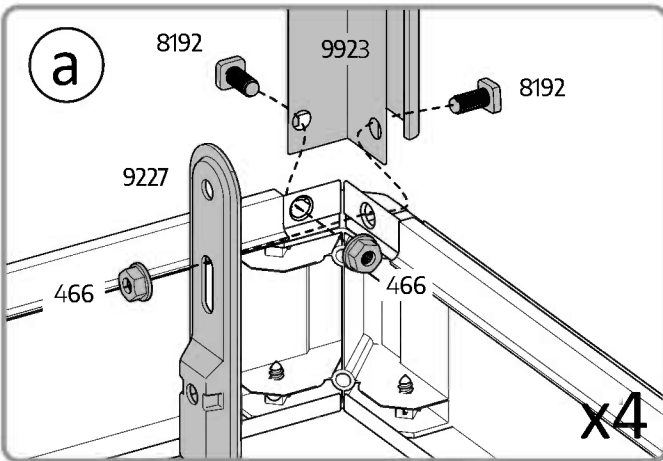

466 8

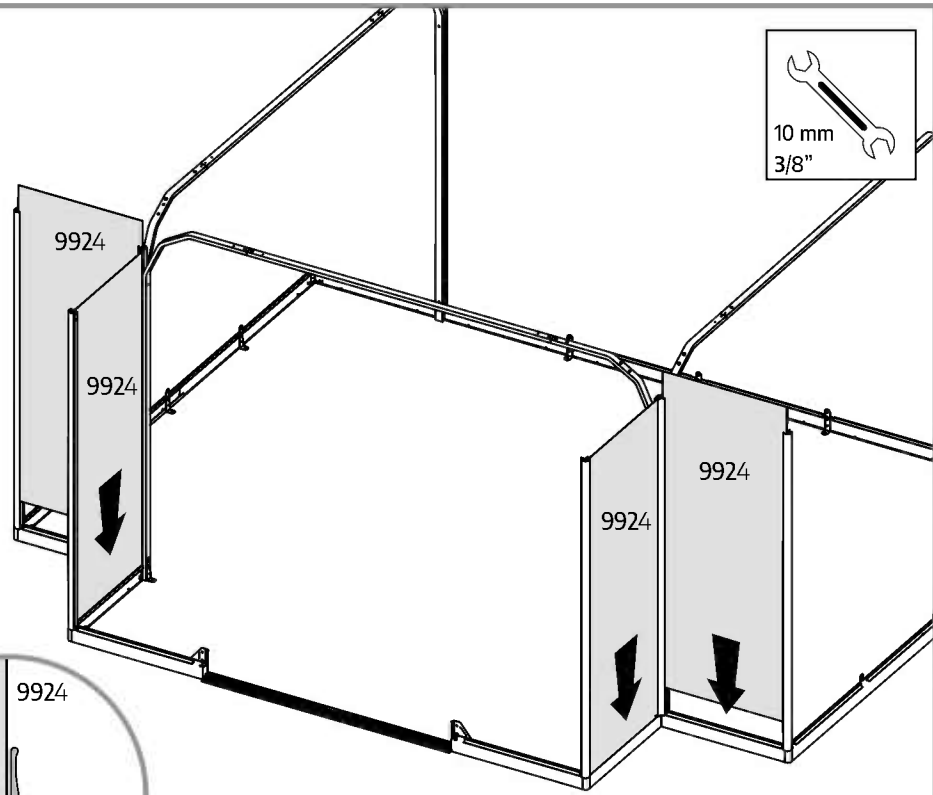
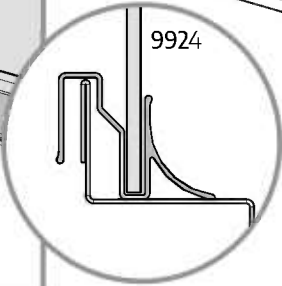
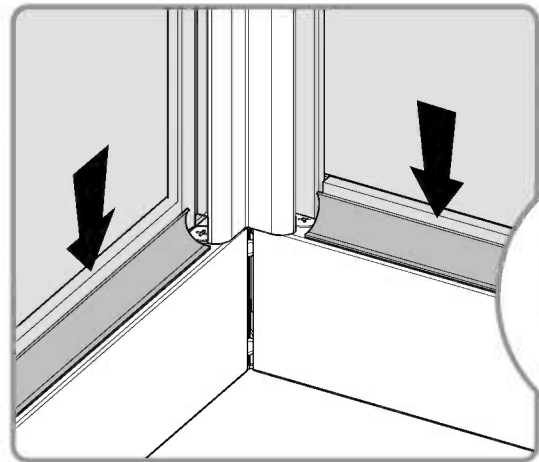
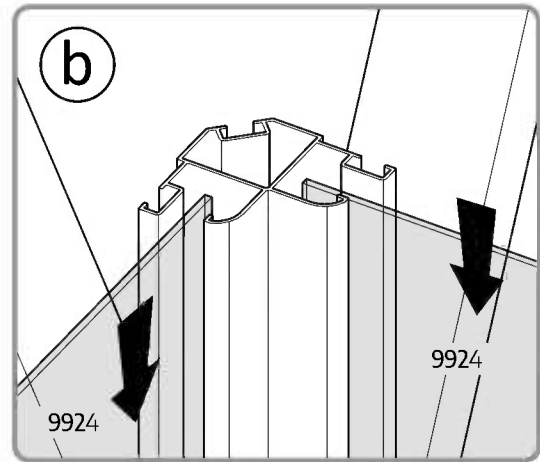
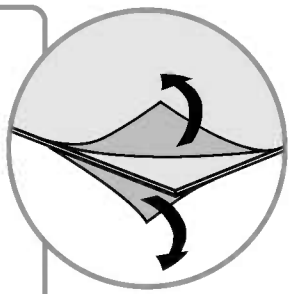
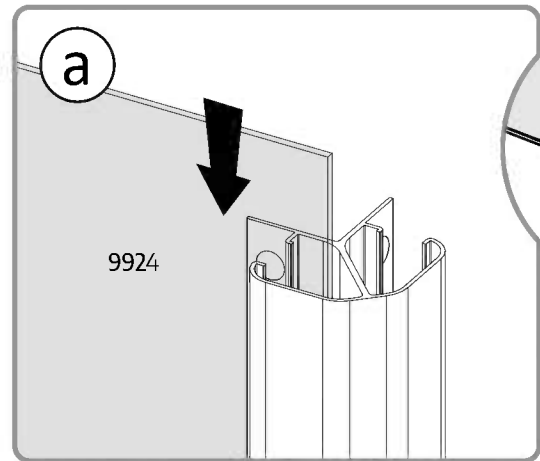
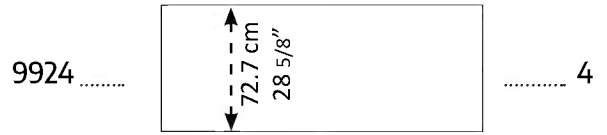
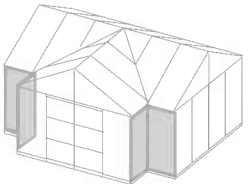

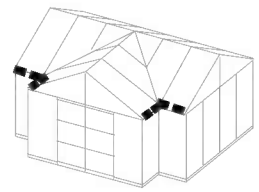



1326  4

8192  4

466  4

a

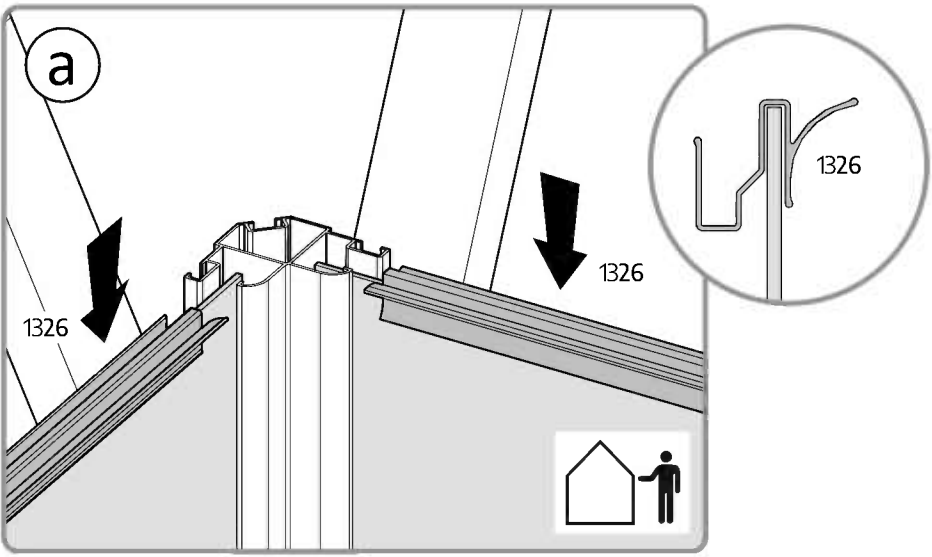

1326

1326

b

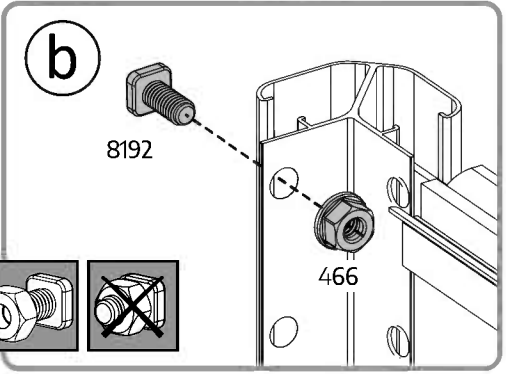

8192

466

c

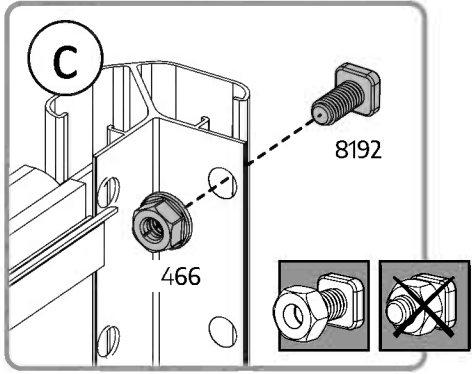

8192

466

a **b** **c**

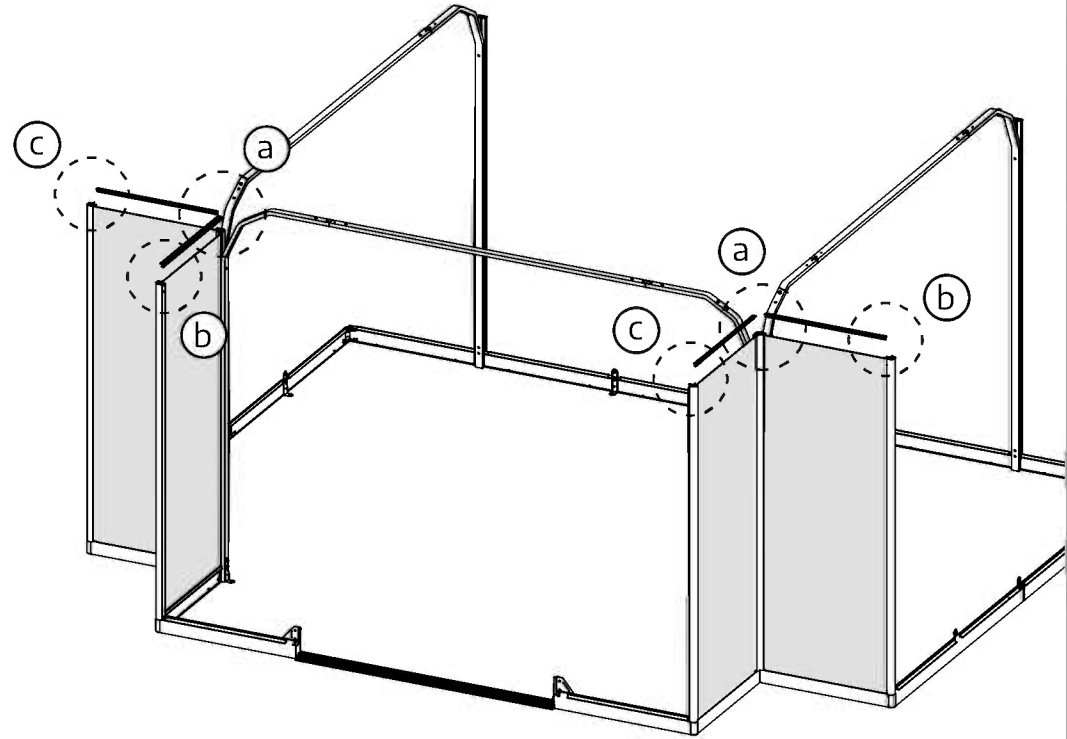

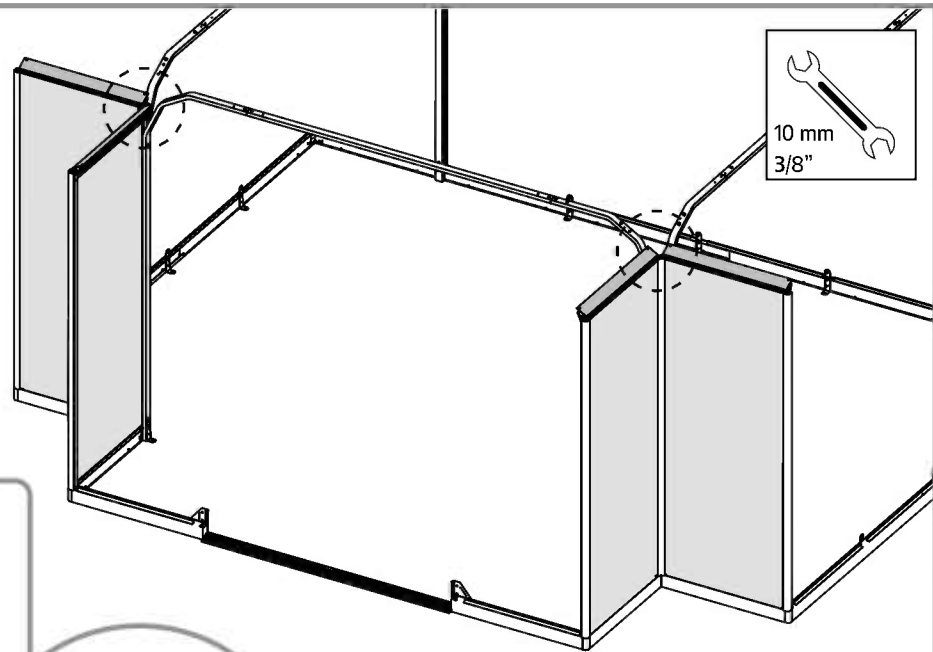
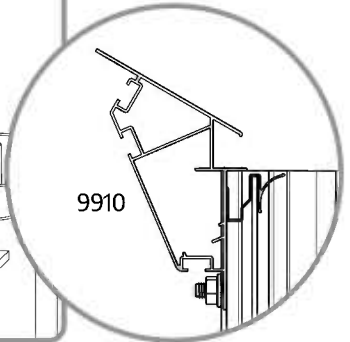
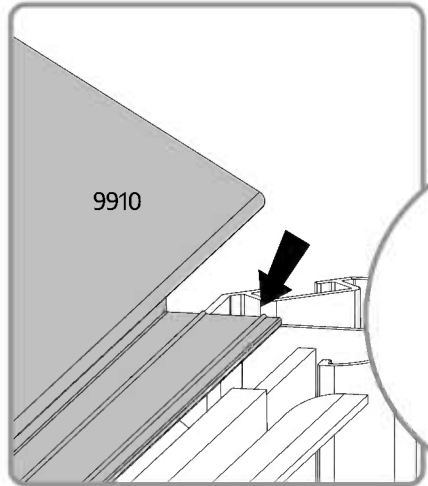
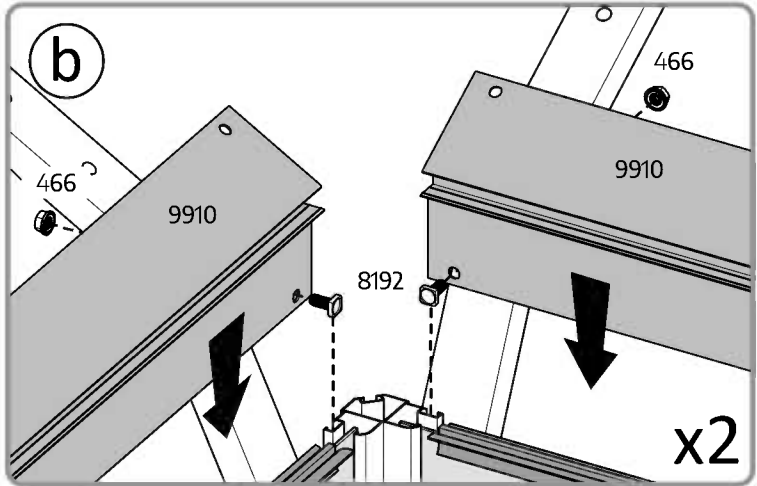
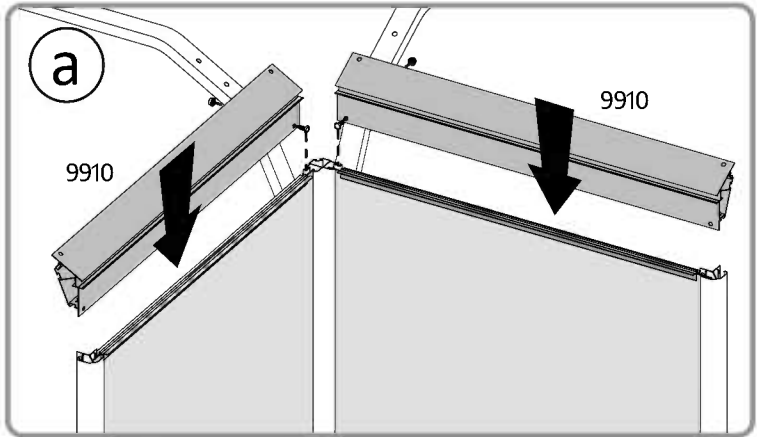
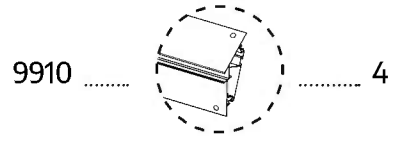
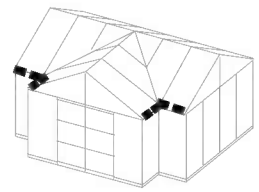

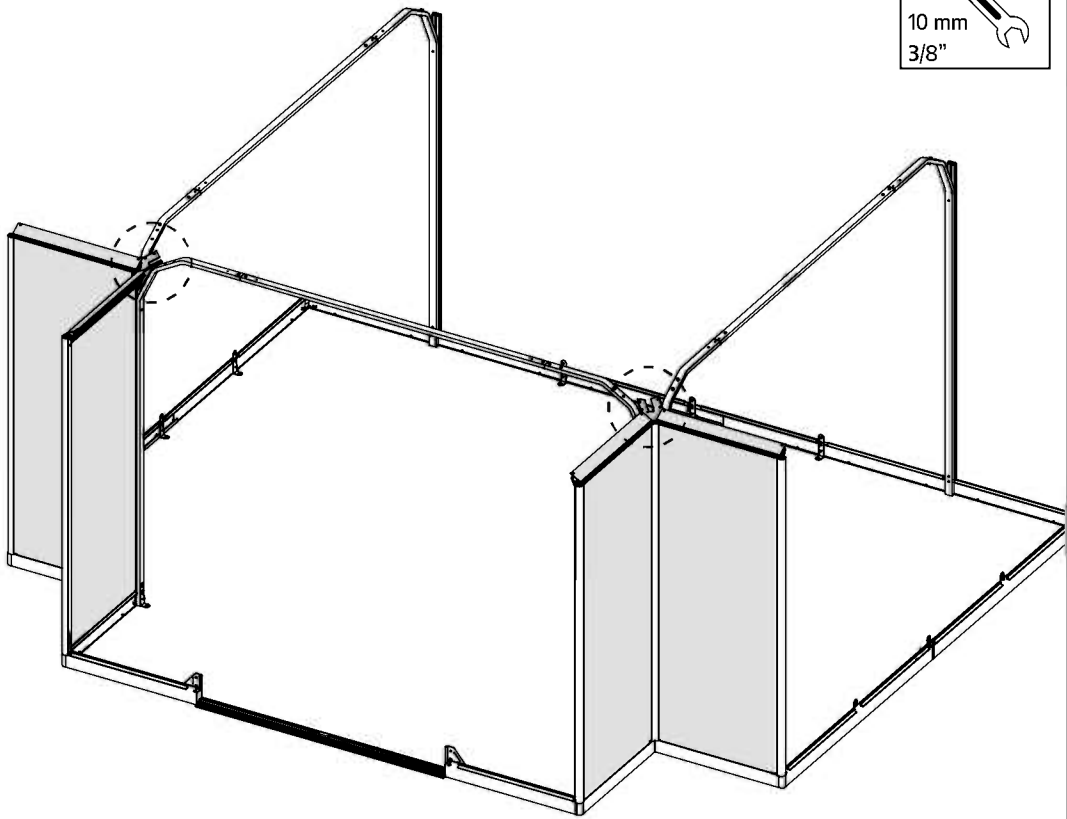
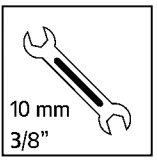
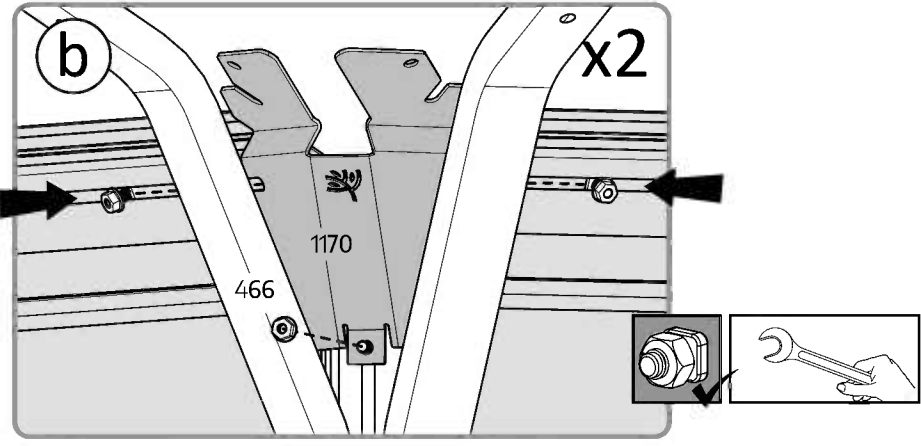
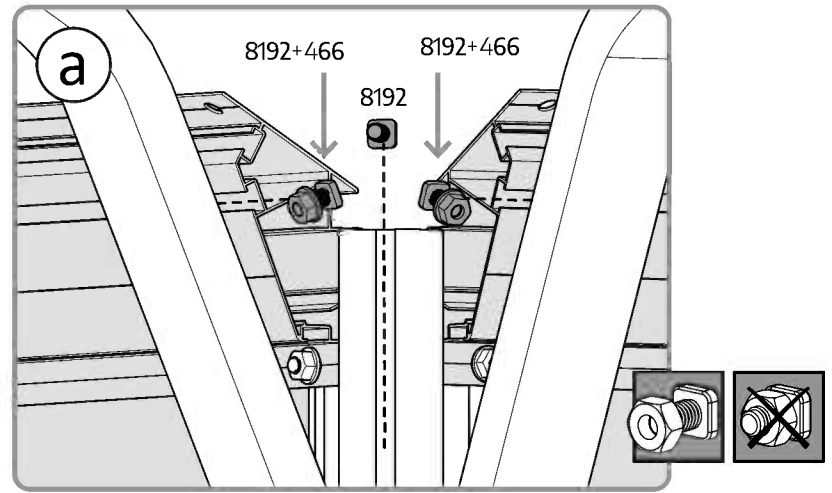
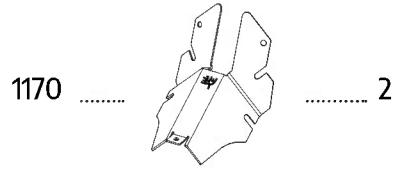
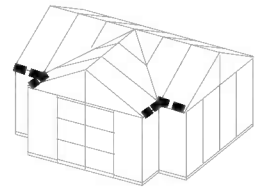



Make sure that the 4 holes of profile **#9923** are in the upper part, as described in the close-up drawing (!).

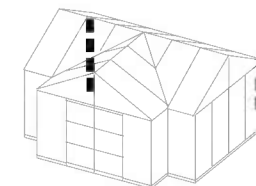

9923 3

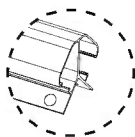

9227 2



8192 6



466 6

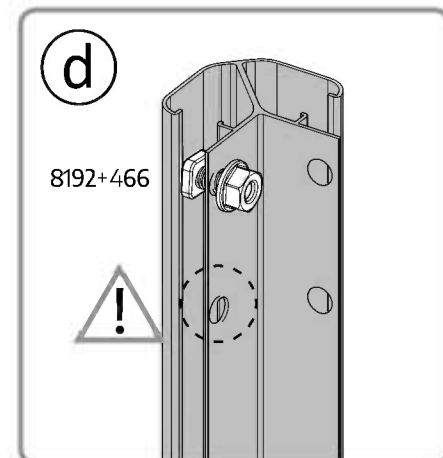
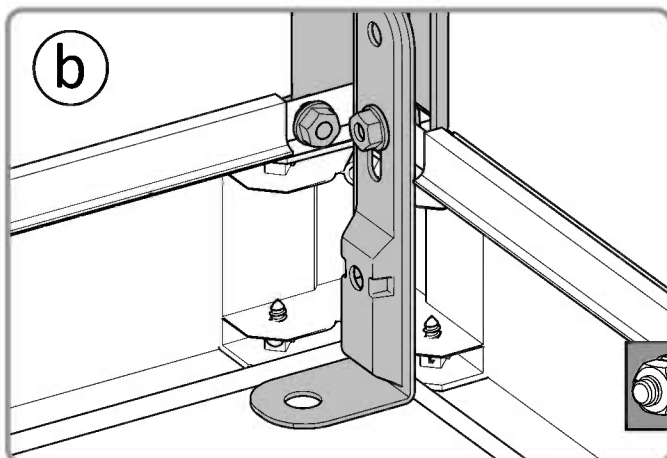
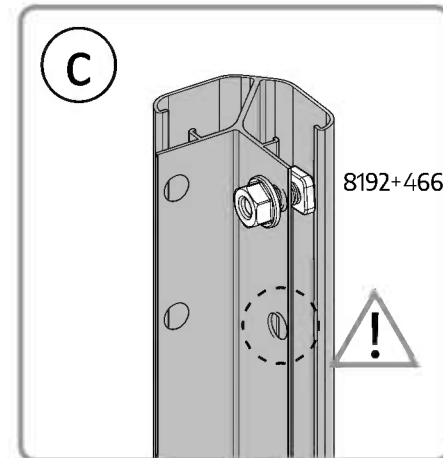
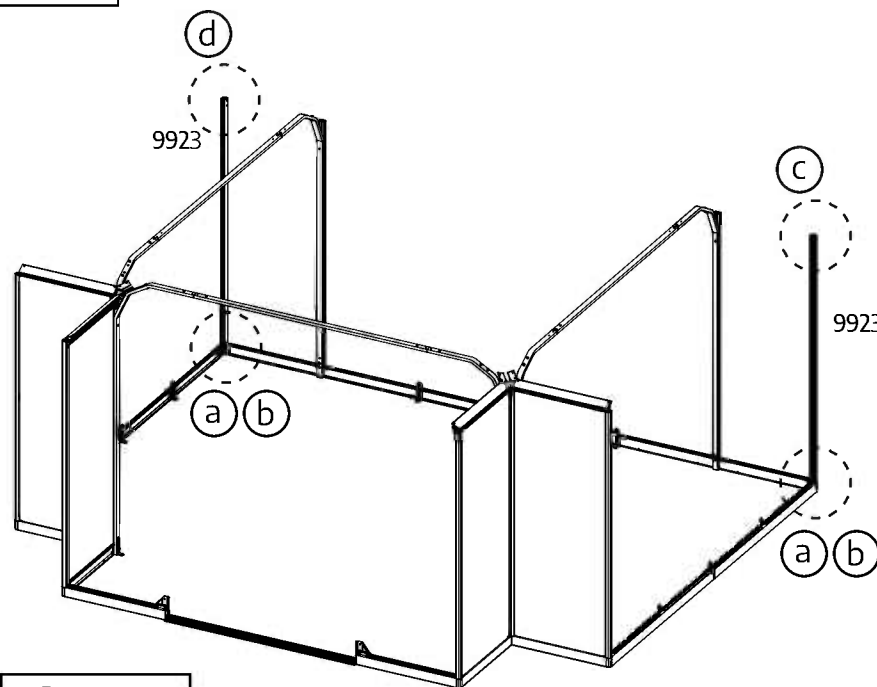
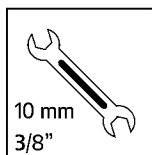
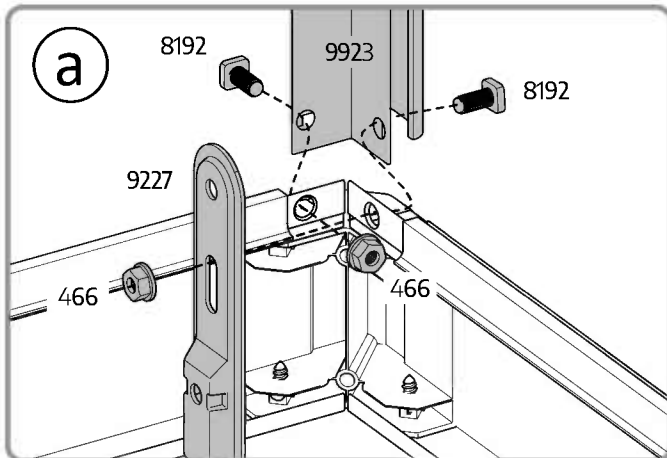

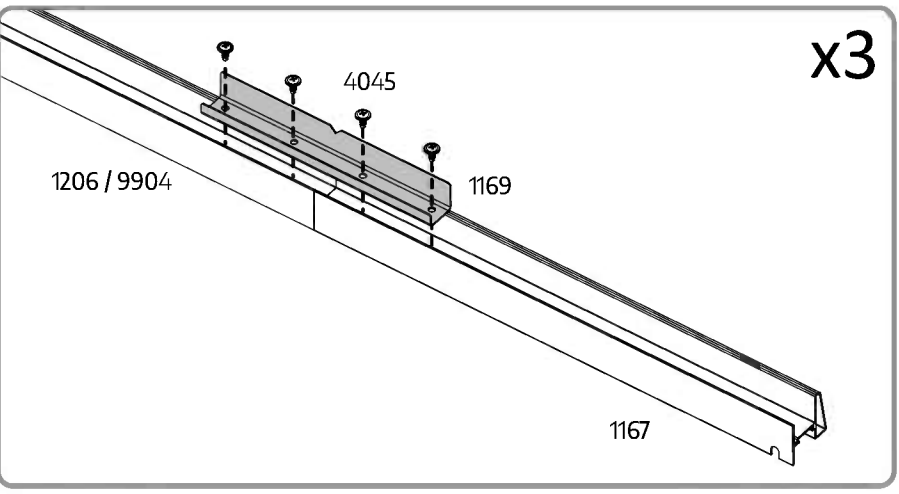
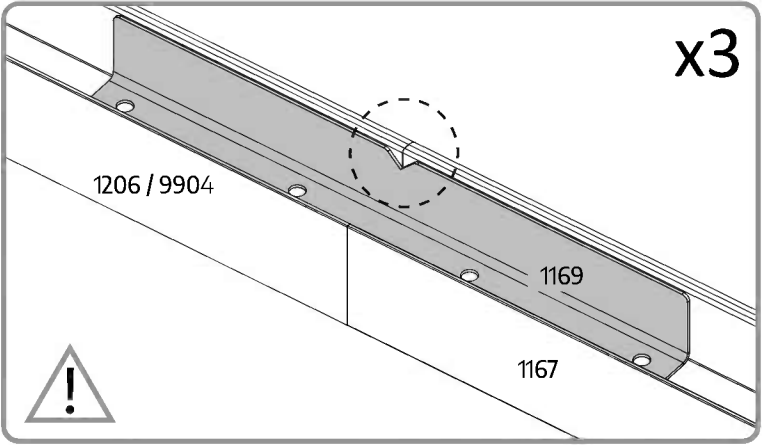
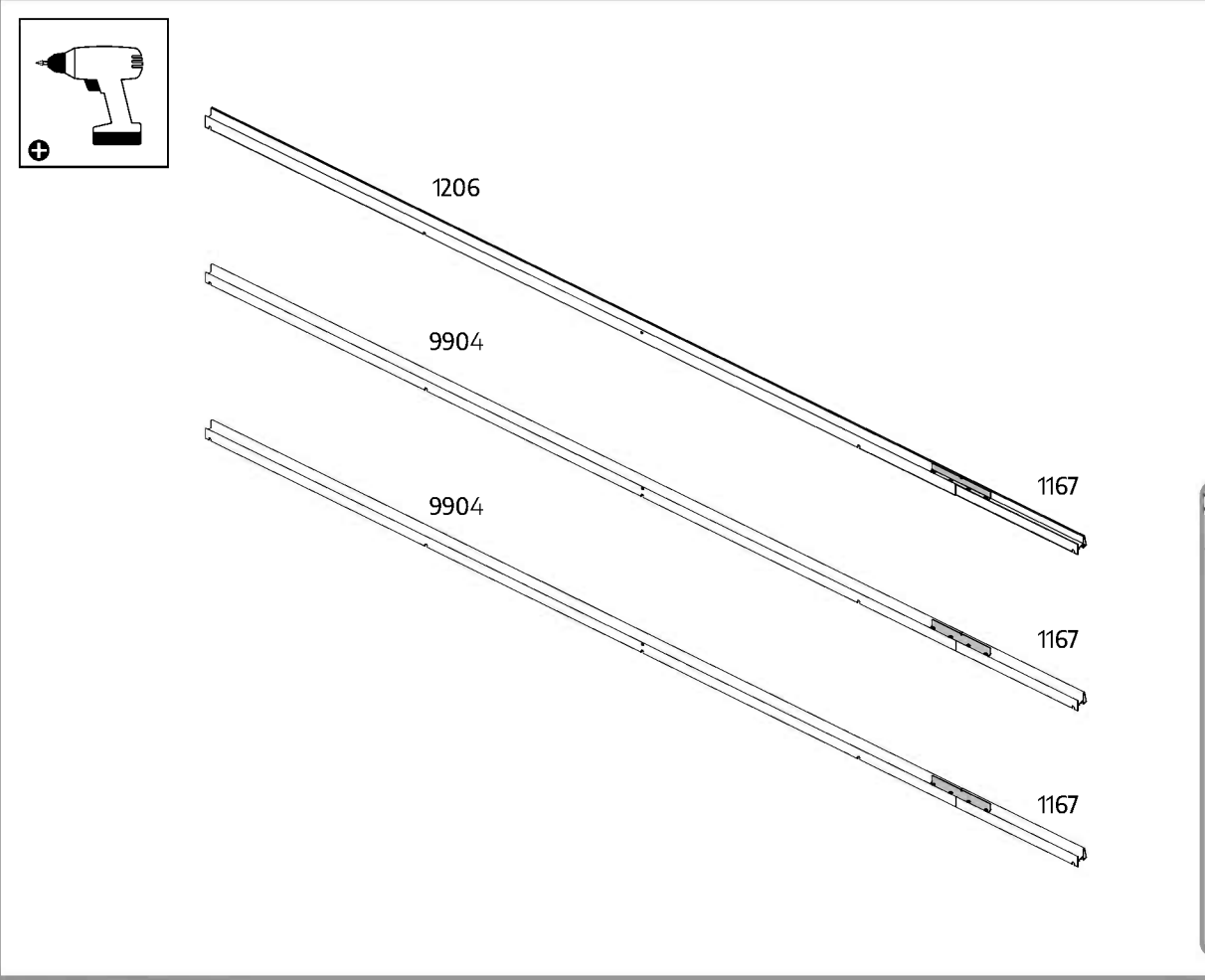
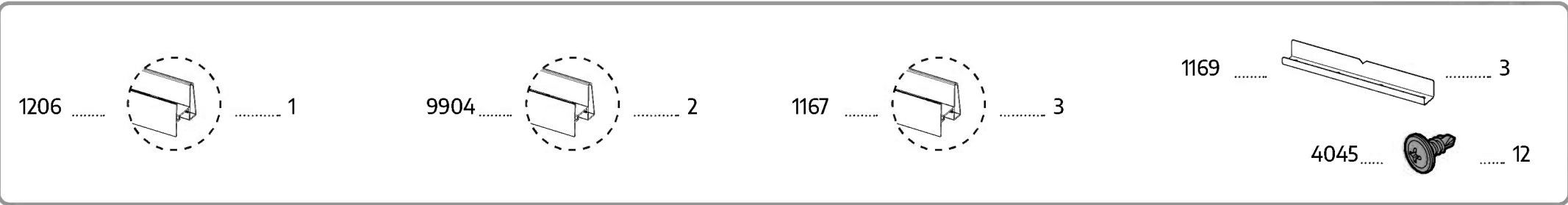
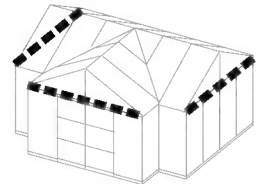

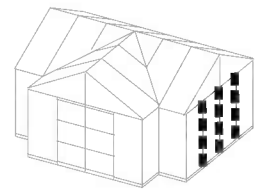

7892 3

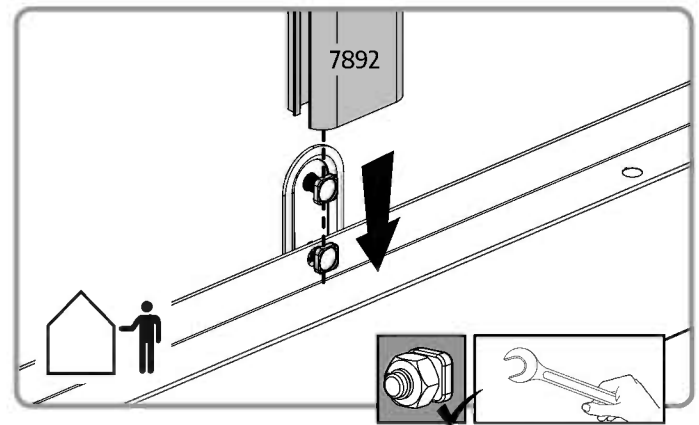
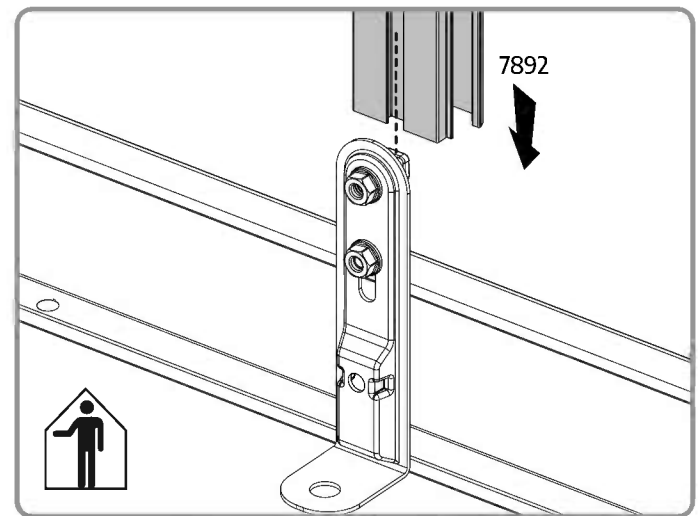
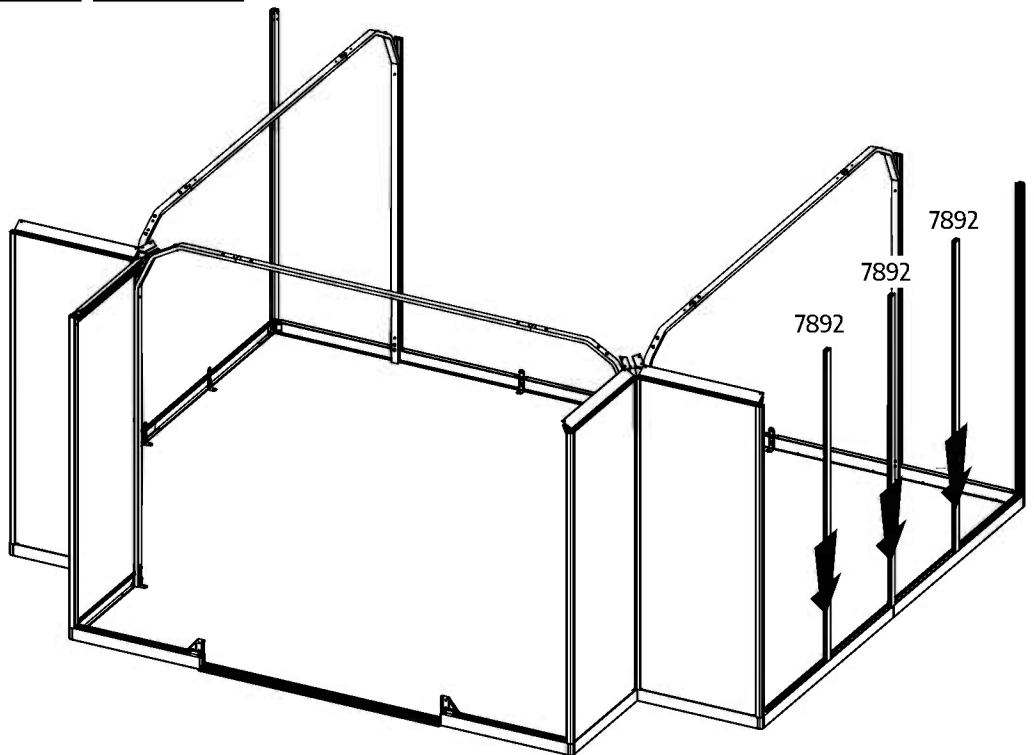
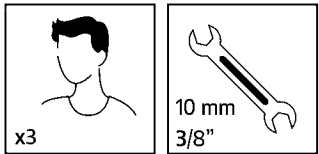

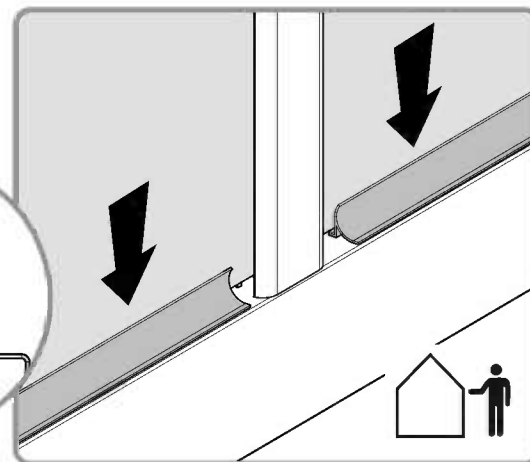
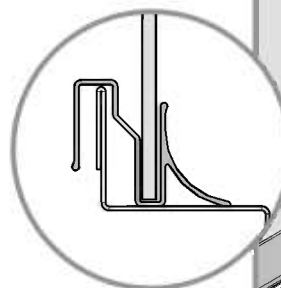
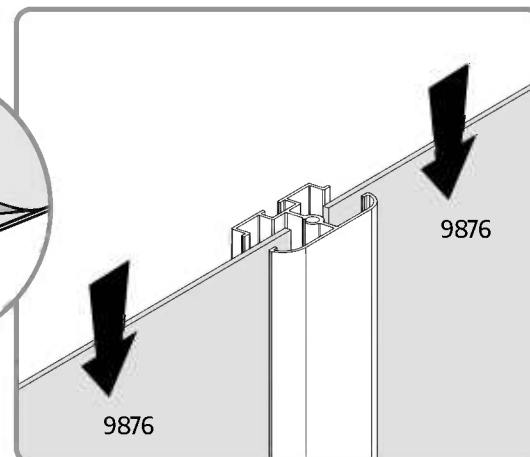
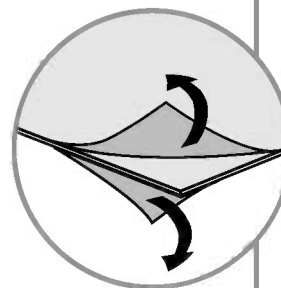
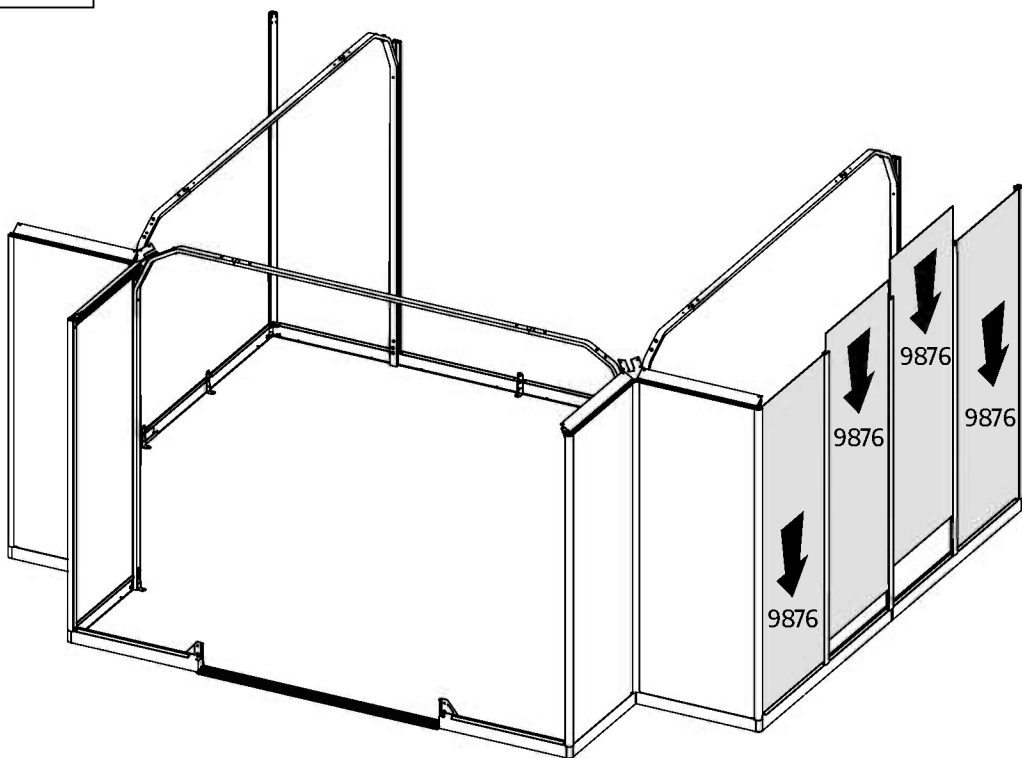
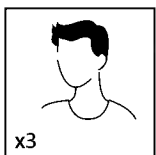
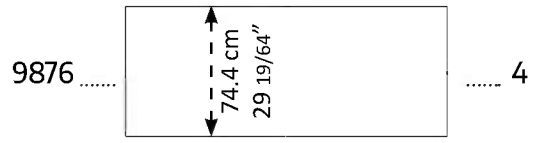
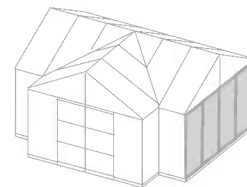

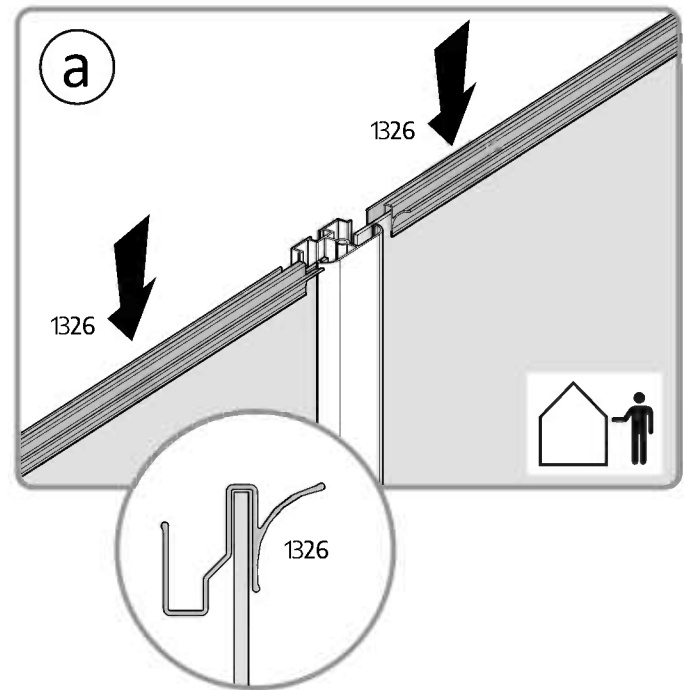
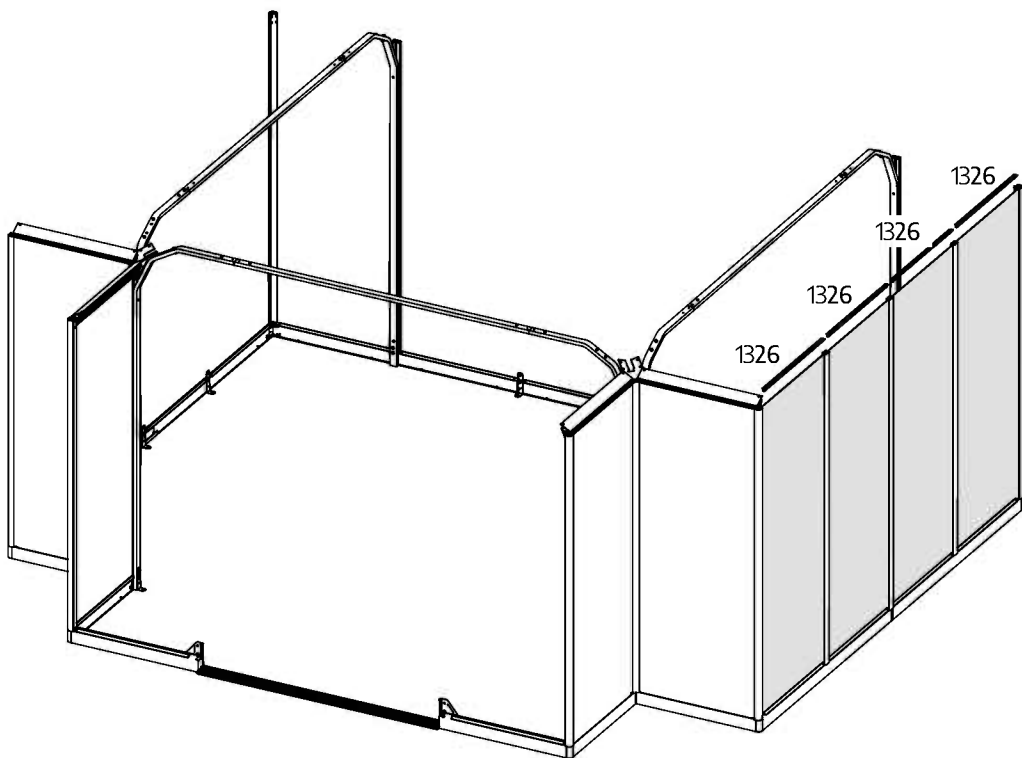
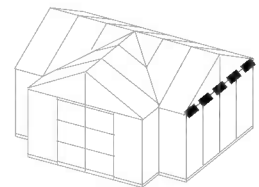

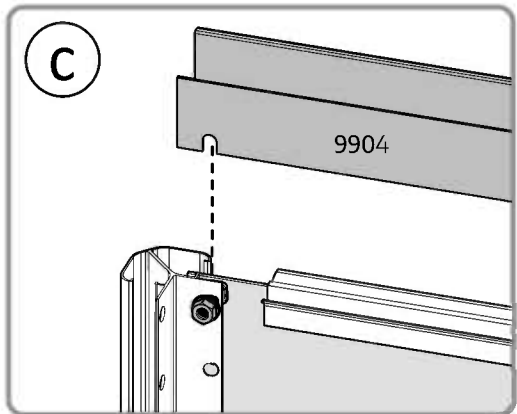
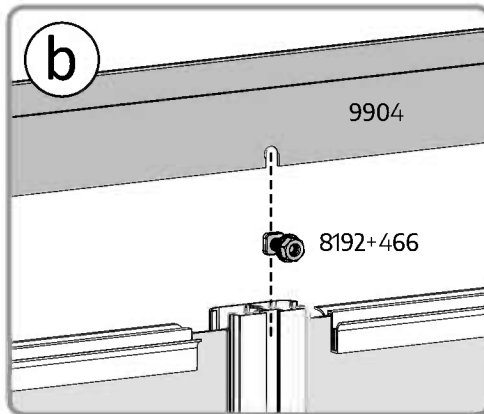
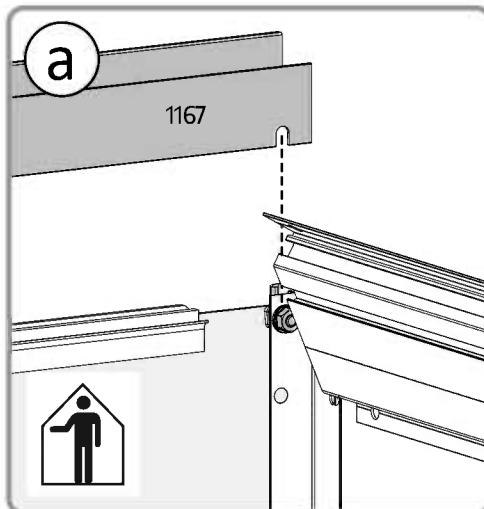
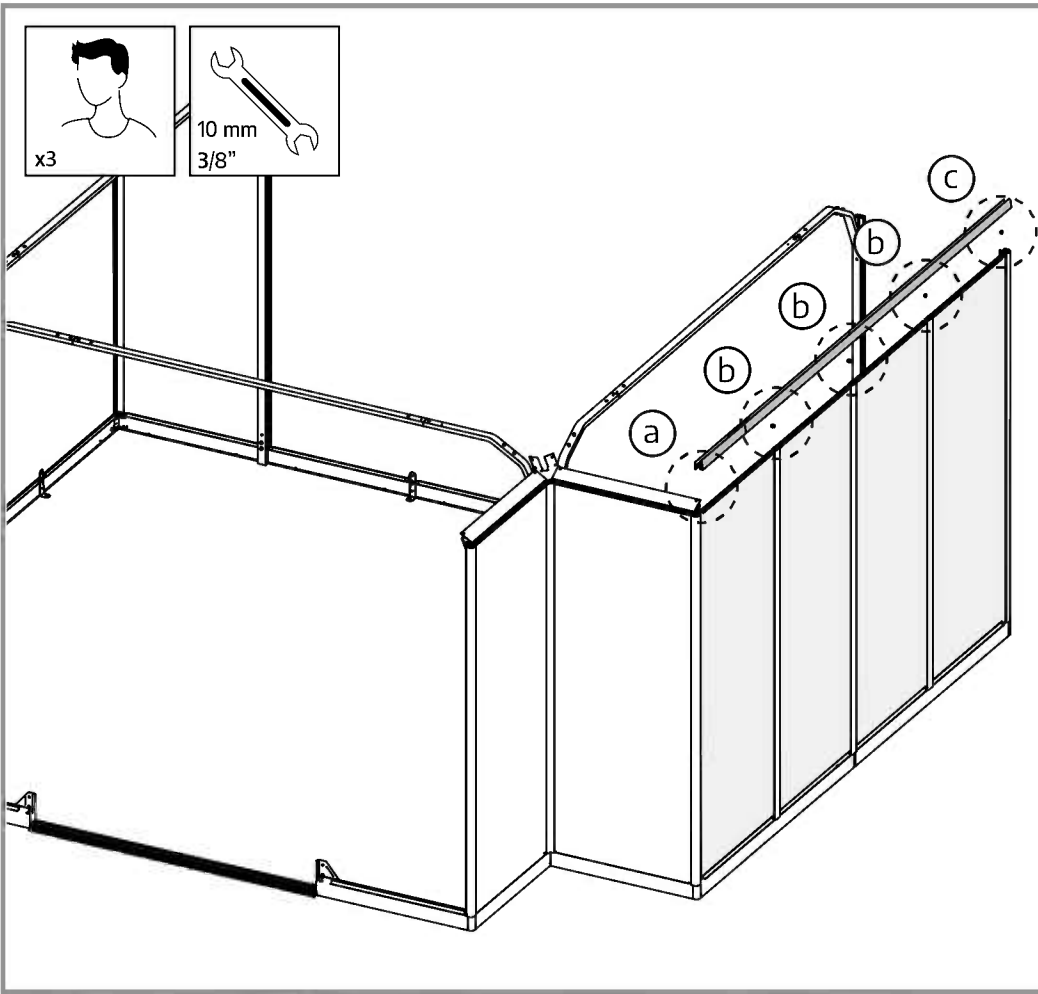
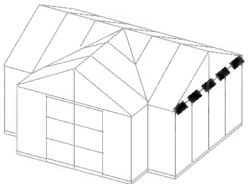

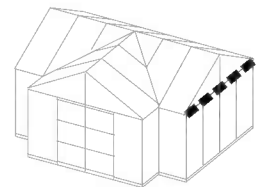

8192  1 466  1

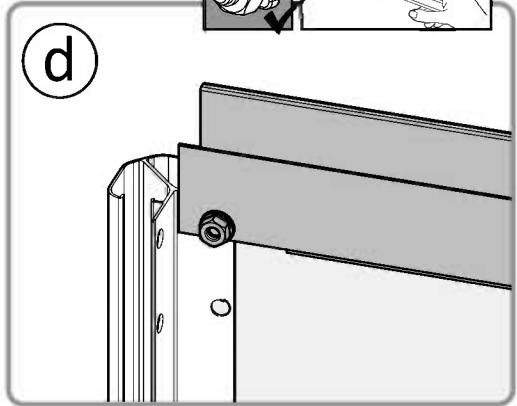
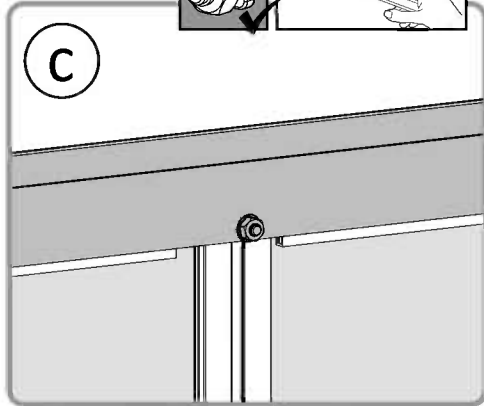
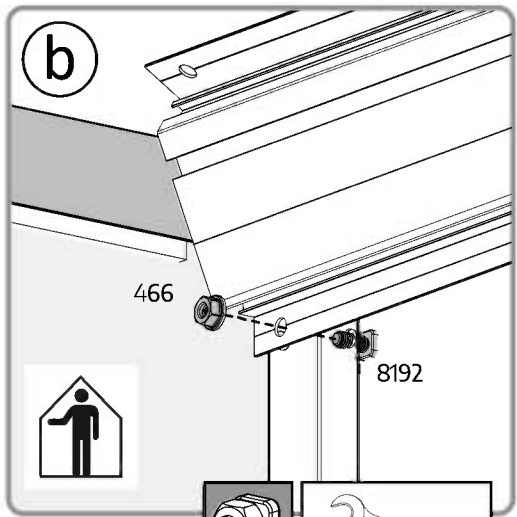
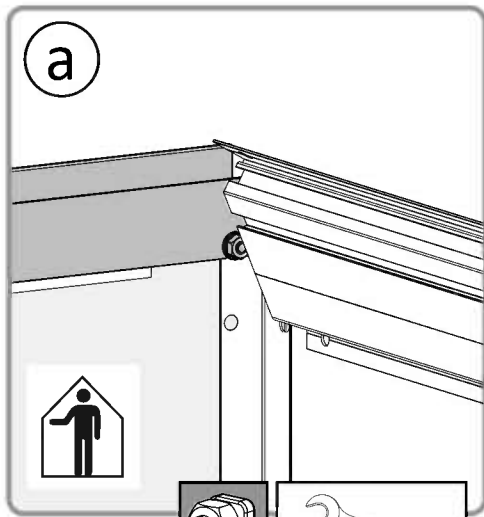
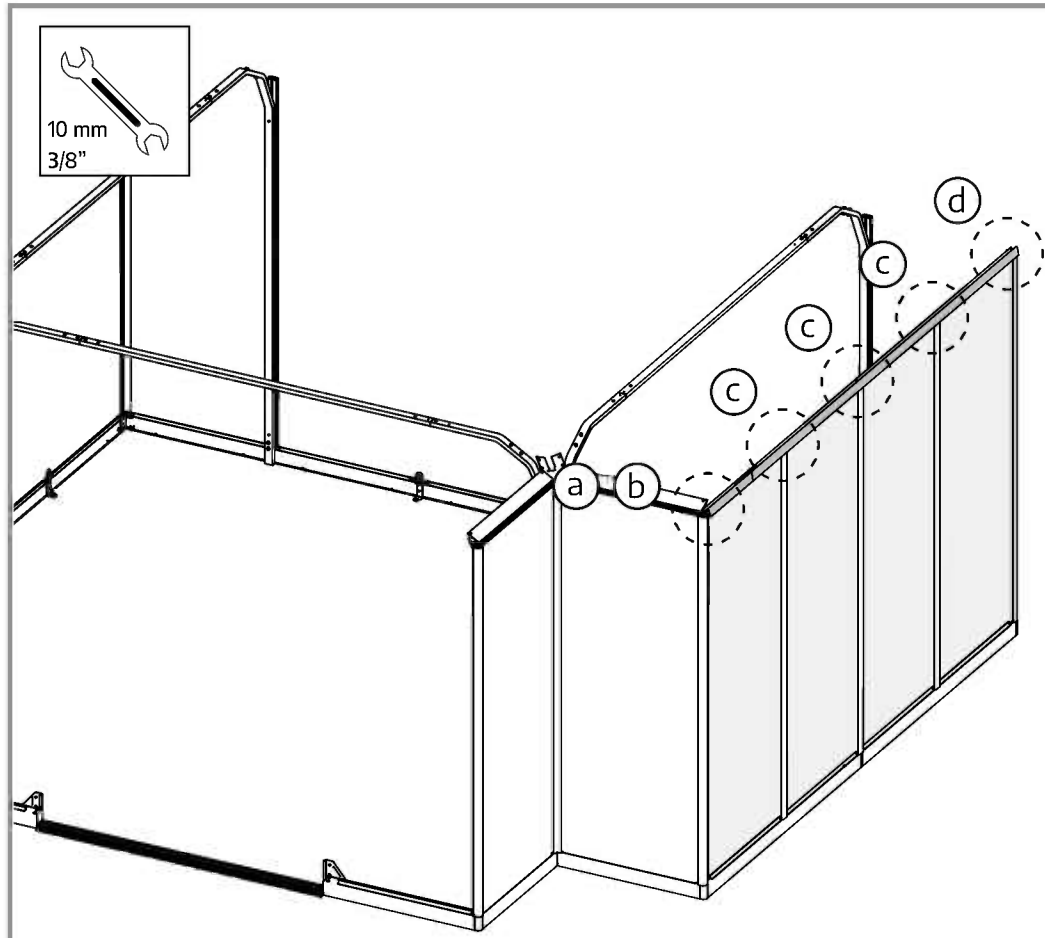

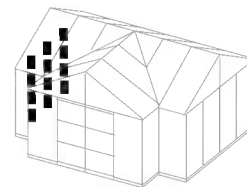

7892 3

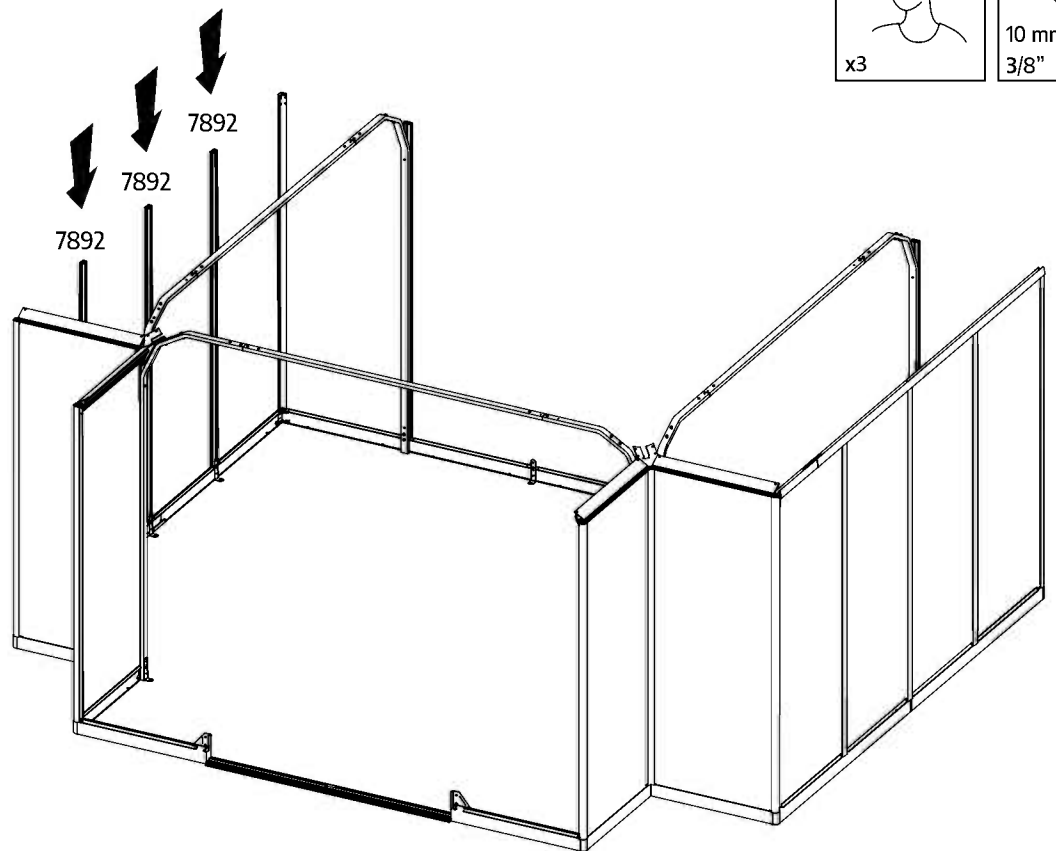
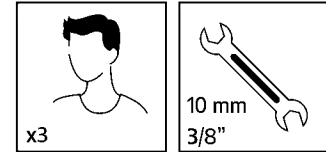
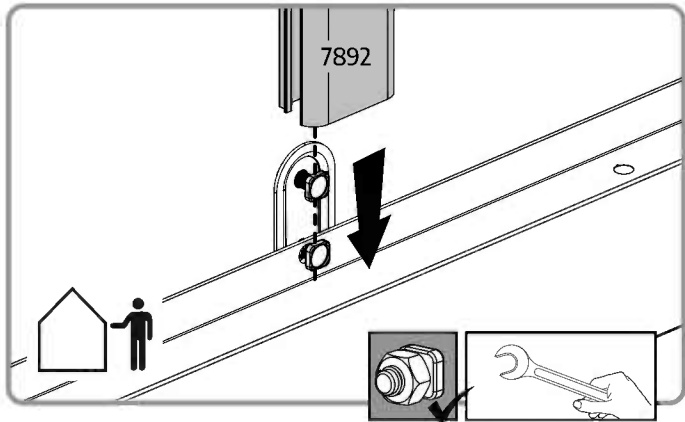
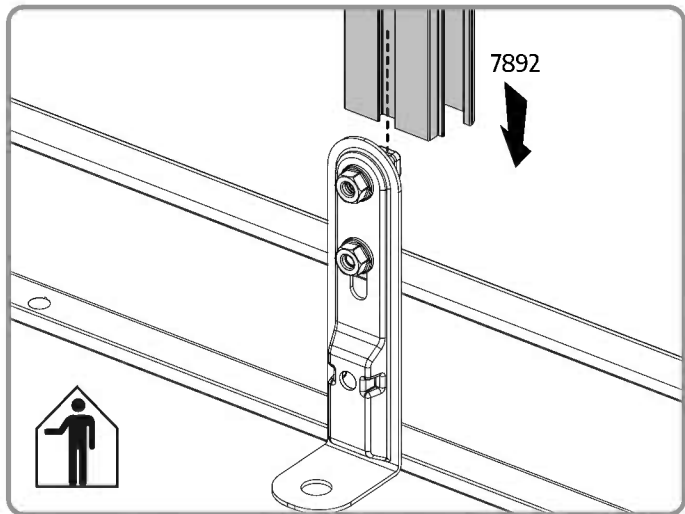

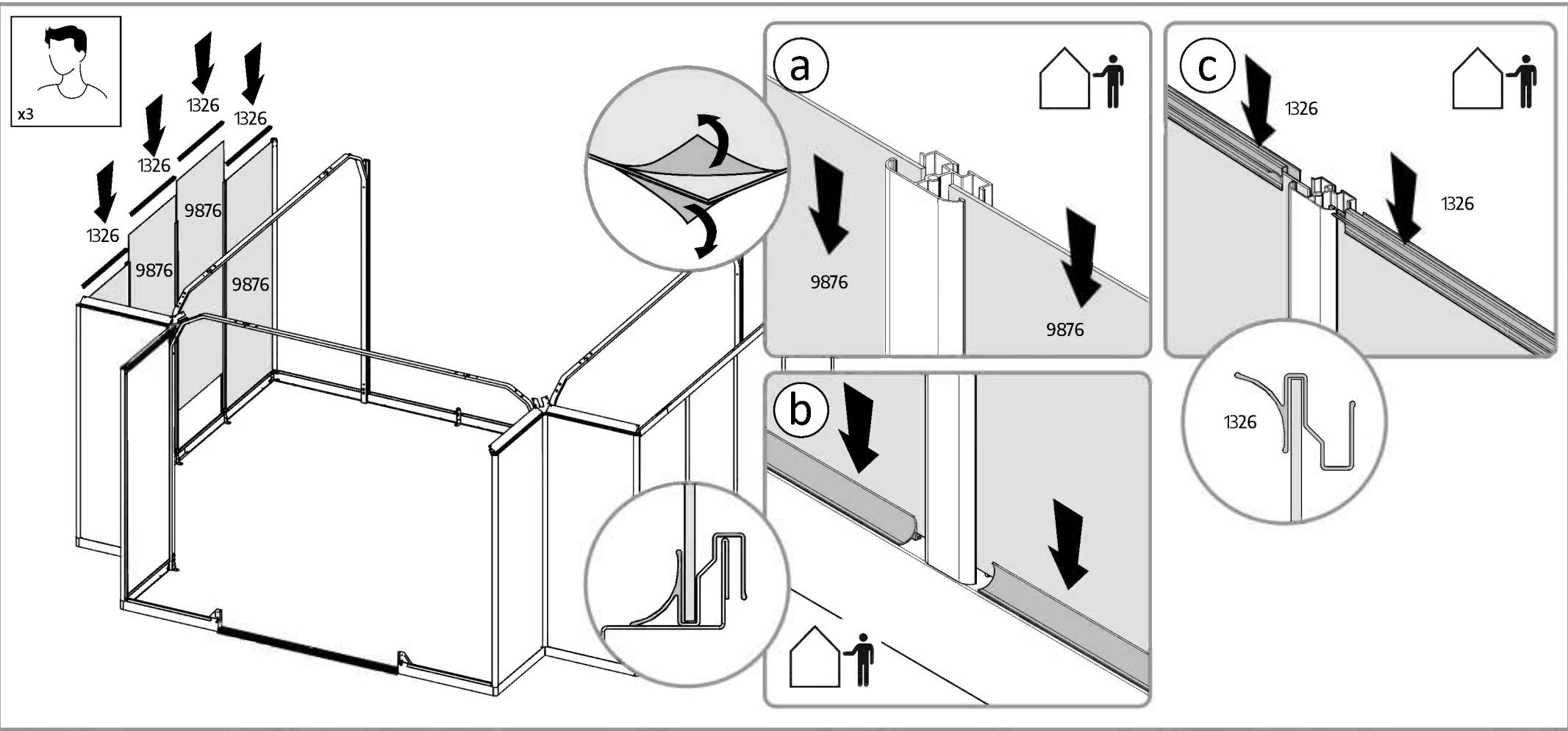
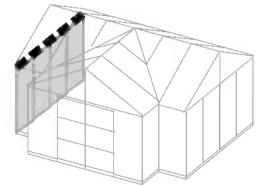

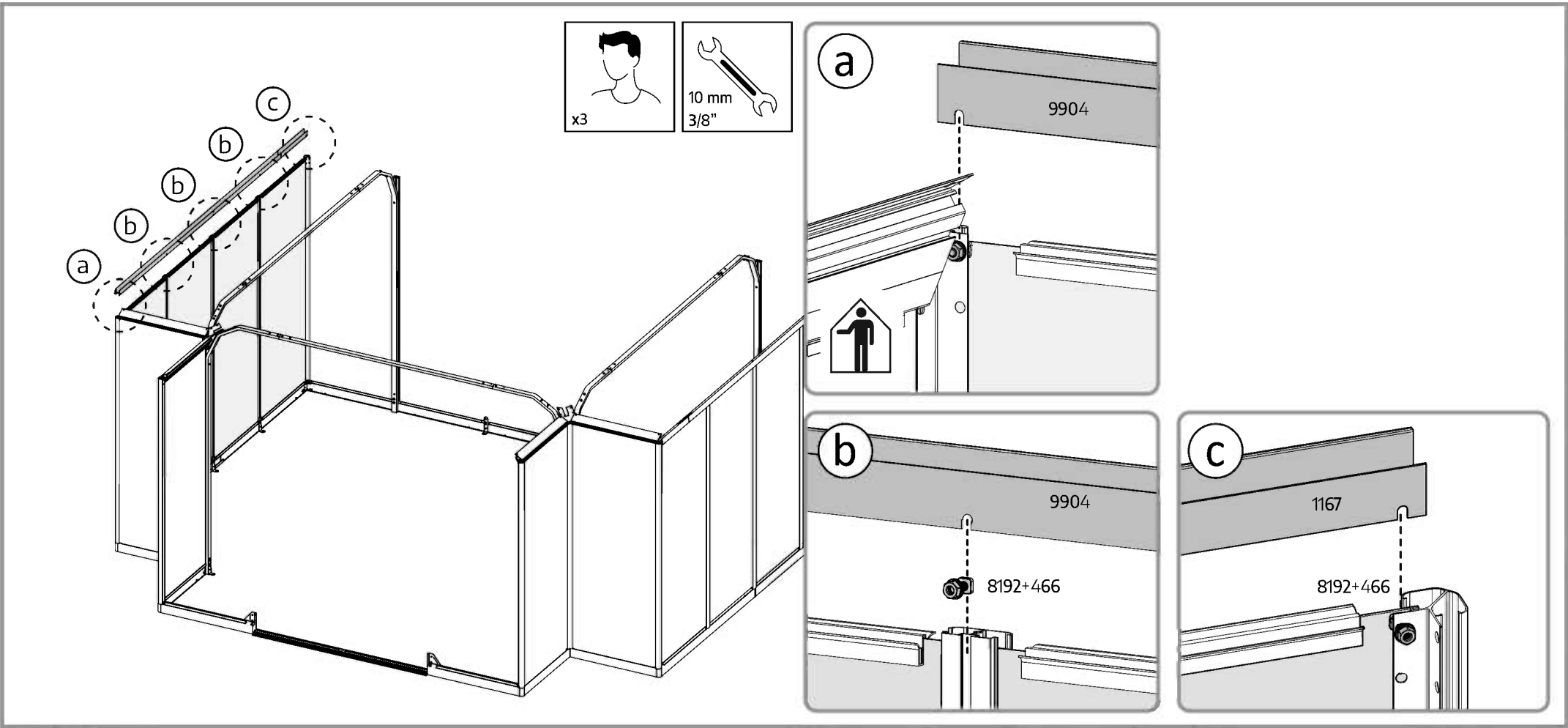
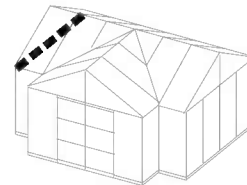

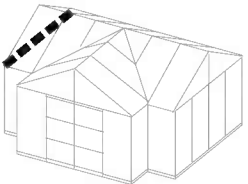

8192  1 466  1

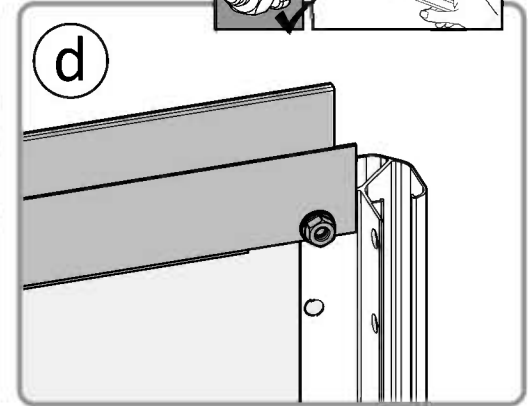
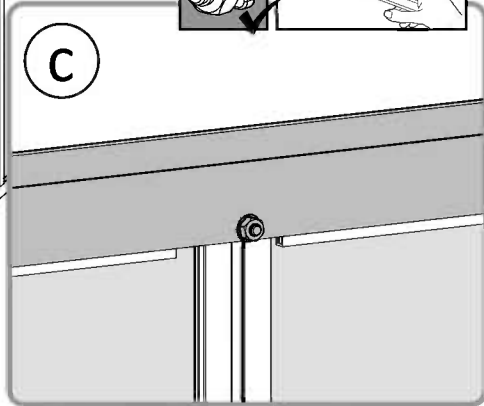
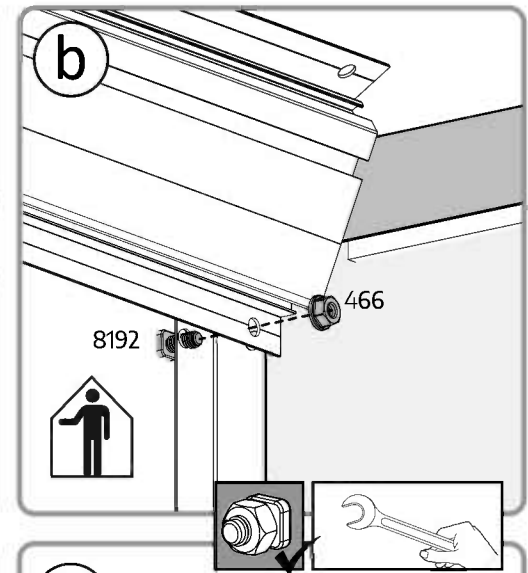
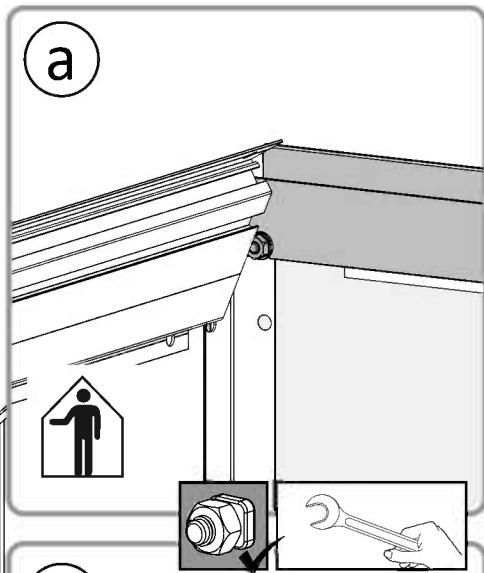
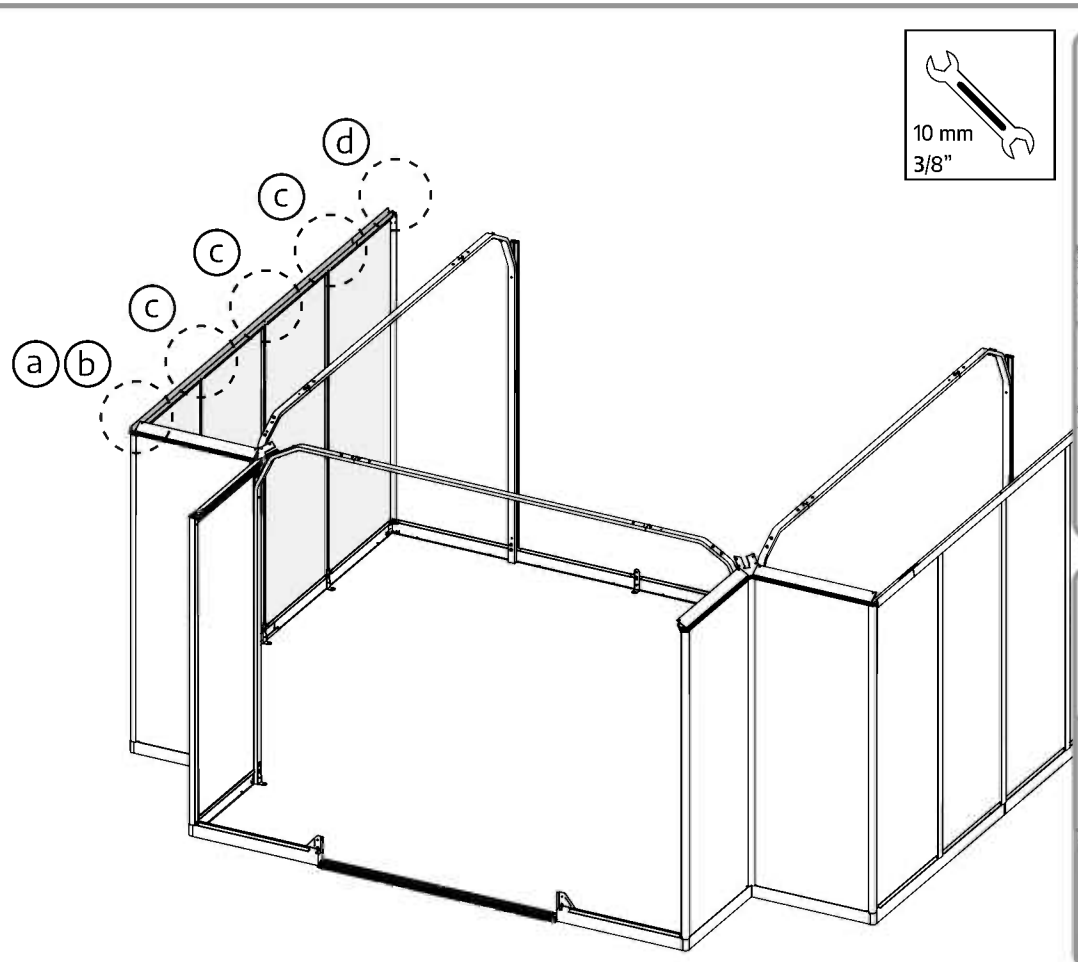

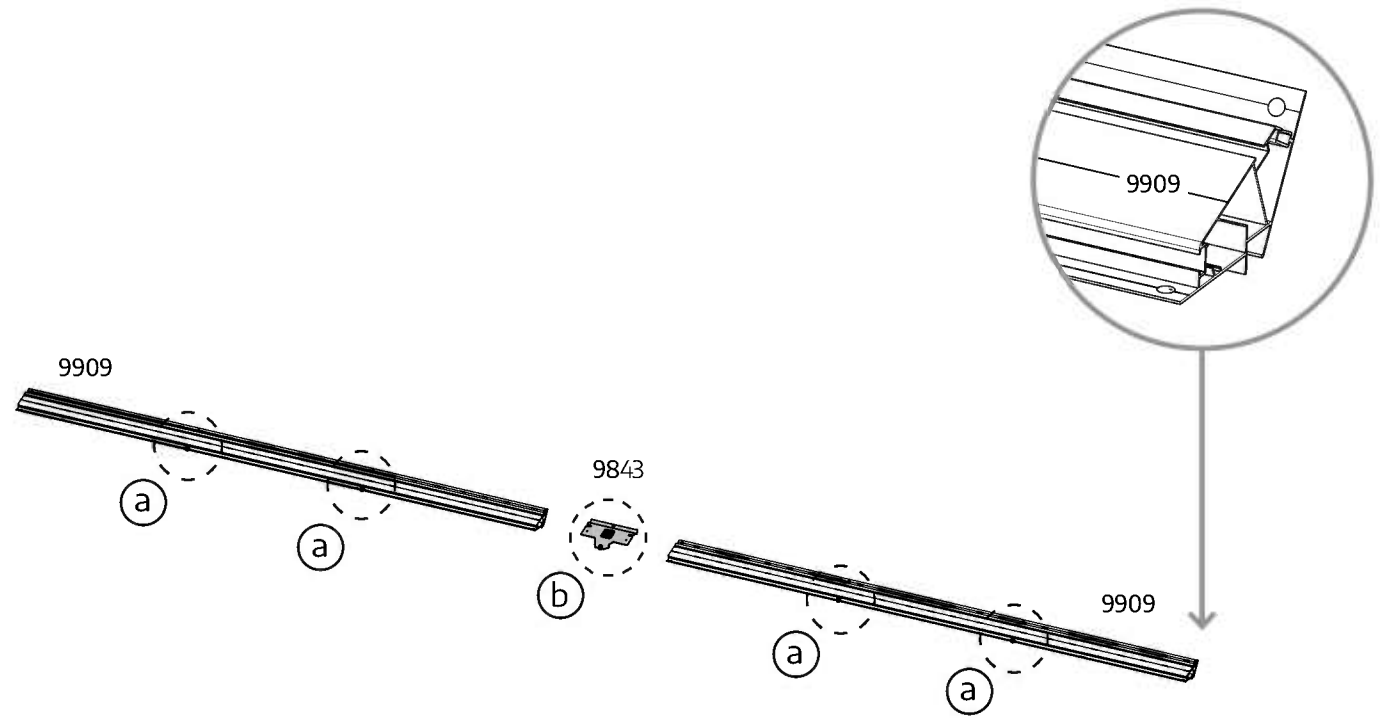
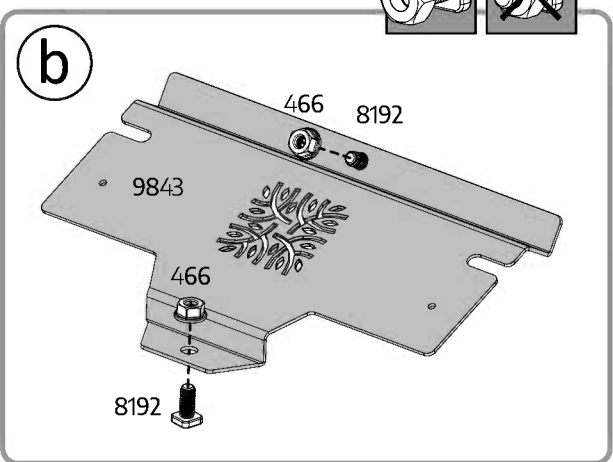
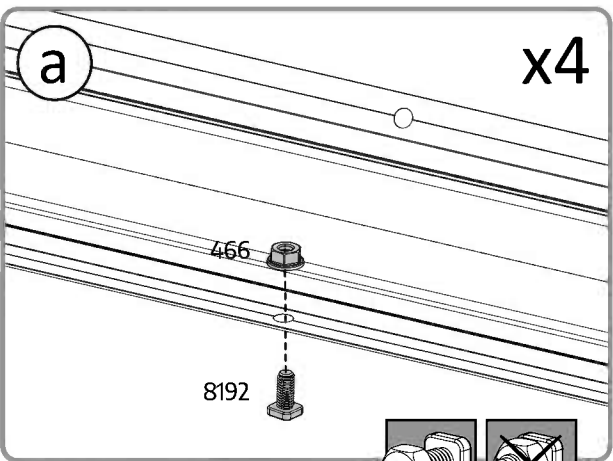
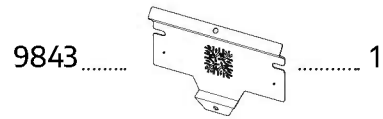
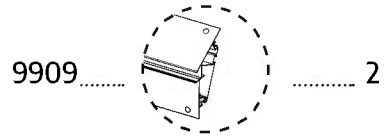
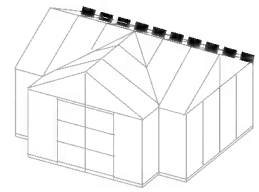

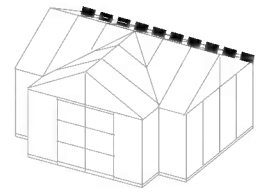

- 9009.....  1
- 1257  1
- 8192  2
- 466  2
- 4008  2

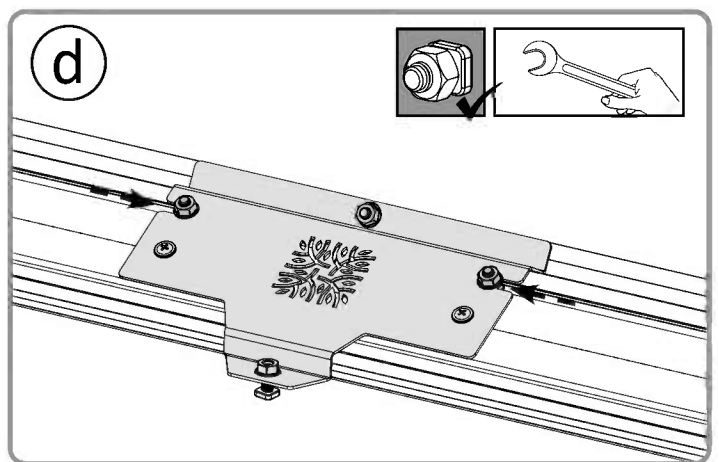
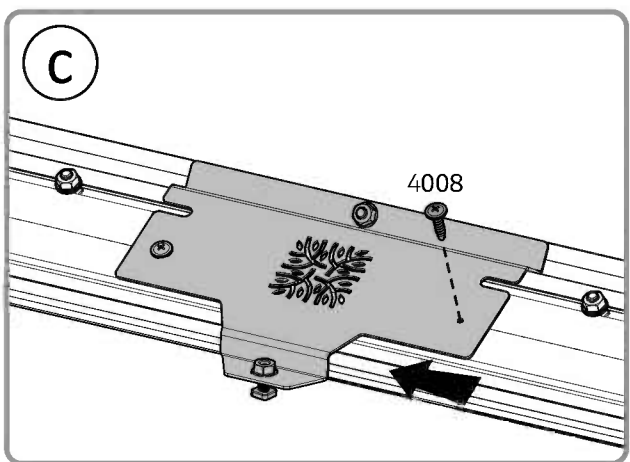
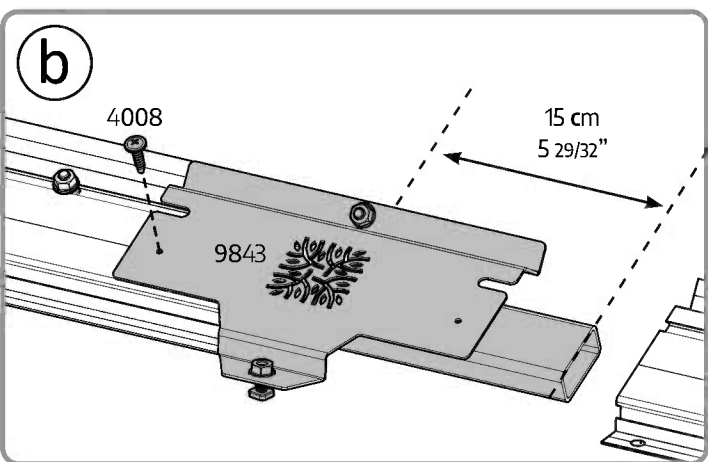
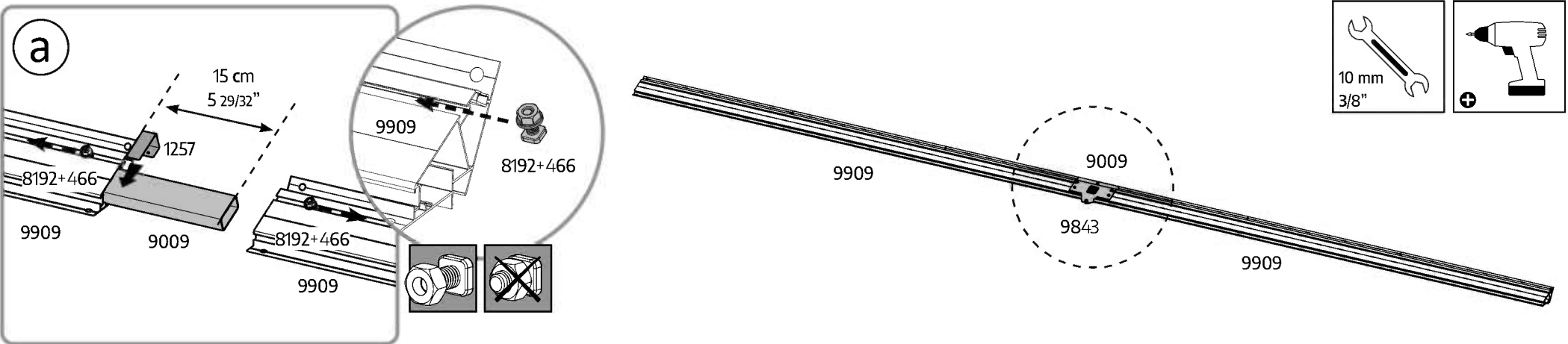

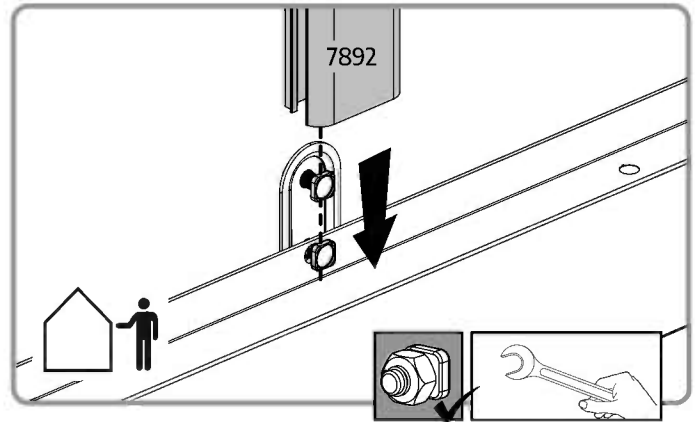
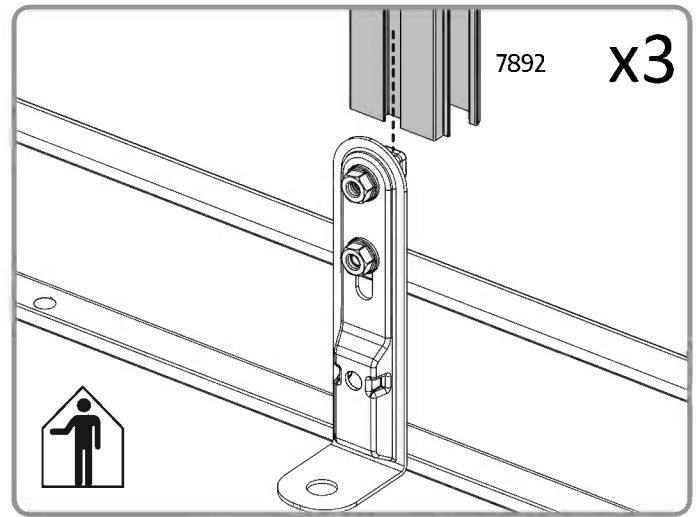
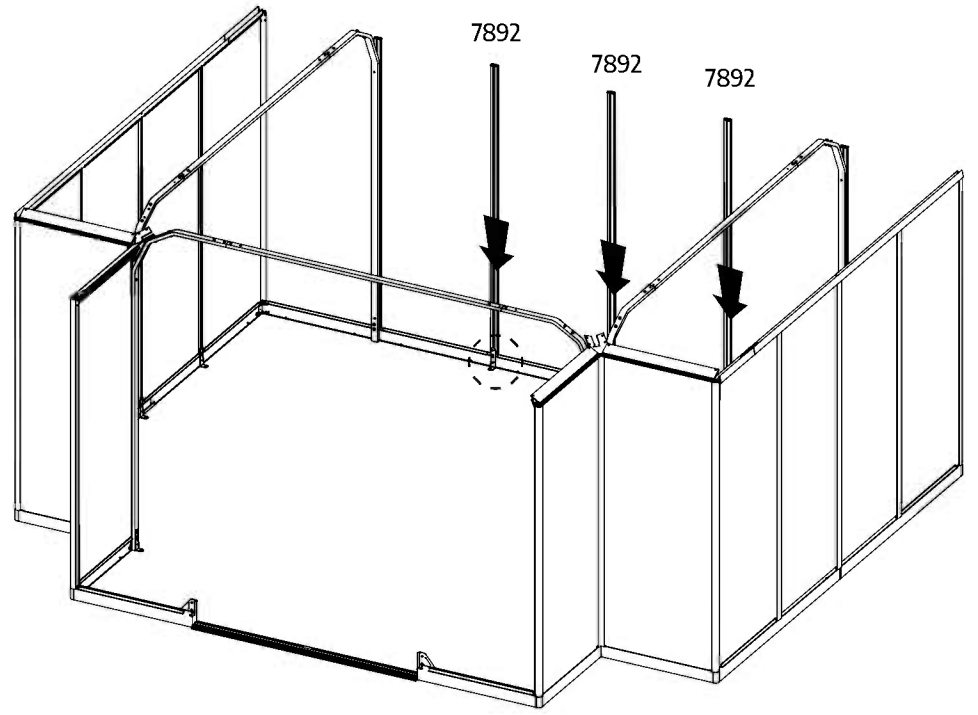
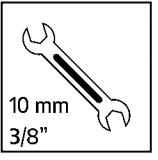
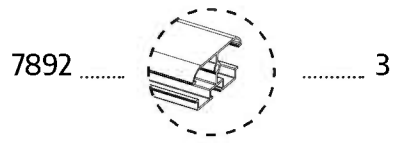
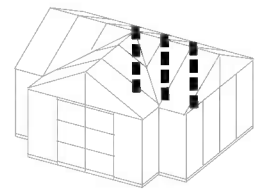

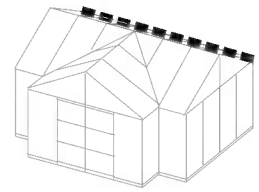

8192  2 466  2

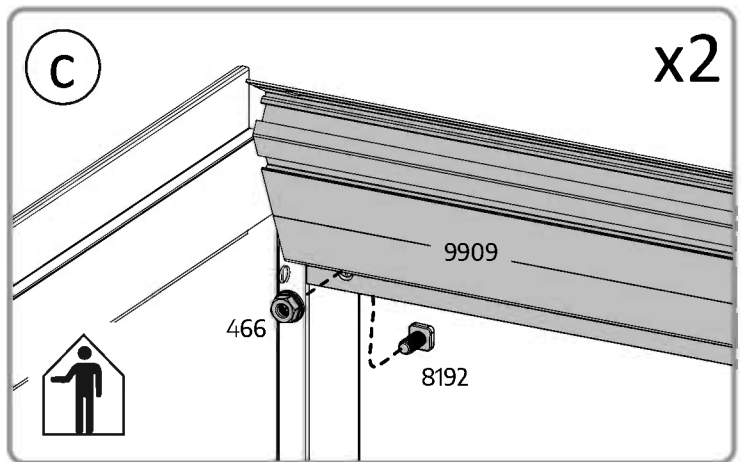
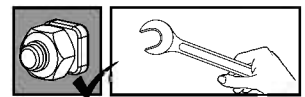
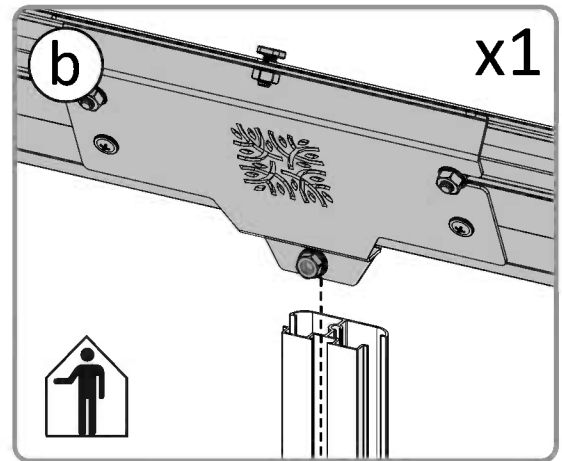
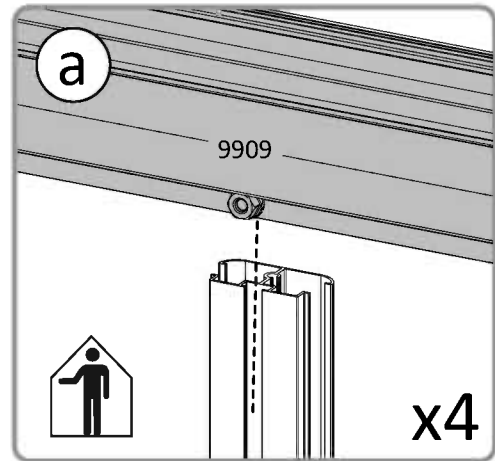
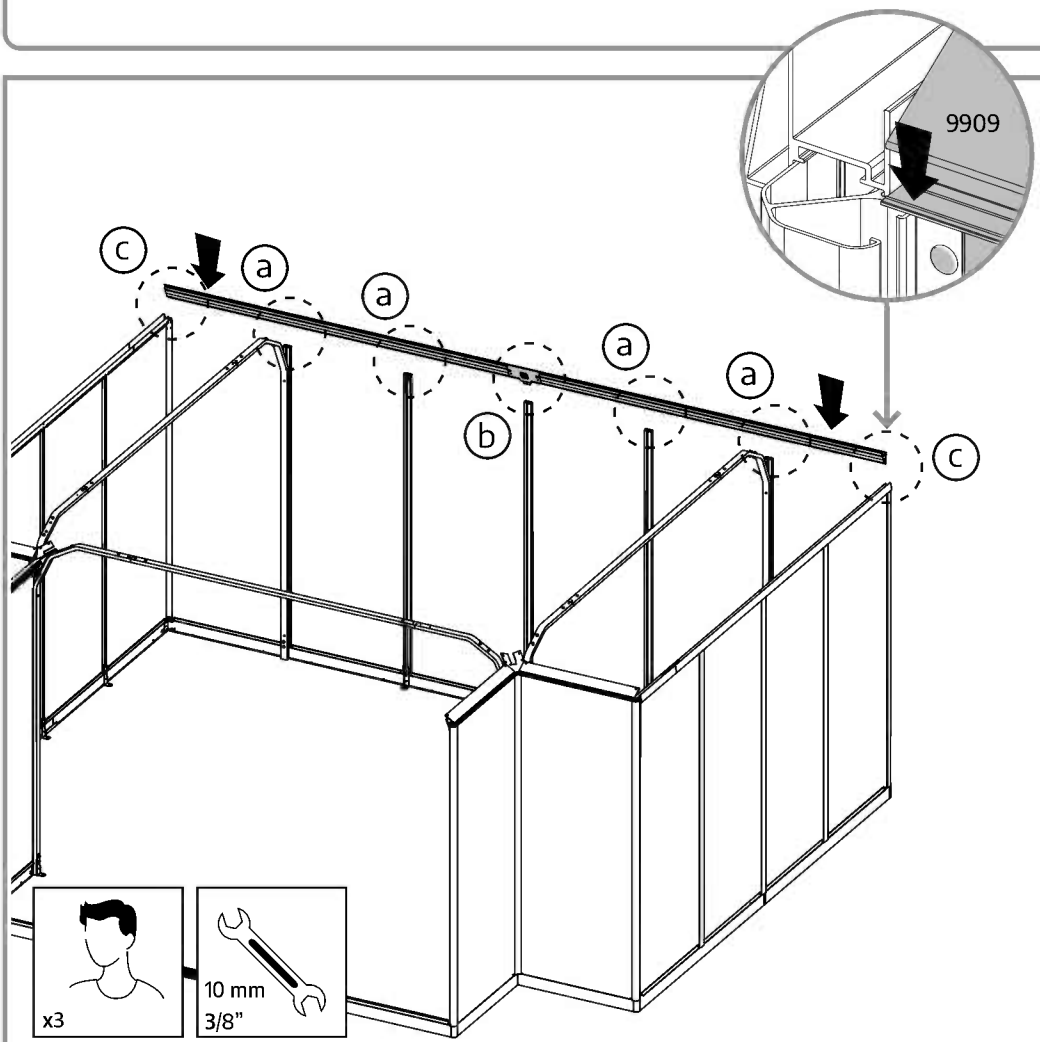

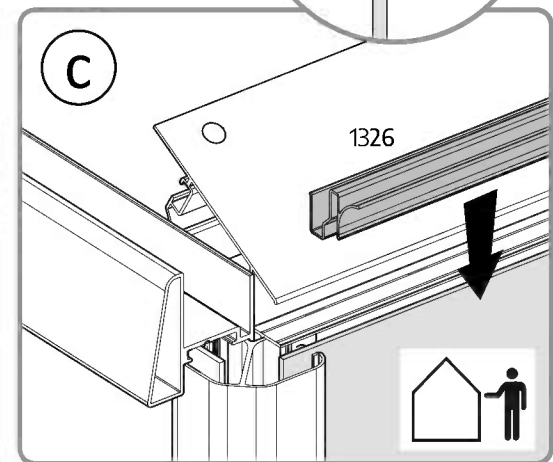
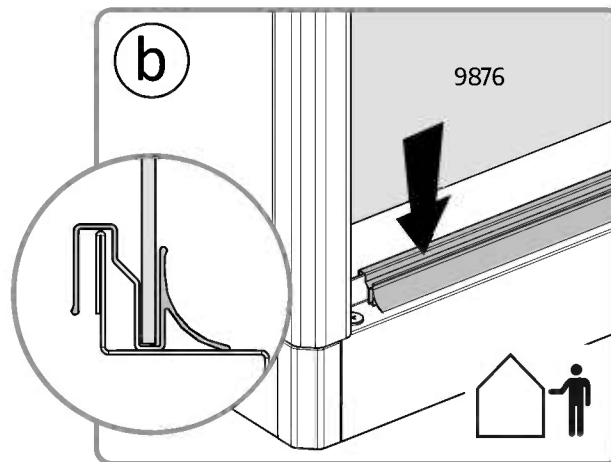
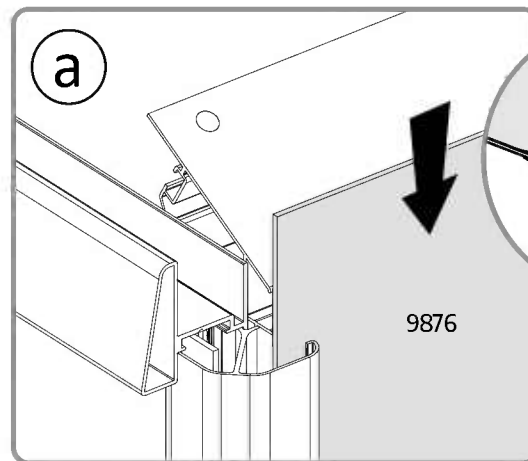
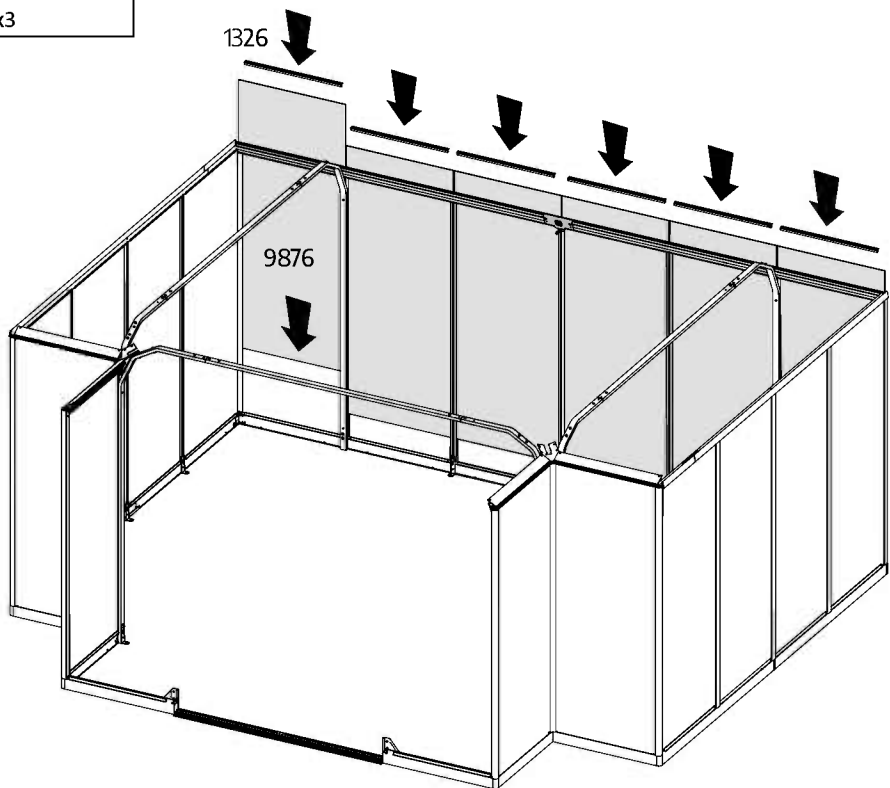
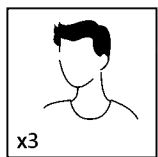
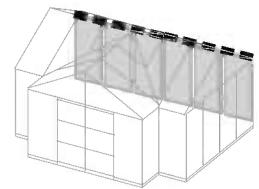

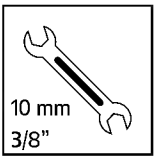
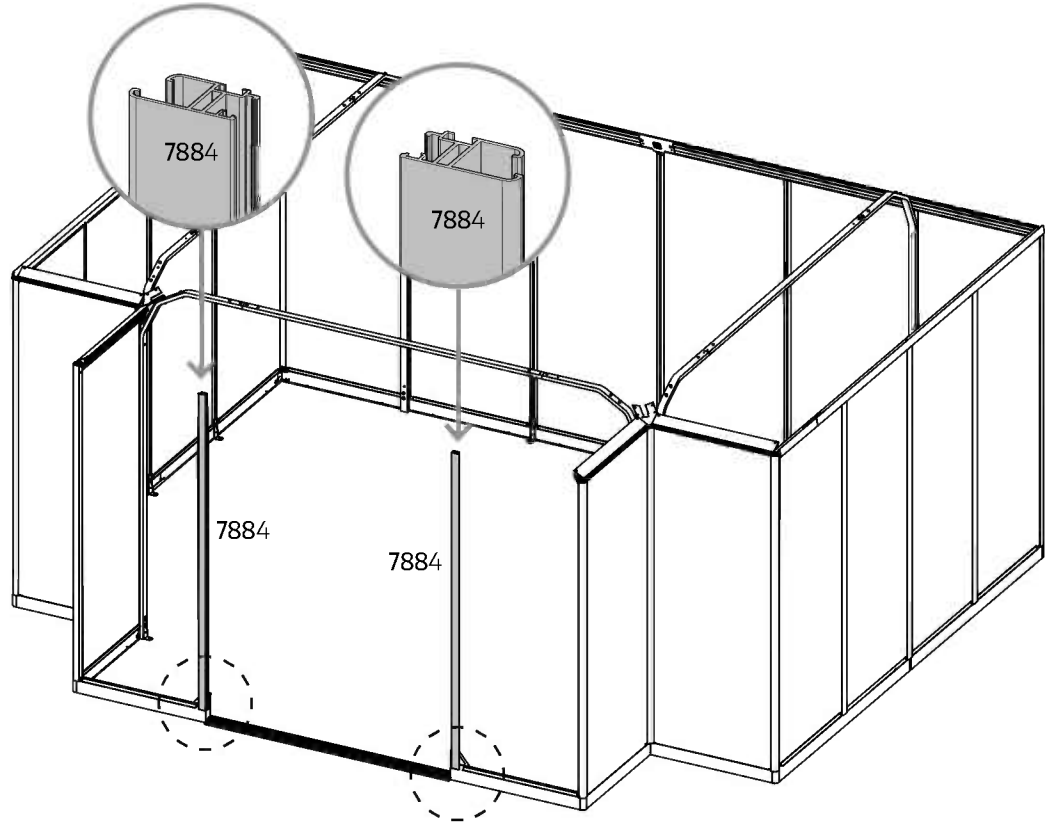
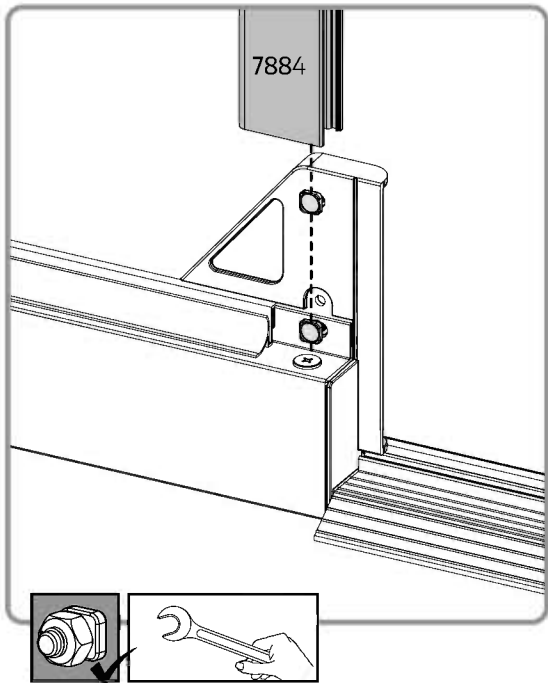
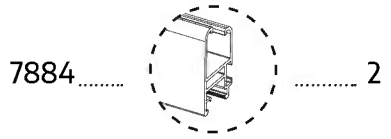
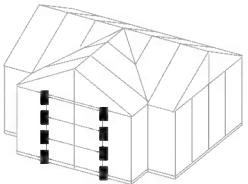

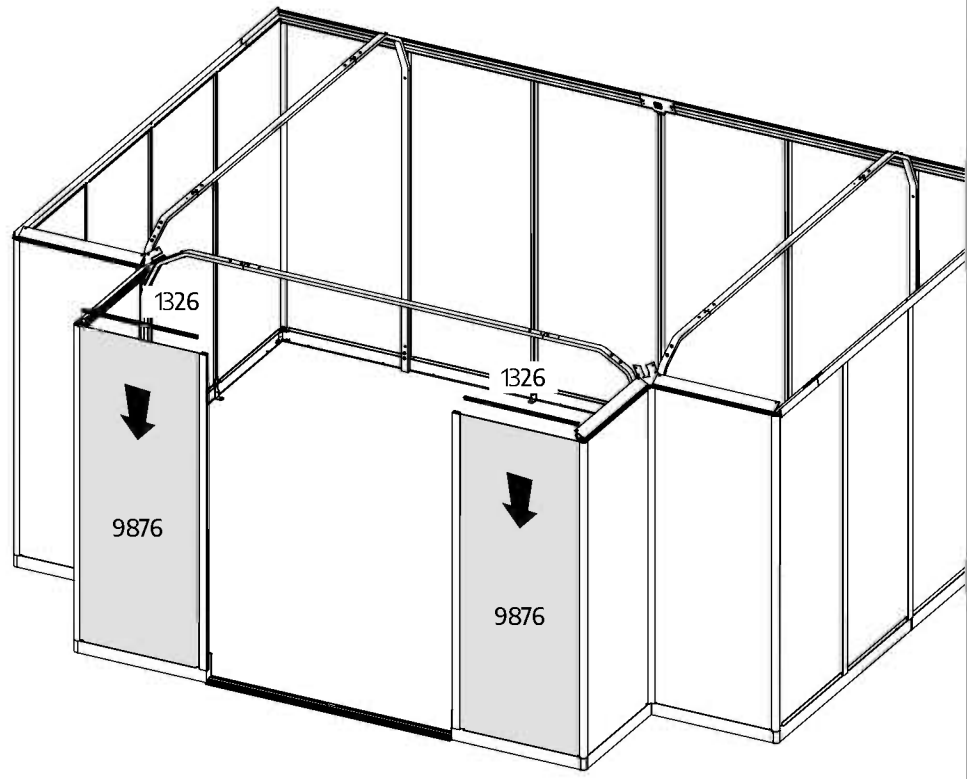
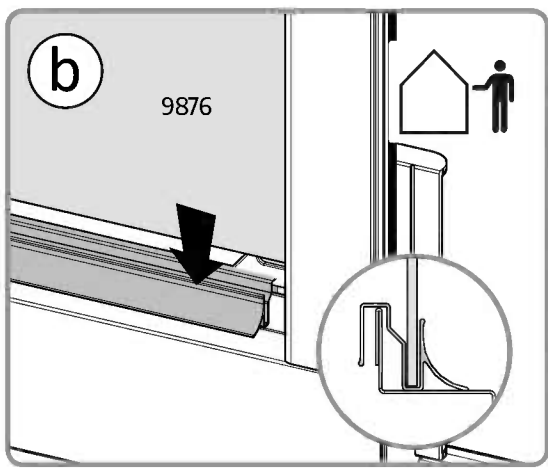
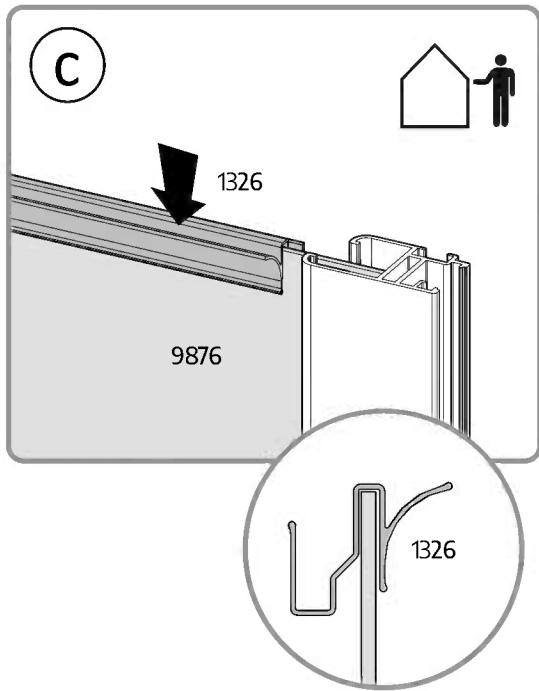
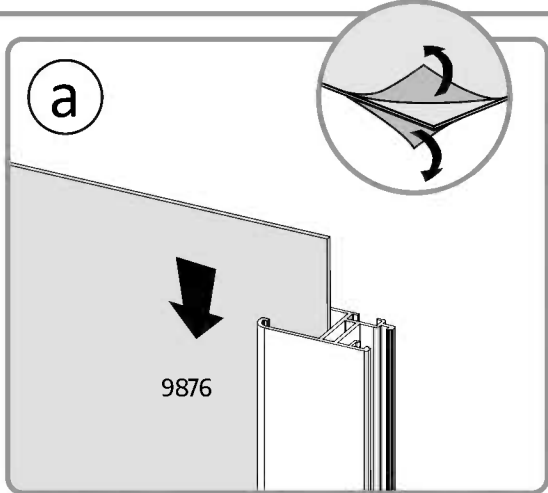
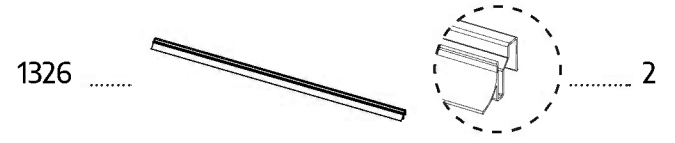
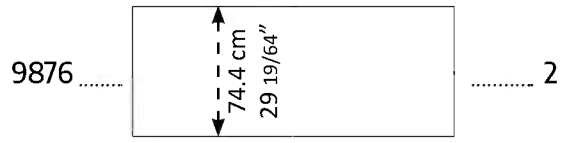
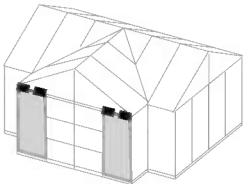

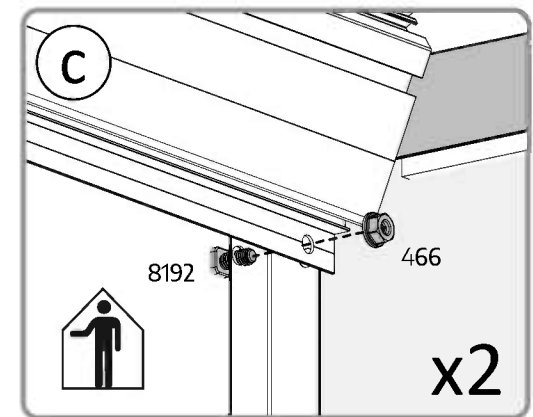
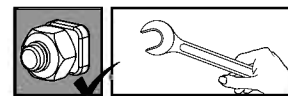
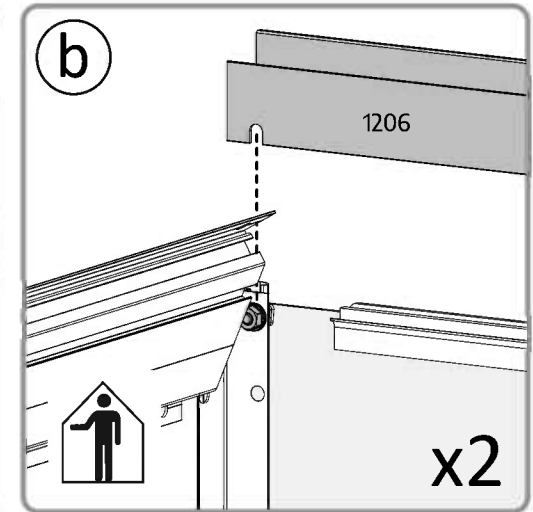
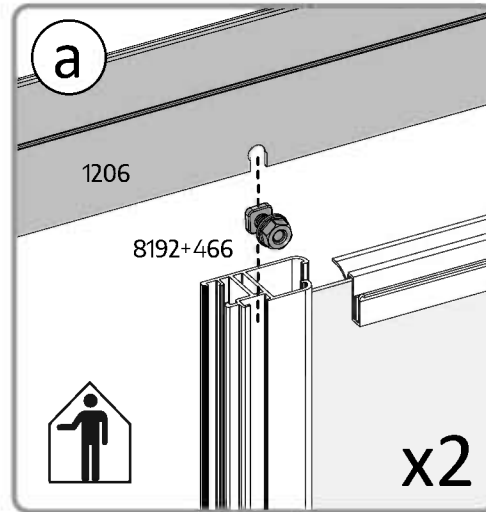
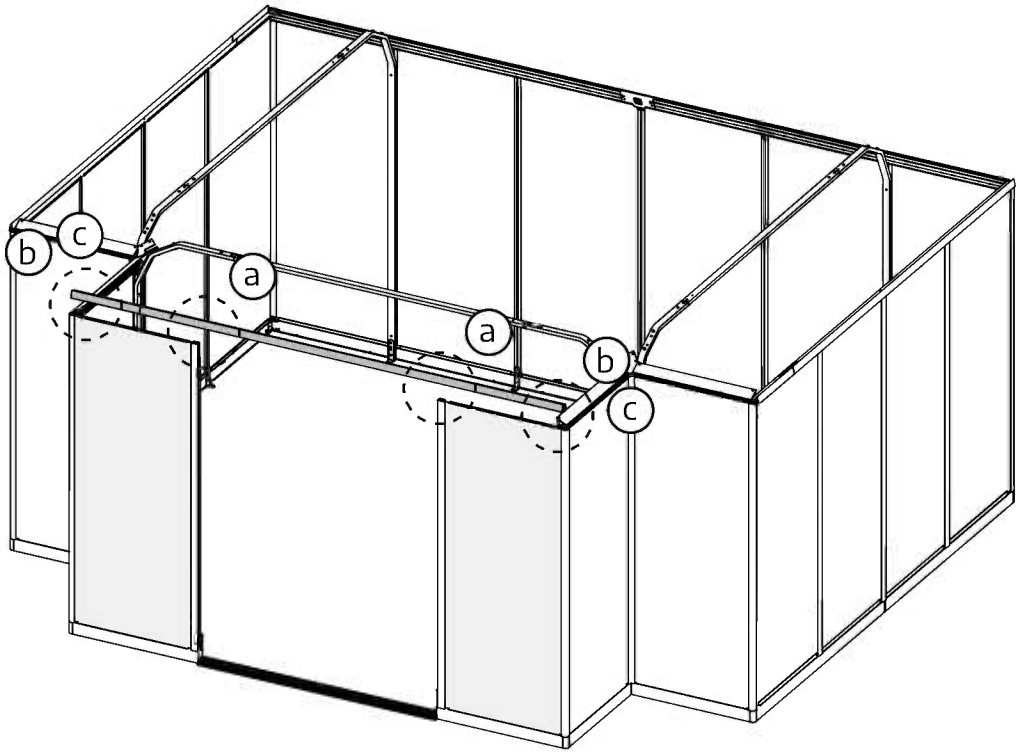
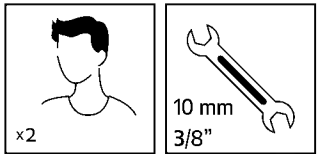
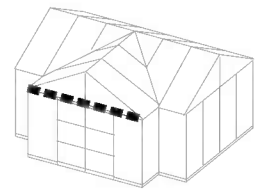

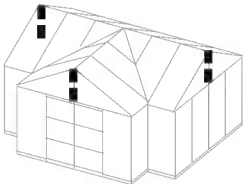

9902 3

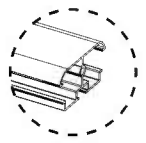

8192 3



466 3

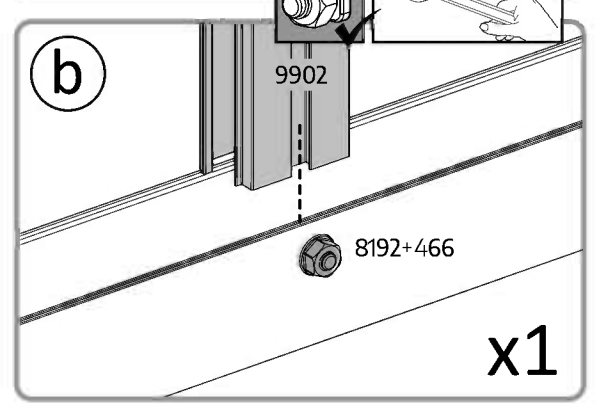
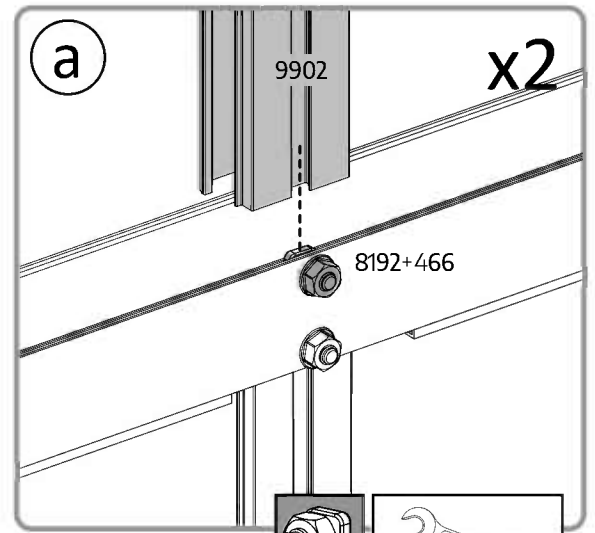
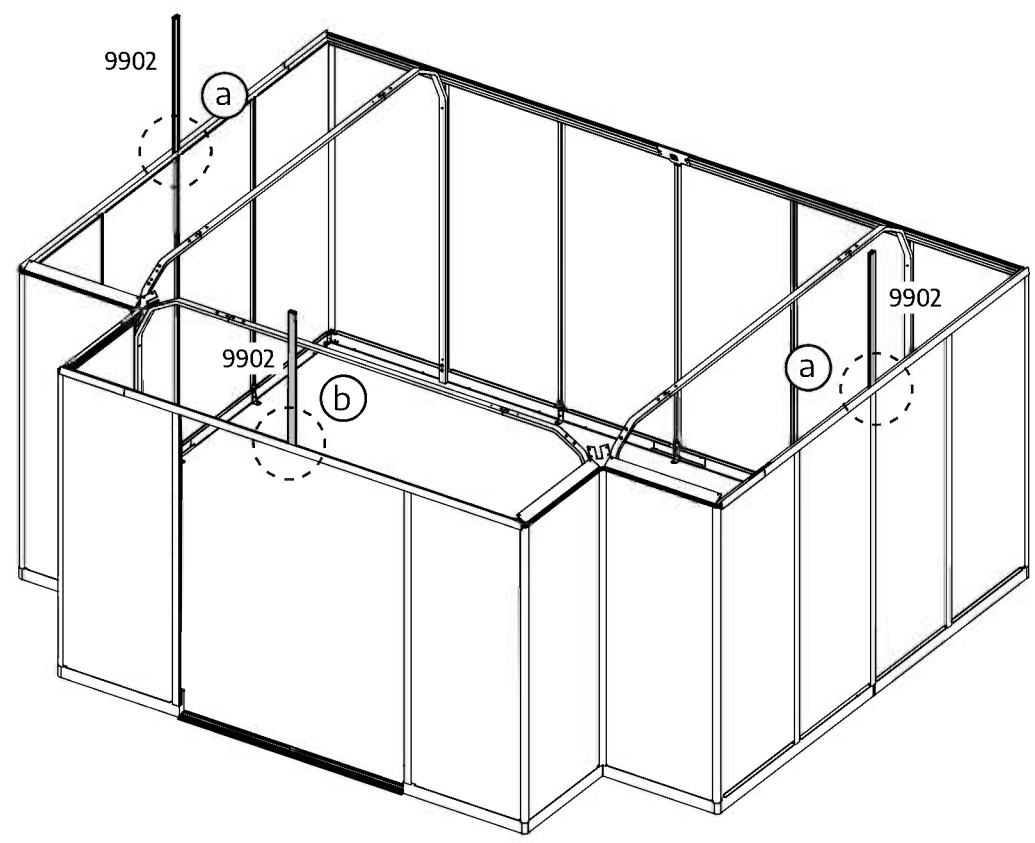
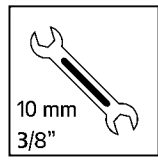

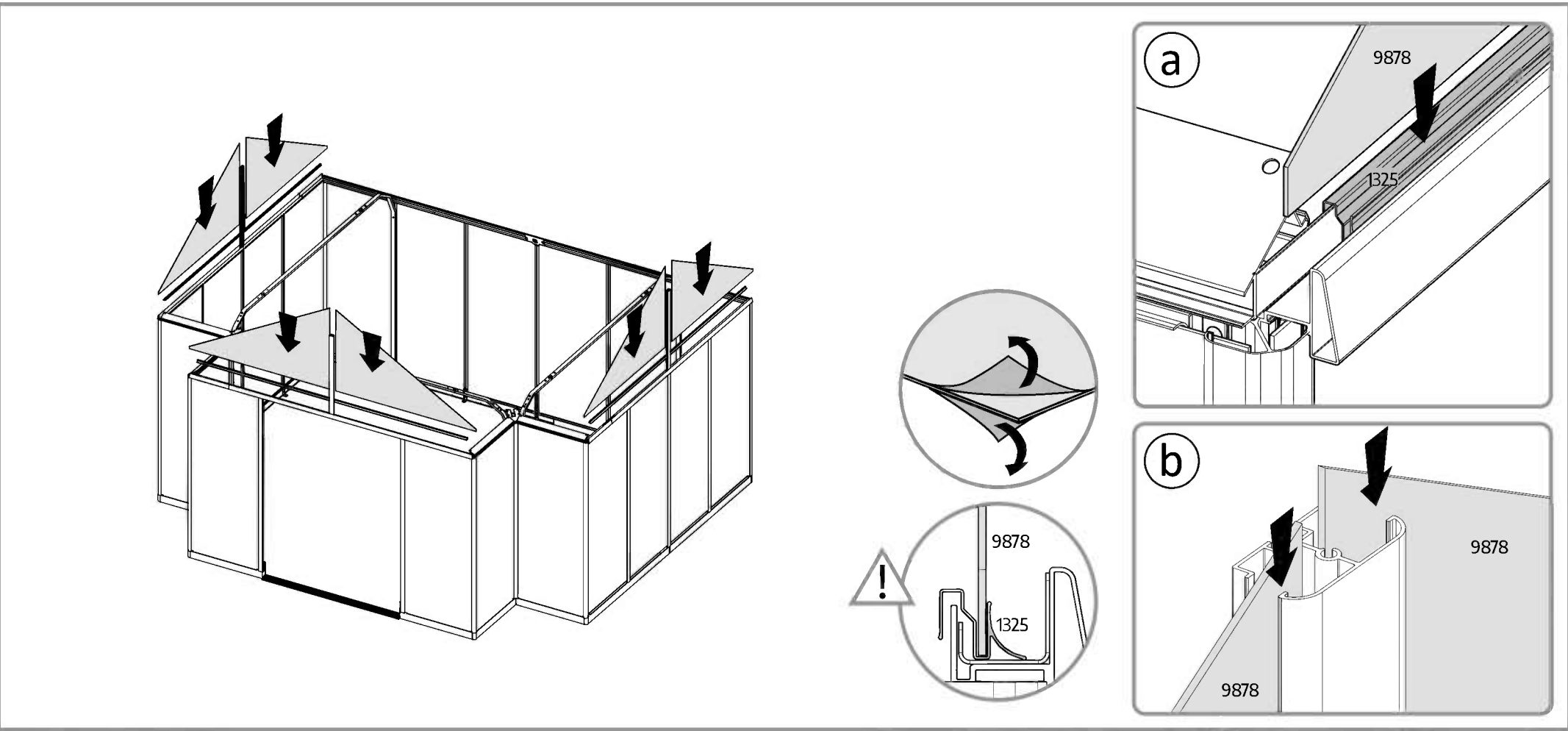
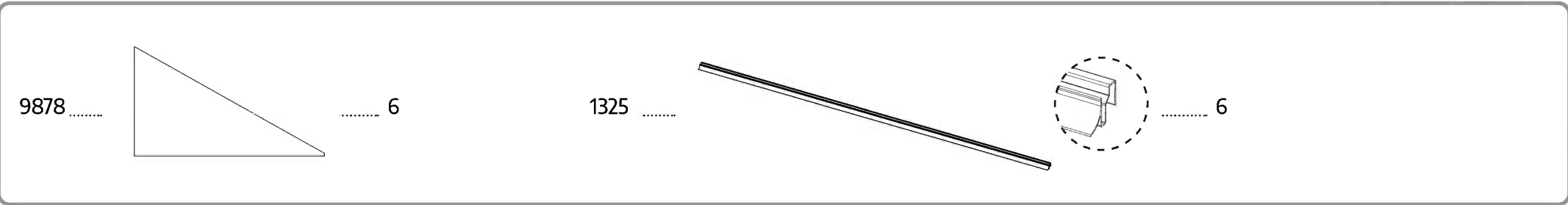
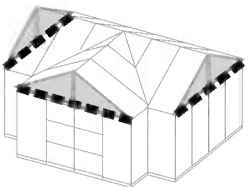

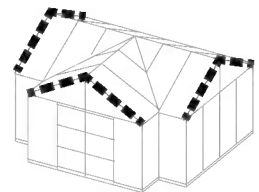

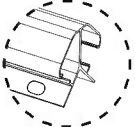
9896  6

8192  6

466  6

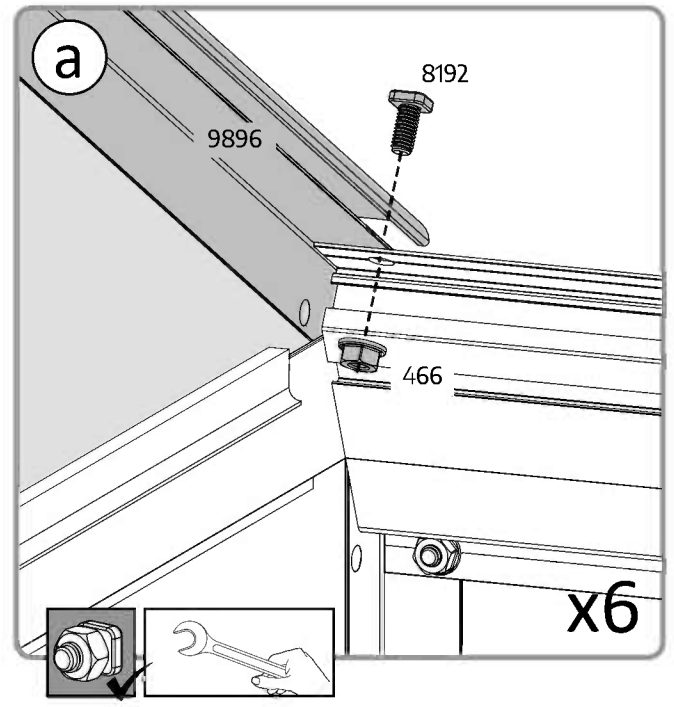
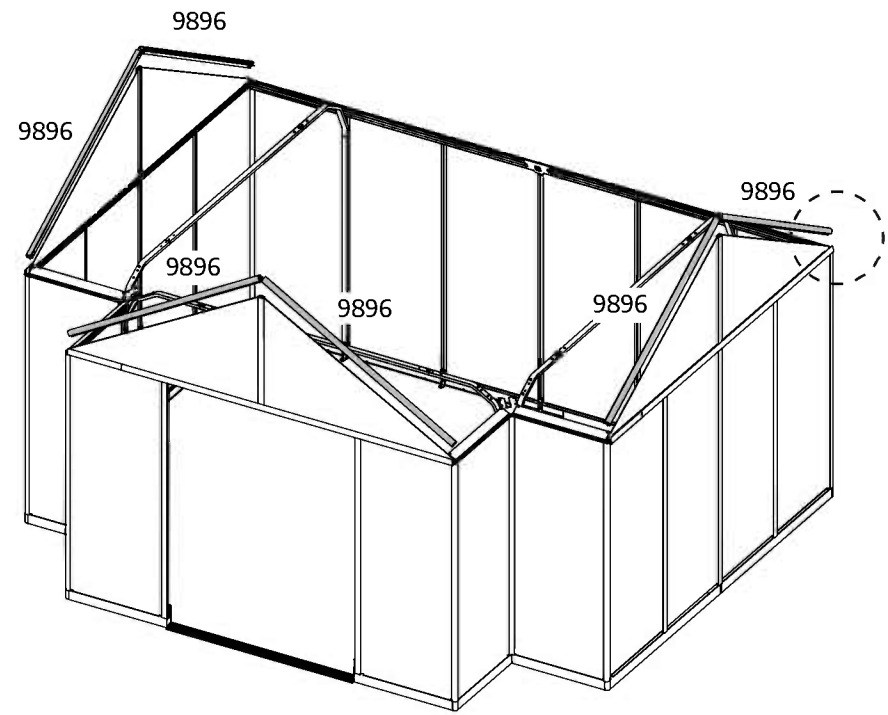
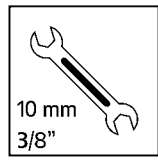

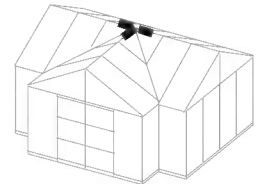

- 9965 2
- 9964 1
- 9967 1
- 7682 1
- 425 2
- 8192 1
- 466 2

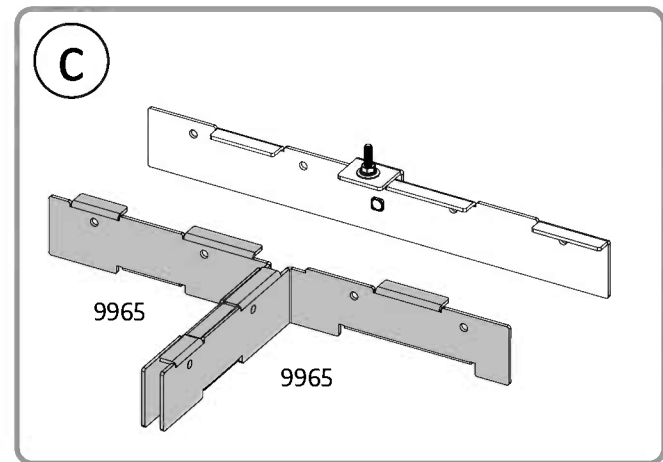
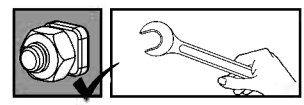
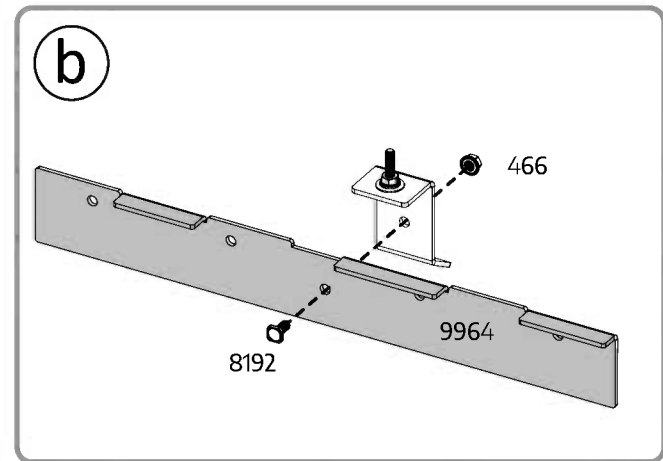
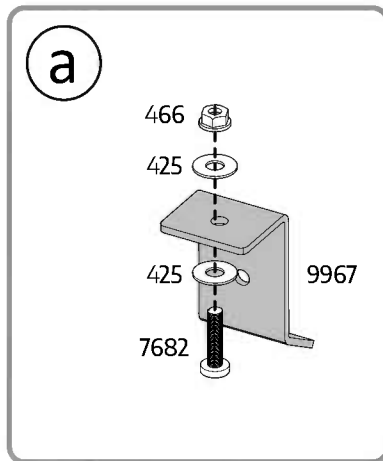
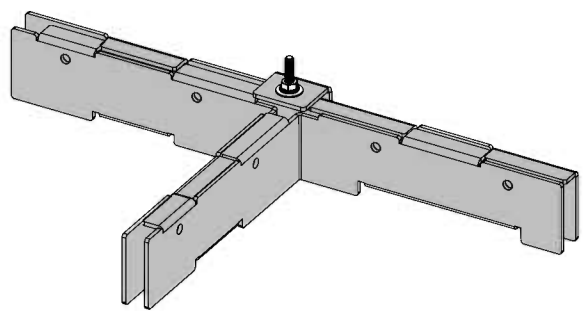
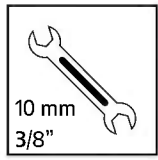

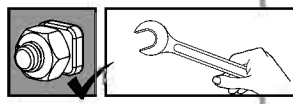
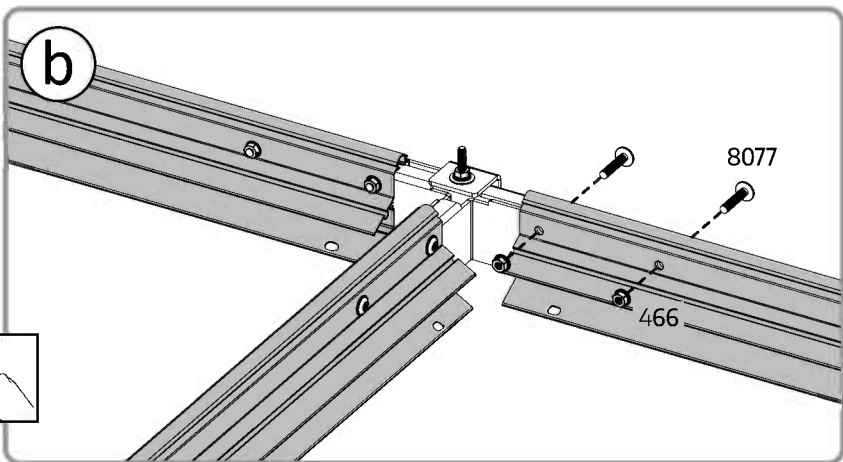
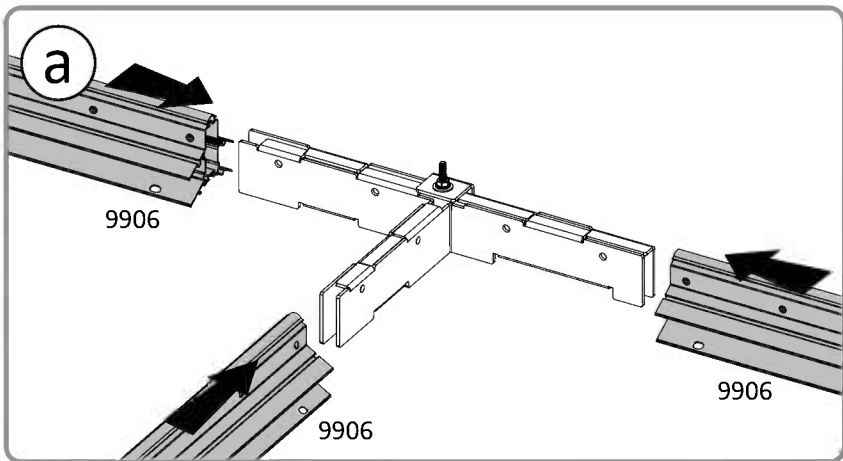
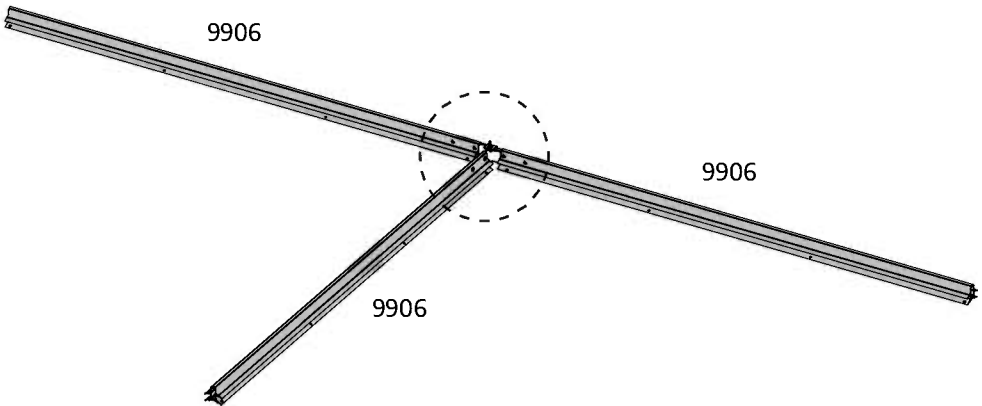
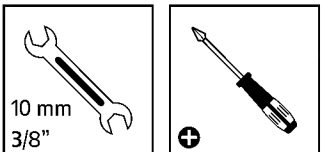
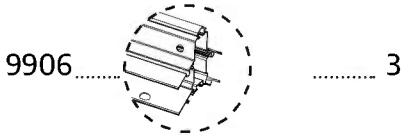
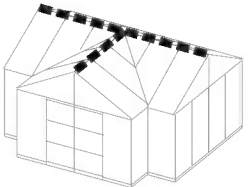

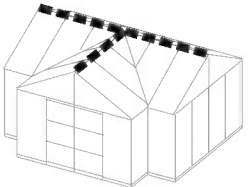

8192 13



466 13

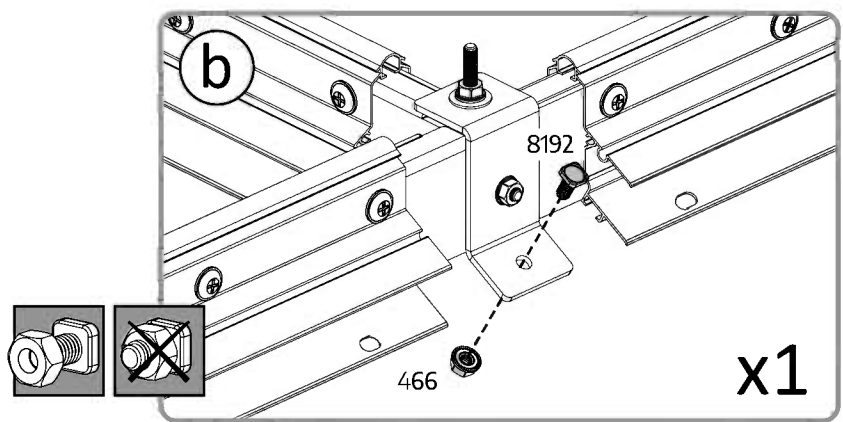
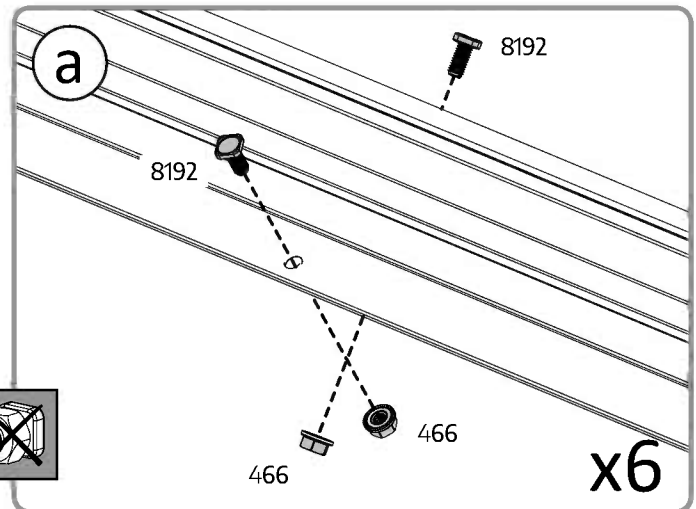
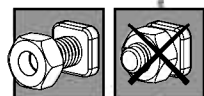
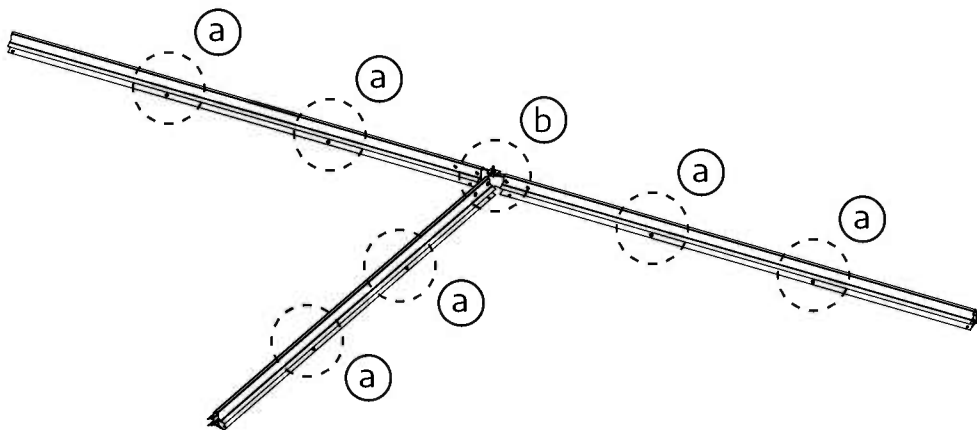

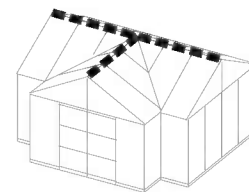

8192  15 466  6

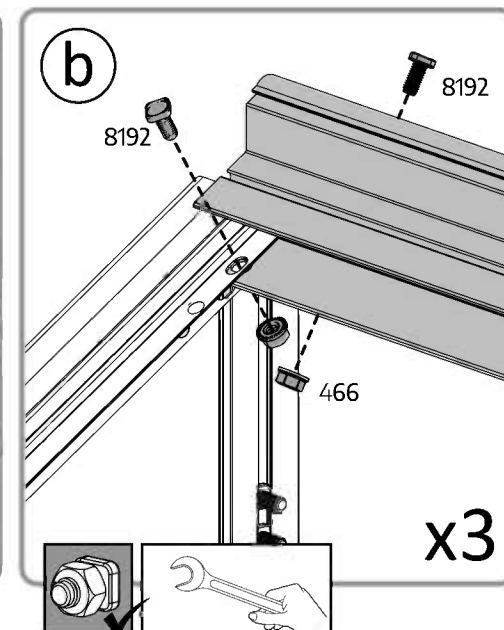
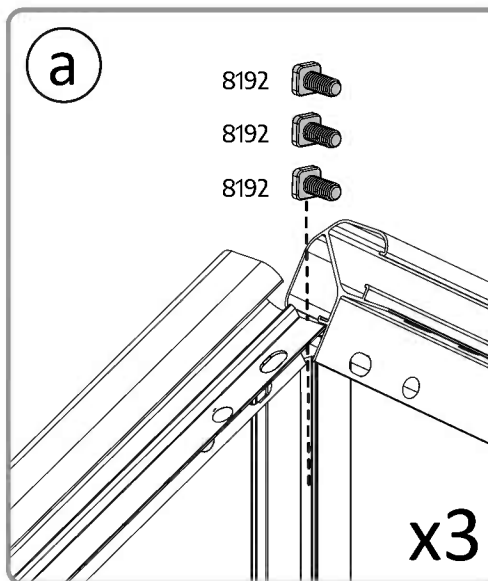
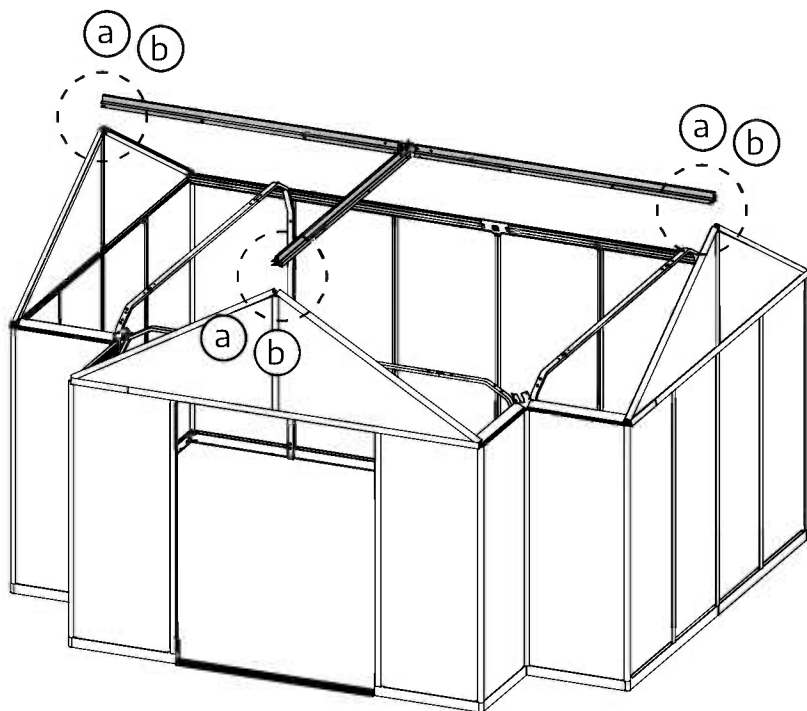
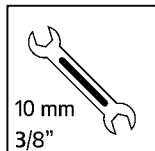
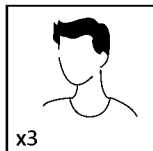
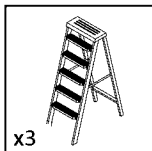

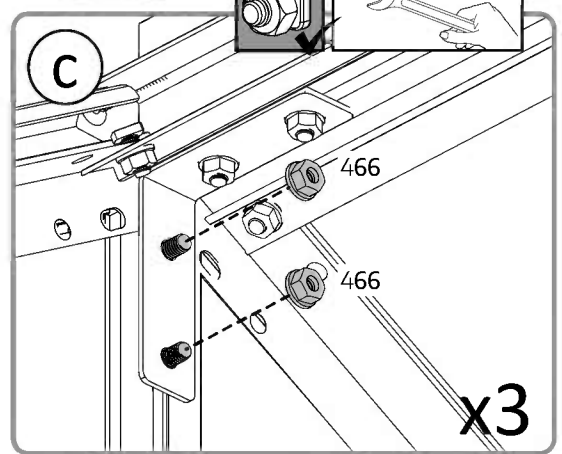
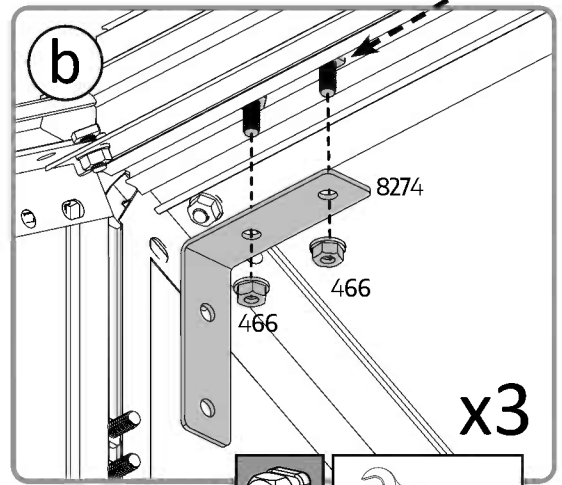
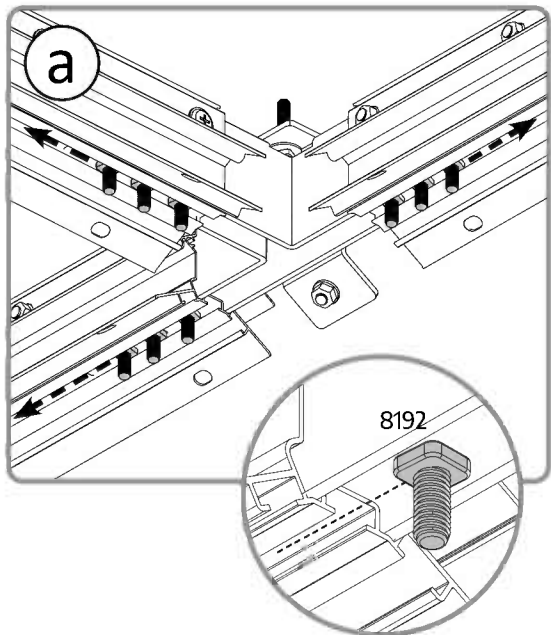
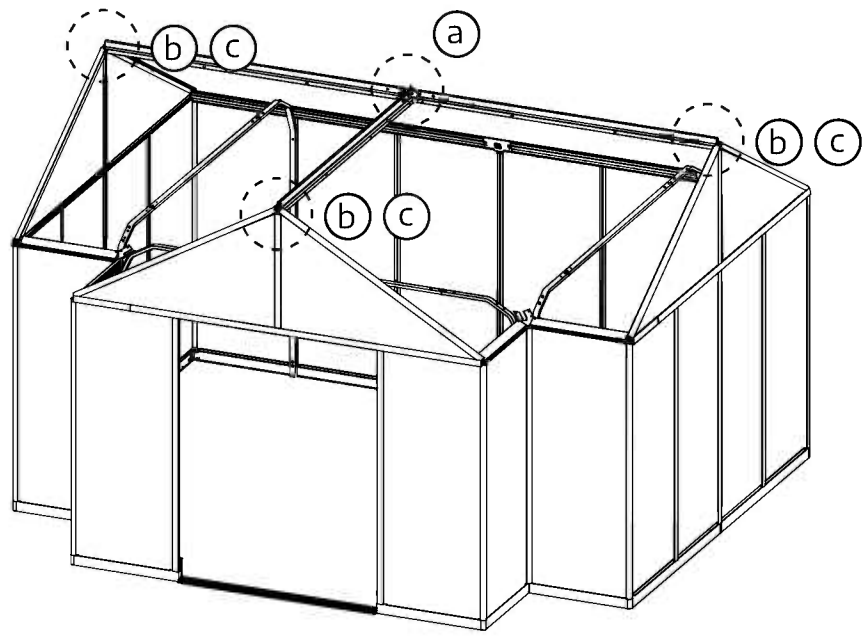
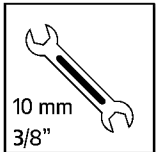
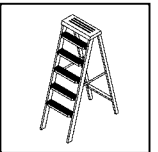
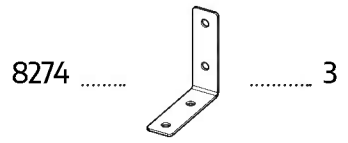
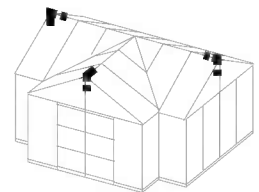

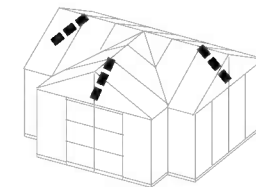

9875 3

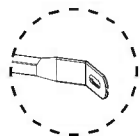

466 6

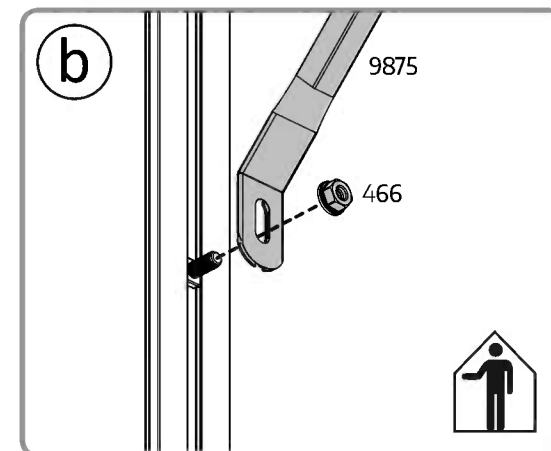
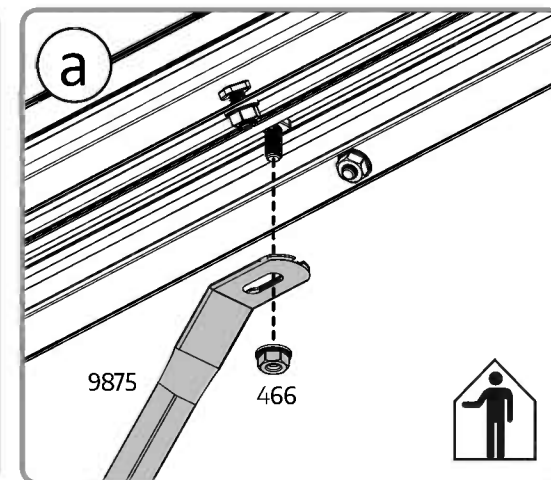
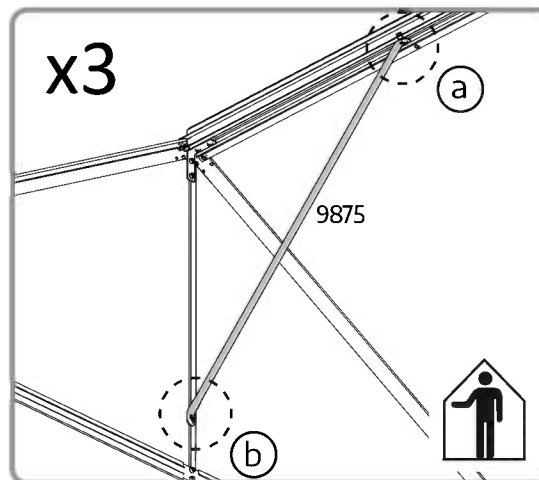
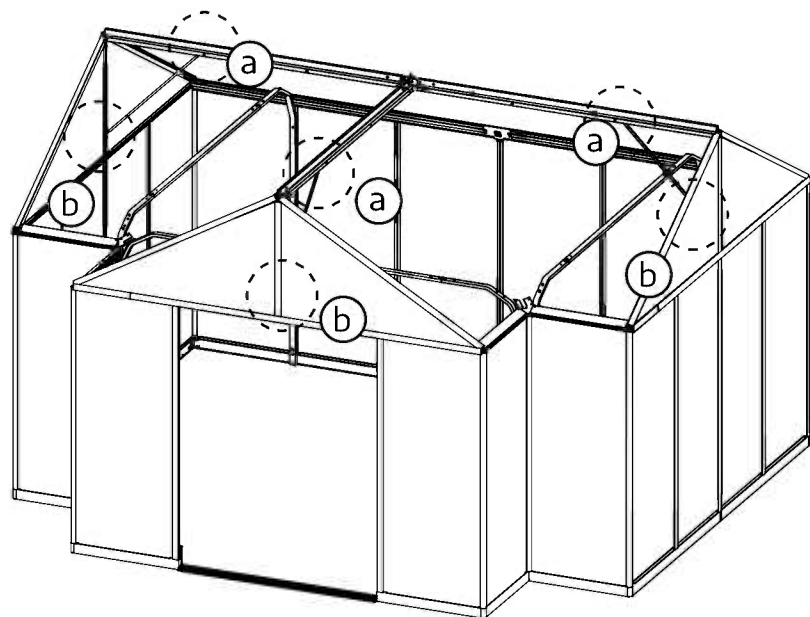
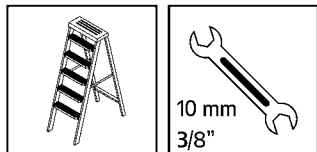

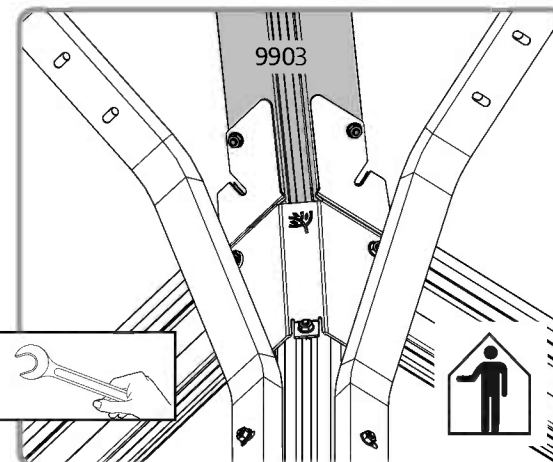
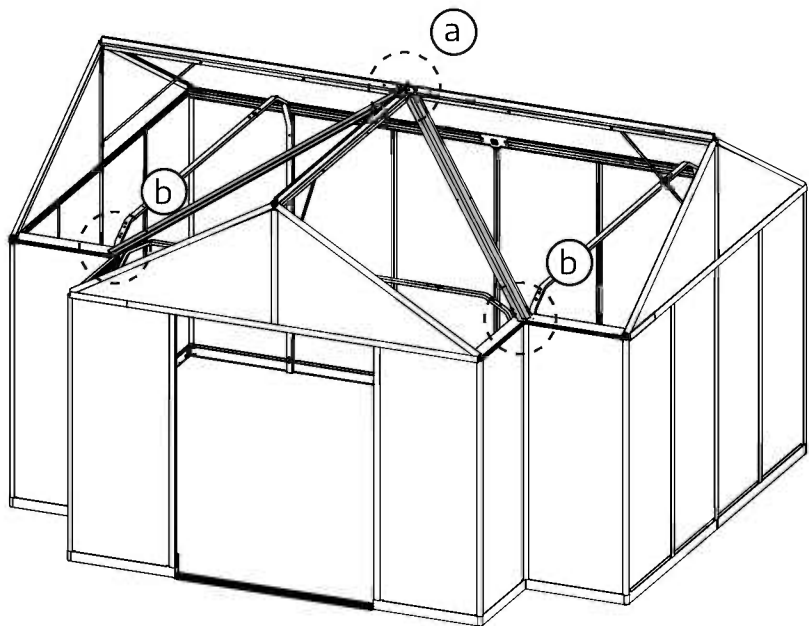
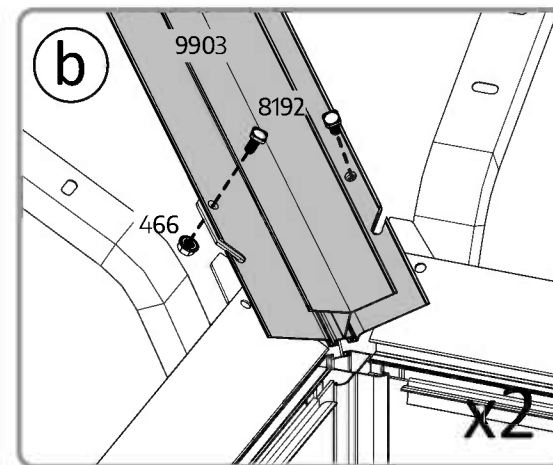
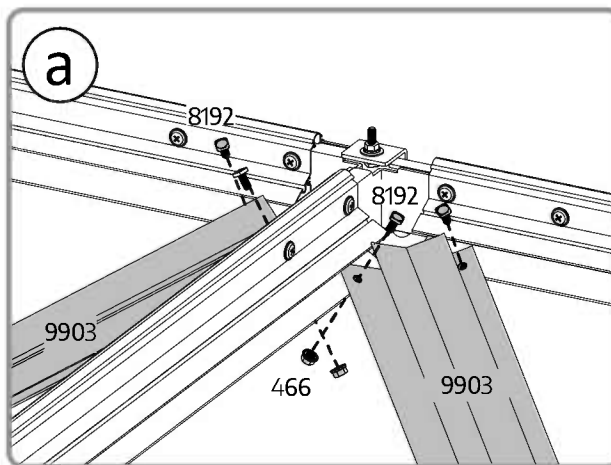
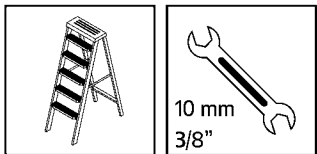
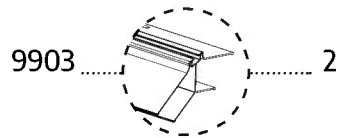
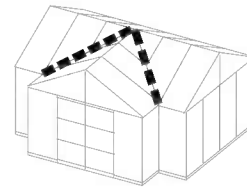



Make sure that all the profiles are extended equally as shown in the close-up drawing.

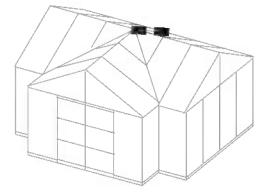

9897 1

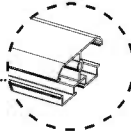

8192 3

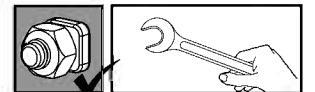
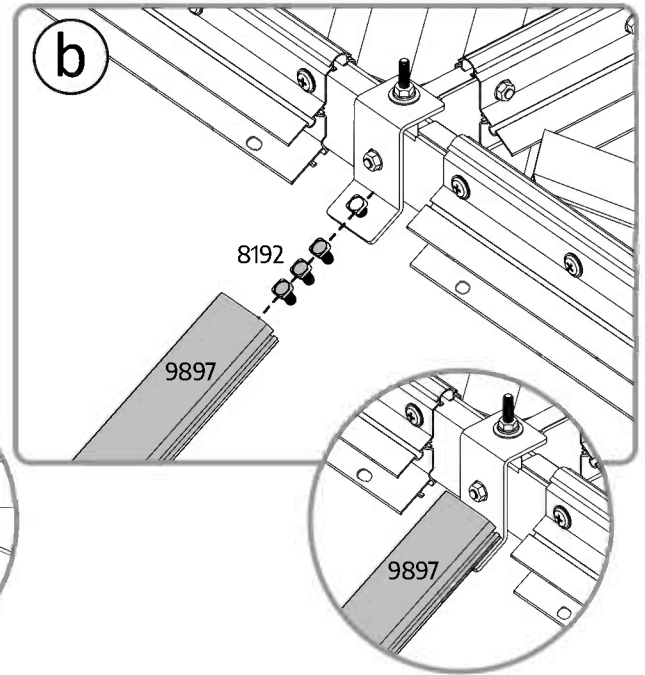
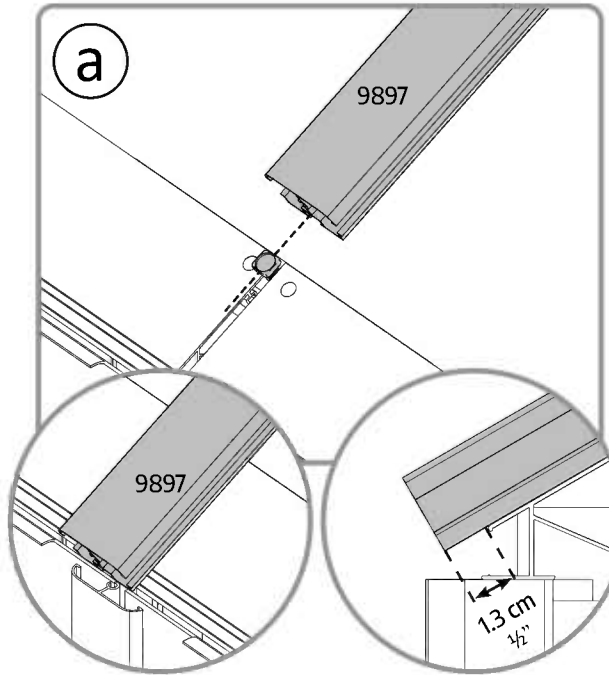
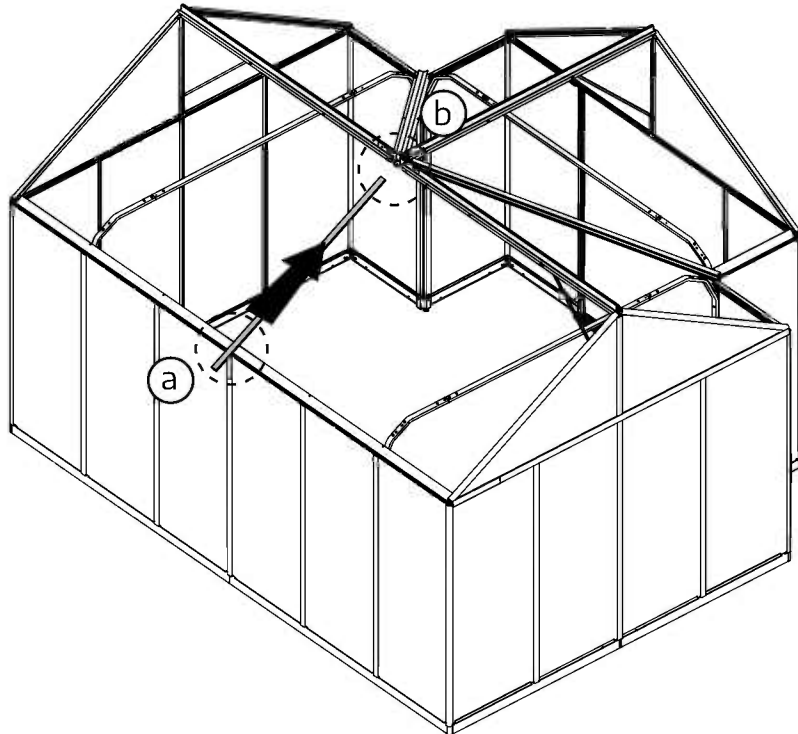
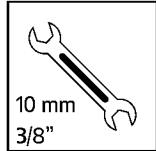



Make sure that all the profiles are extended equally as shown in the close-up drawing.

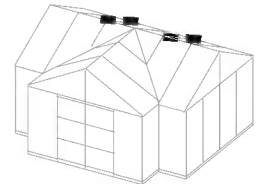

9897 2

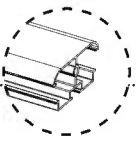



8192 6

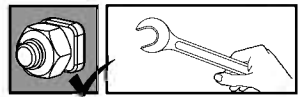
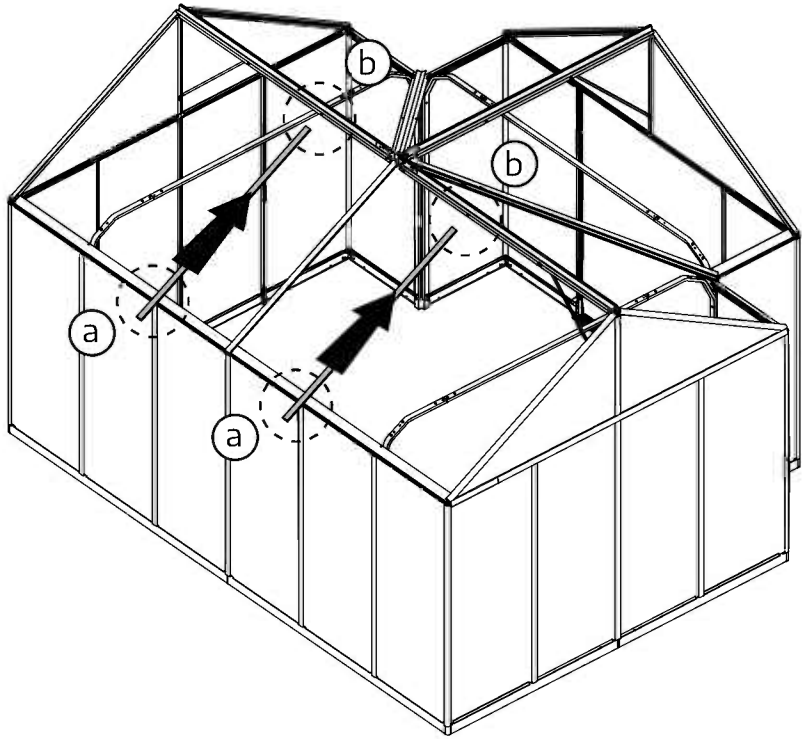
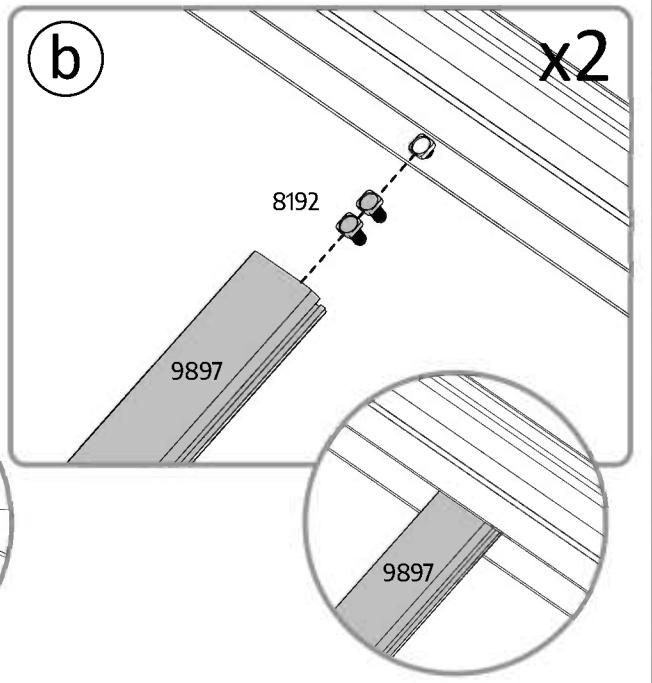
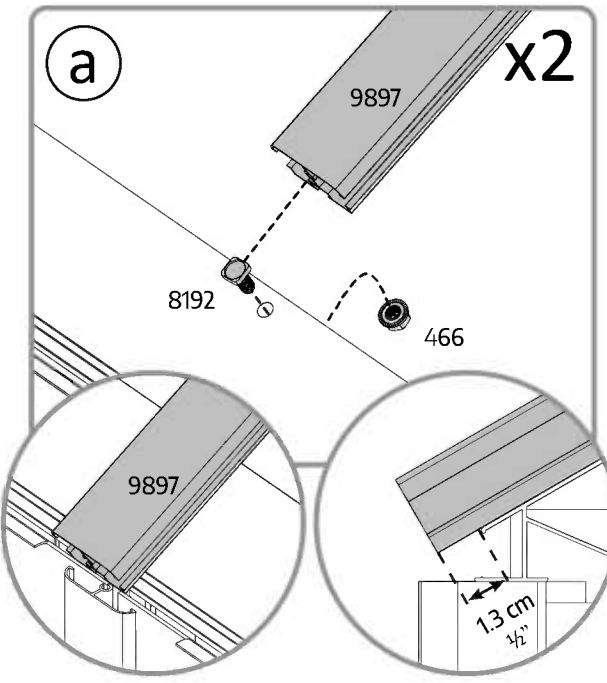
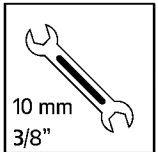

466 2

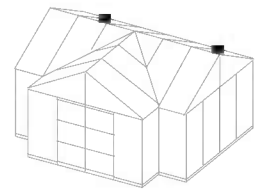



7284  4 466  4

10 mm
3/8"

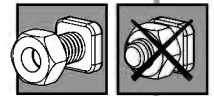
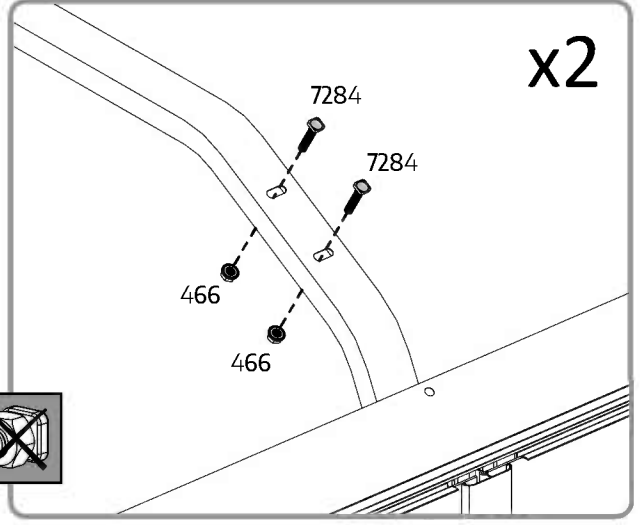
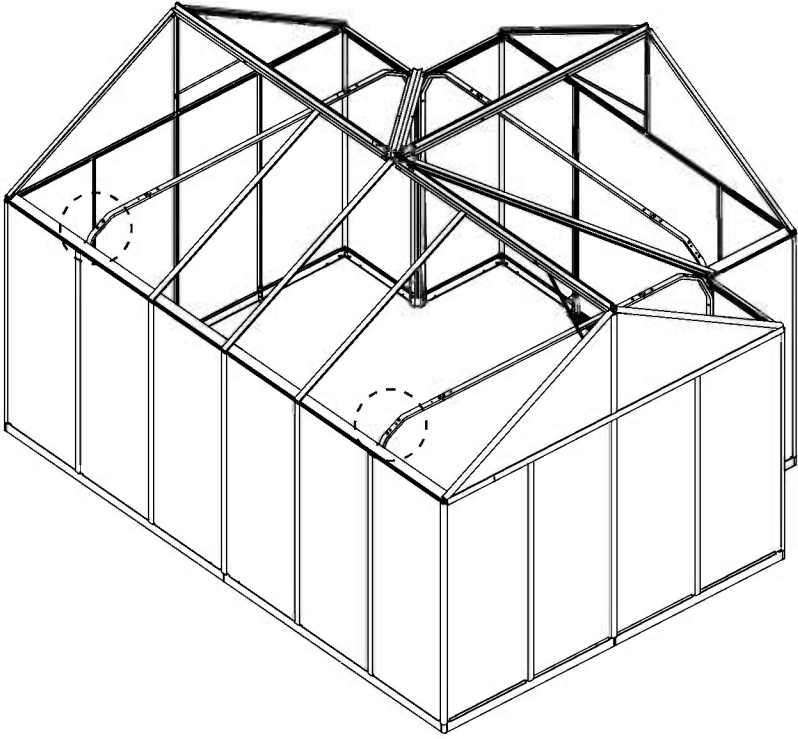



Make sure that all the profiles are extended equally as shown in the close-up drawing.

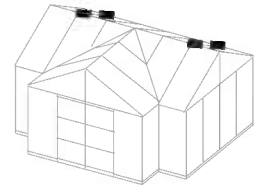

9897 2

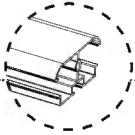

8192 6



466 2

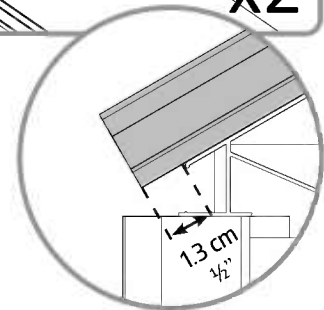
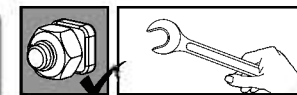
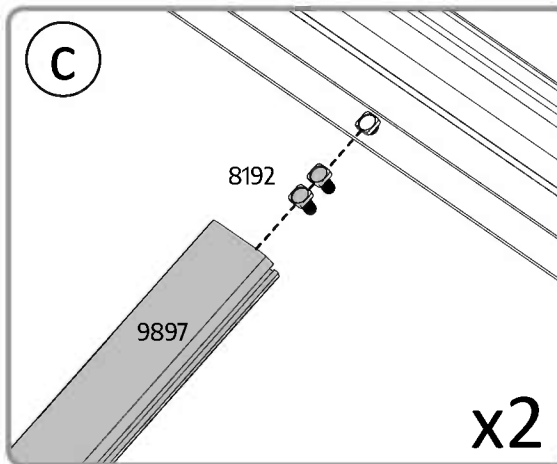
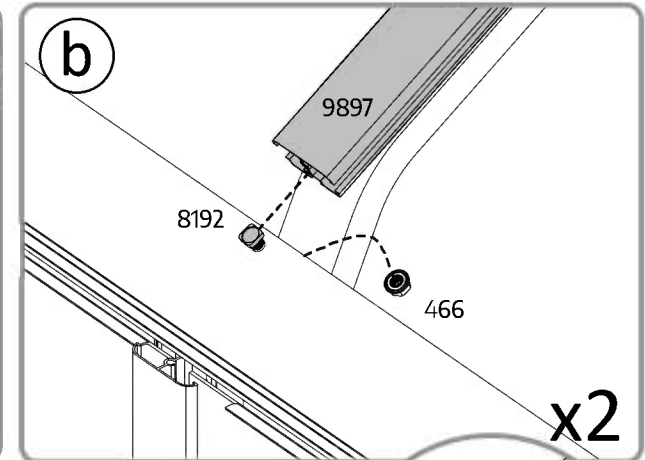
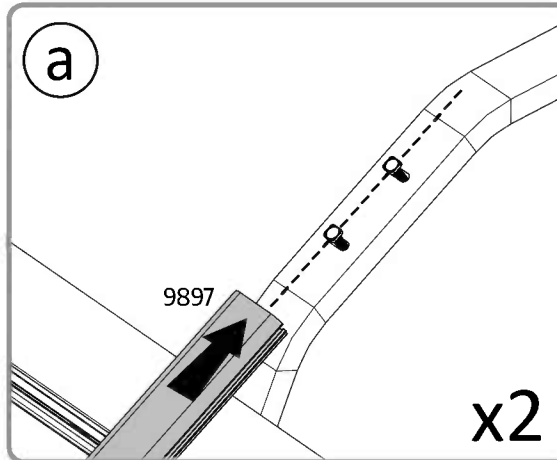
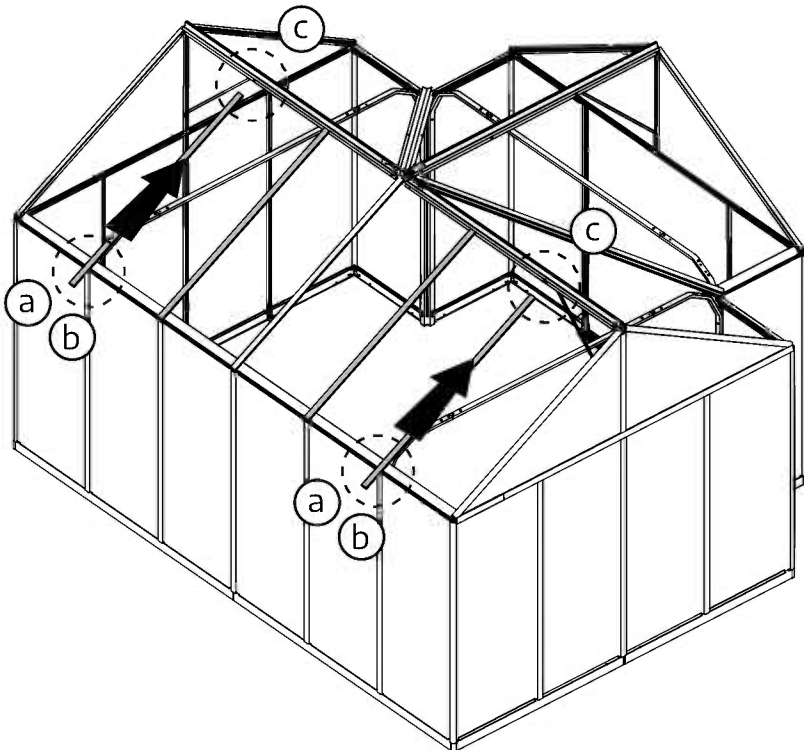
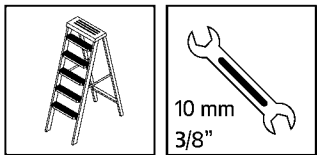

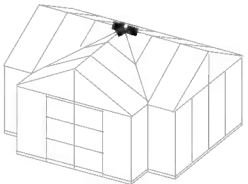

- 9830 1
- 4024 1
- 466 1
- 5001 1

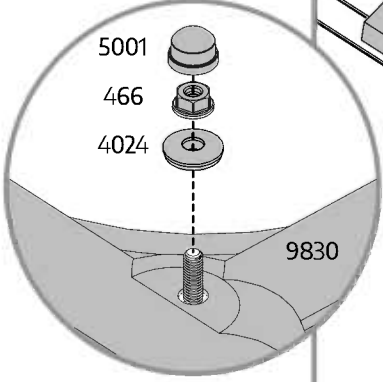
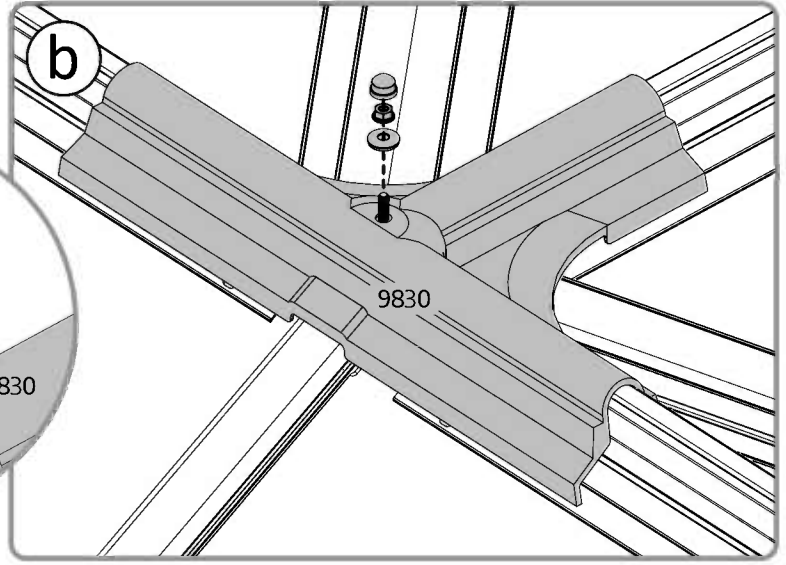
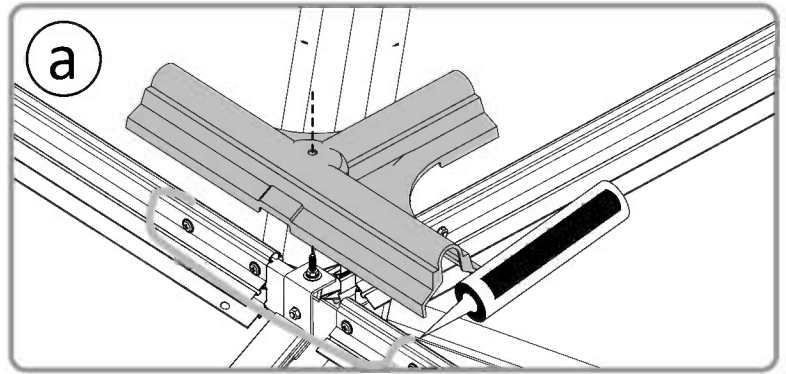
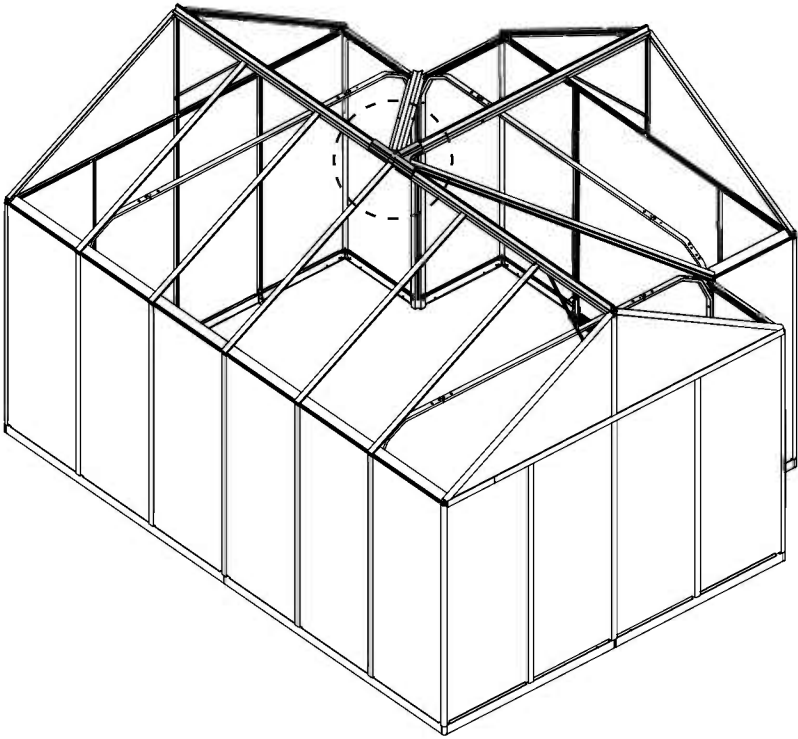
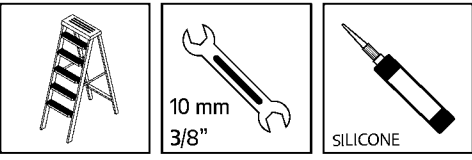



All panels with the stamped words "THIS SIDE OUT" must be facing out to create full UV protection.
Remove plastic sticker as panels are locked in place.

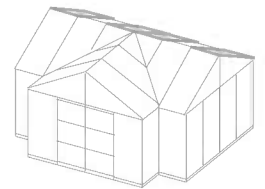

9879



..... 4

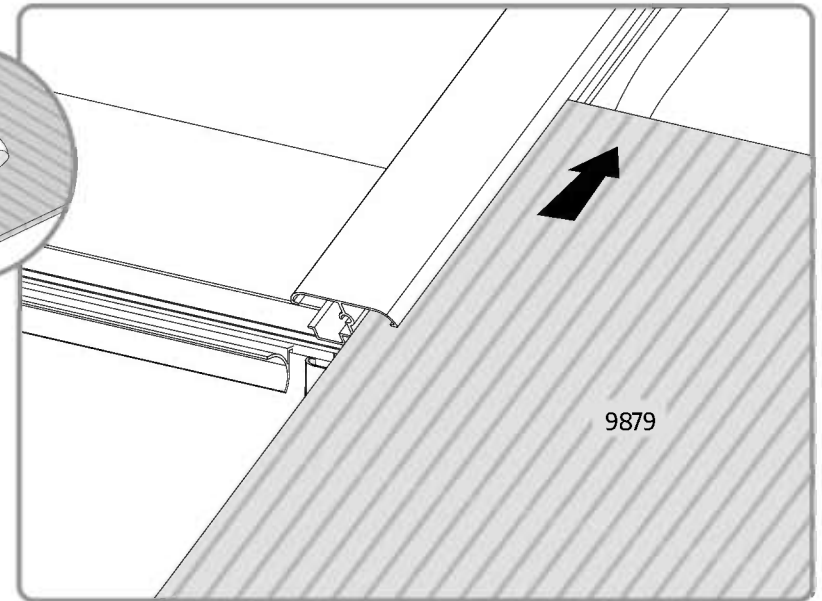
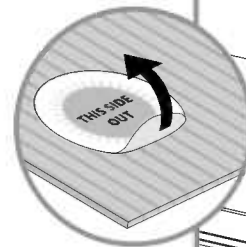
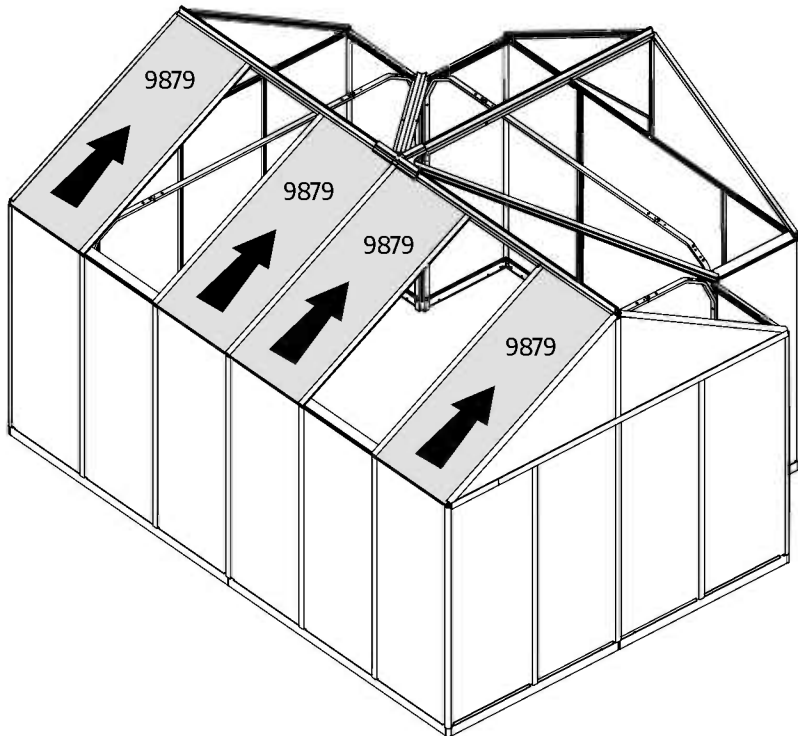

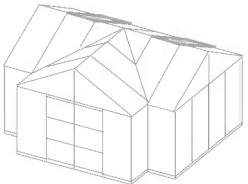

9972  2

7894  5

4008  5

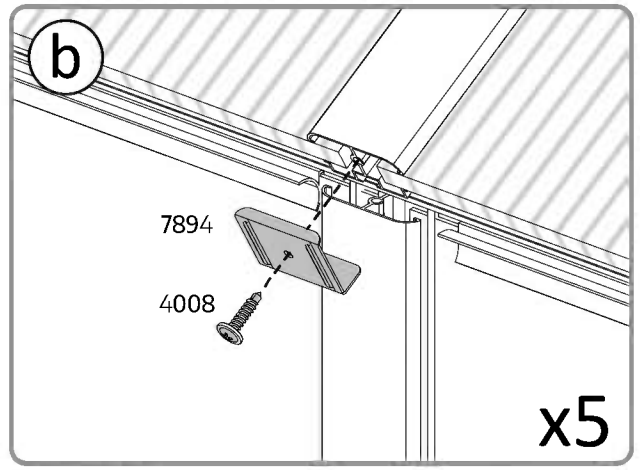
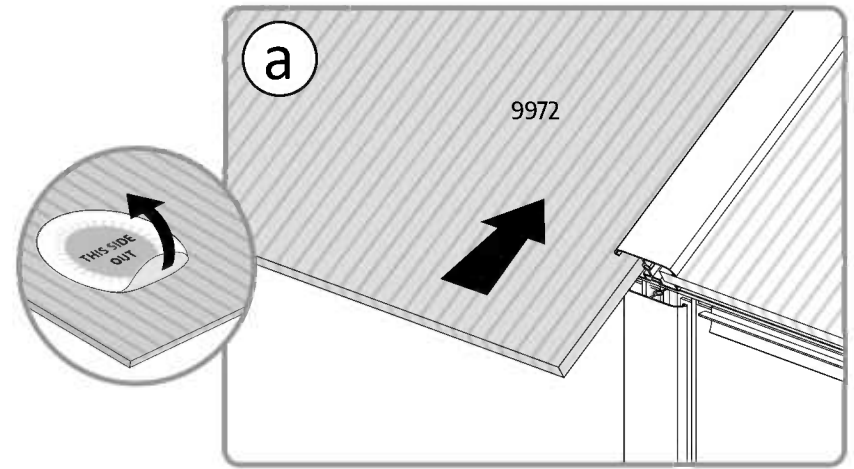
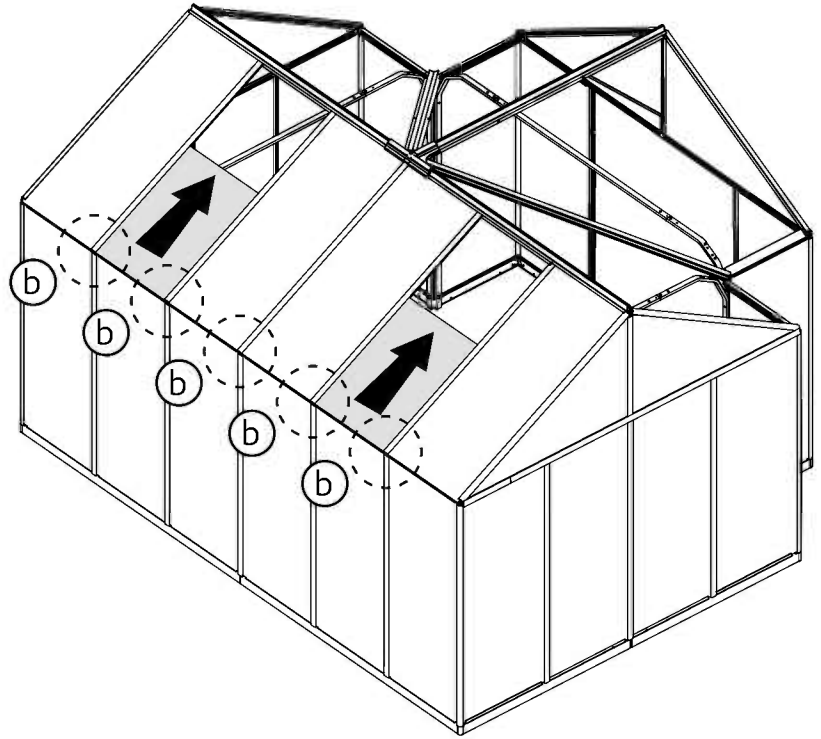

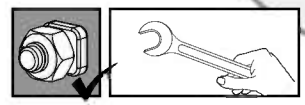
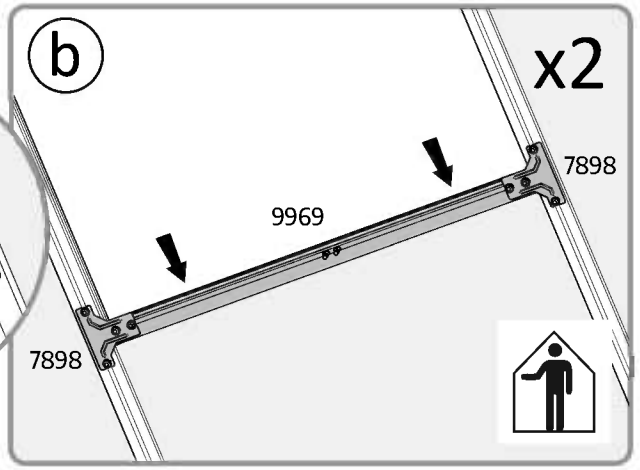
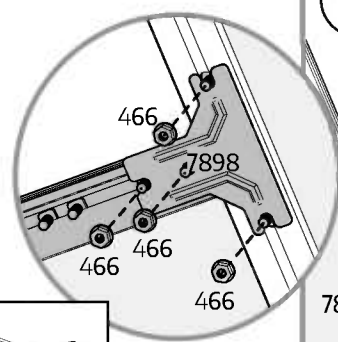
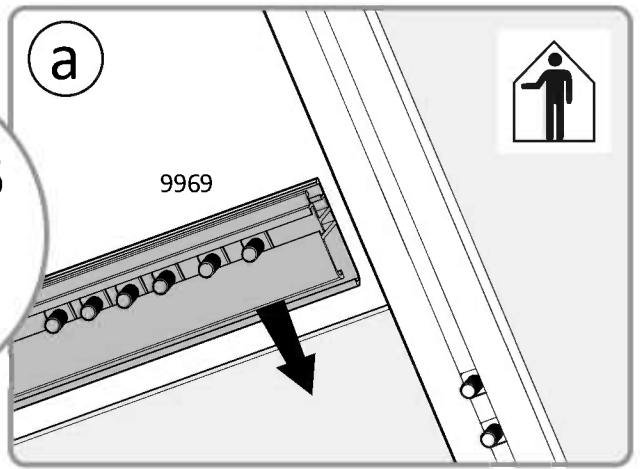
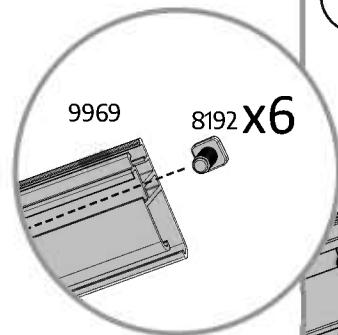
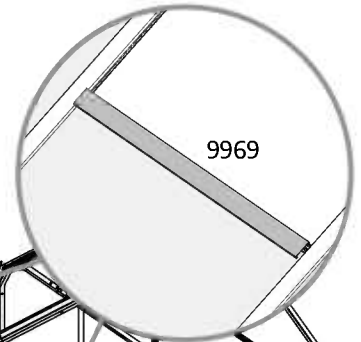
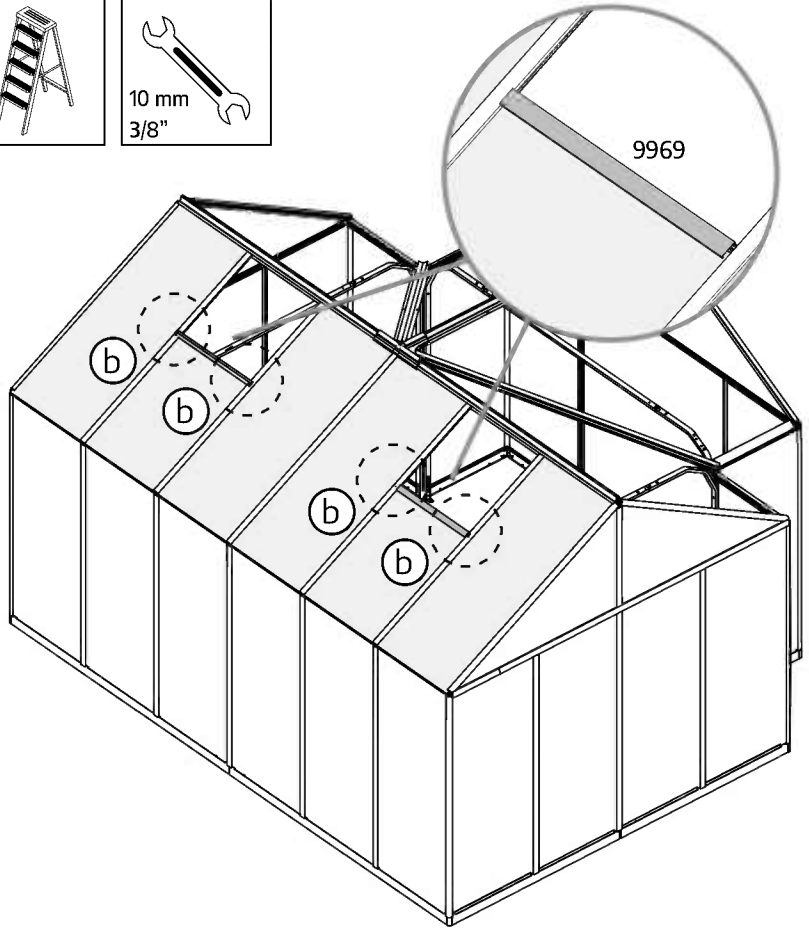
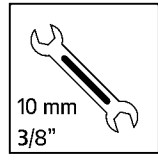
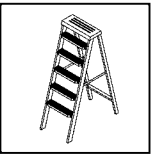
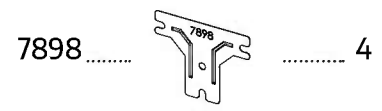
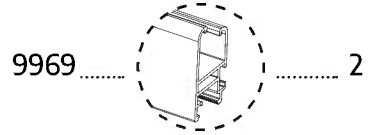
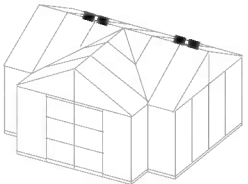



Please use dry cloth to wipe the panel prior to attaching the sealing tape to the panels' edges.

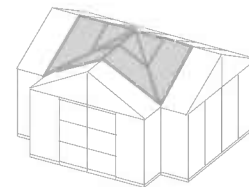

9881.....



..... 2

9883.....



..... 2

9882.....



..... 2

9884.....



..... 2

8293.....

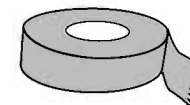

.....1

8293

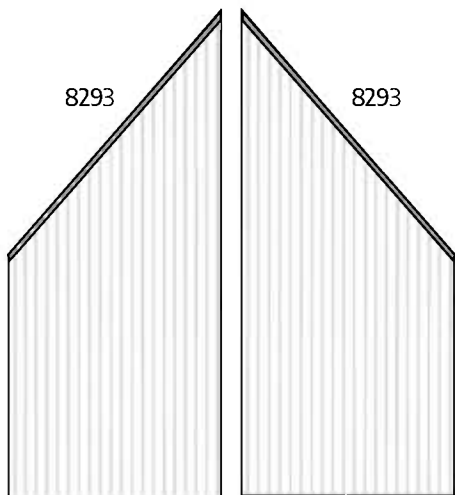

8293

8293

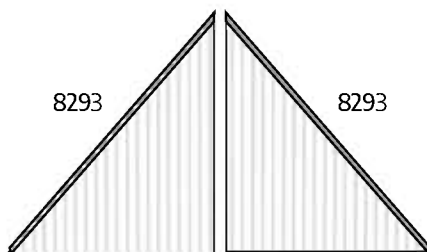

8293

a

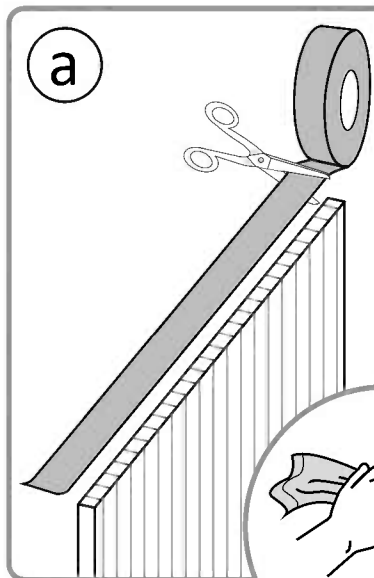

b

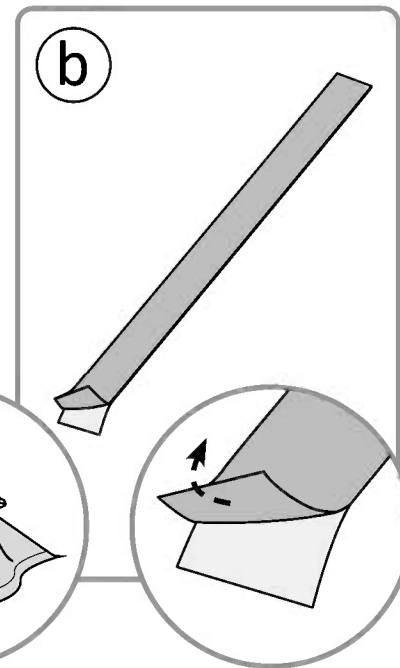

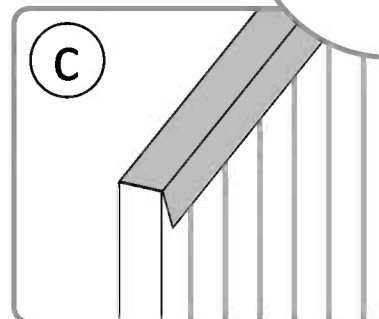

c



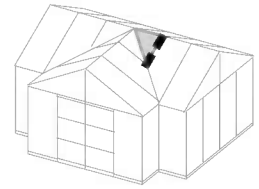

All panels with the stamped words "THIS SIDE OUT" must be facing out to create full UV protection. Remove plastic sticker as panels are locked in place.

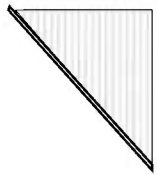
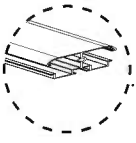

- 9883.....  1
- 9901.....  1
- 8192.....  1
- 466.....  1

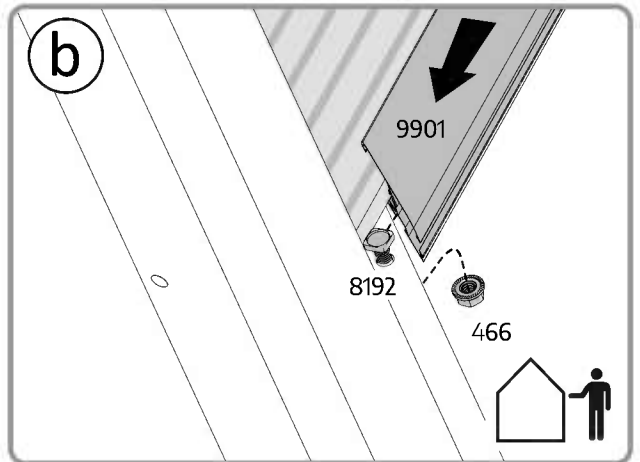
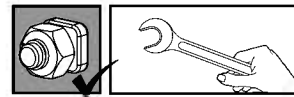
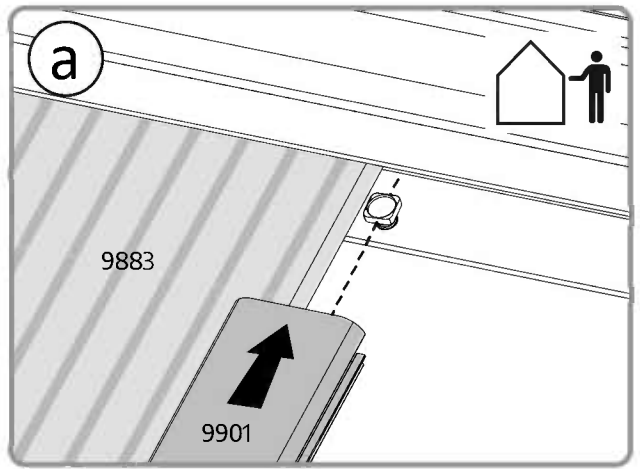
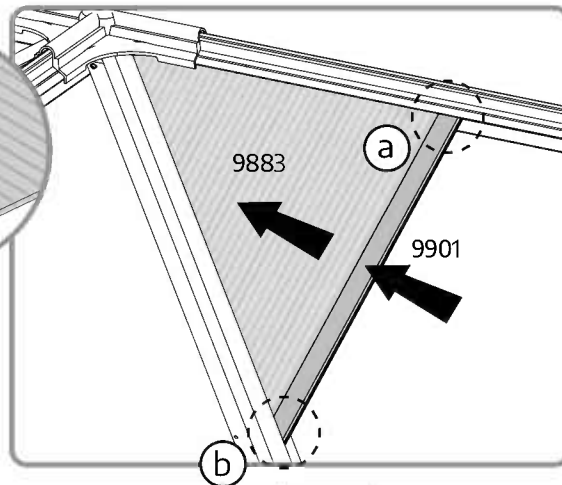
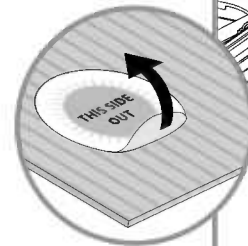
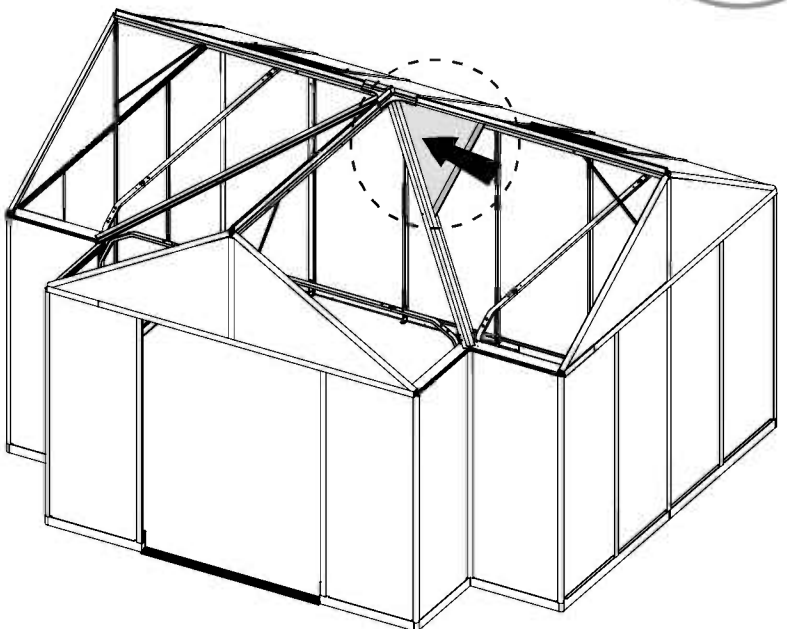
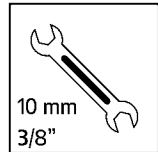
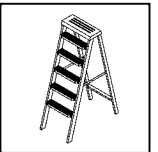

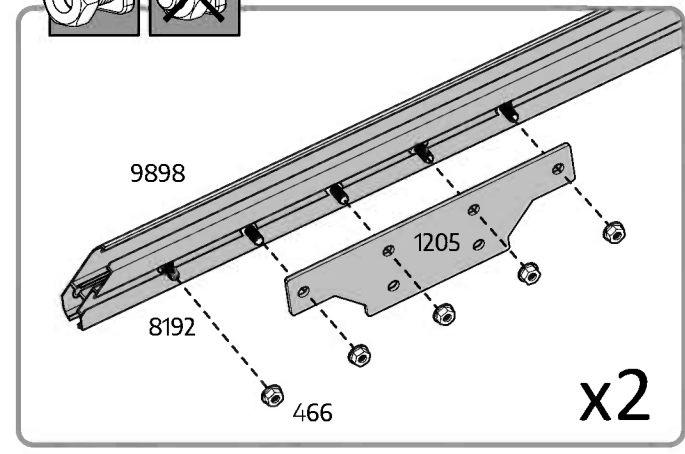
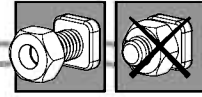
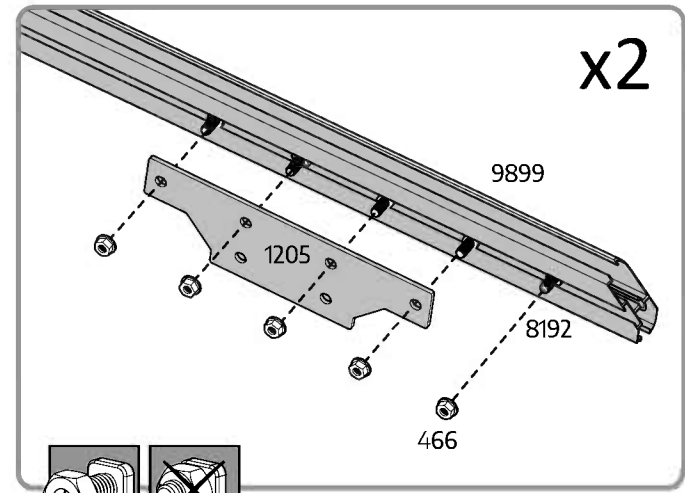
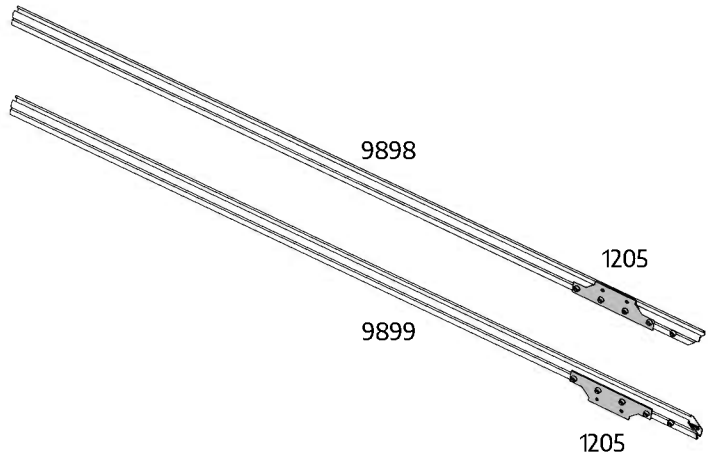
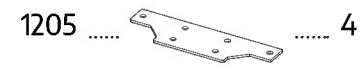
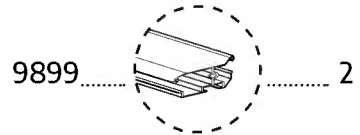
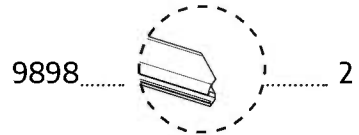
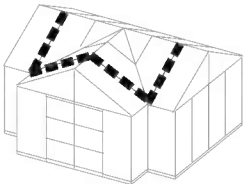

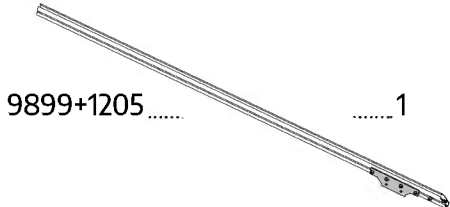
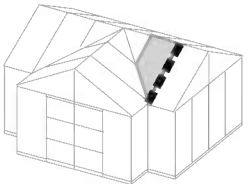

9899+1205 1



9881 1



7284 2



466 2

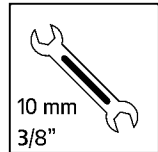
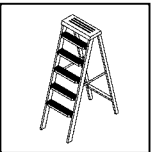

10 mm
3/8"

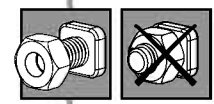
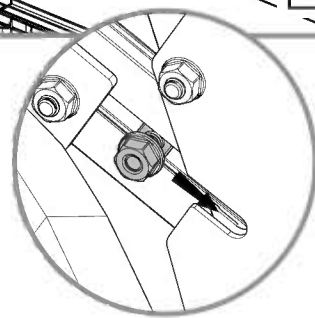
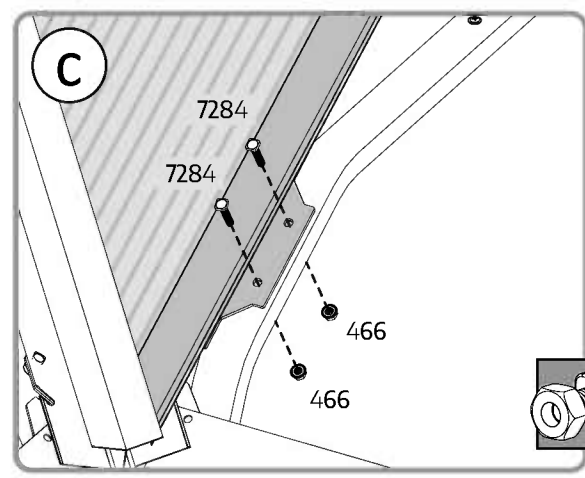
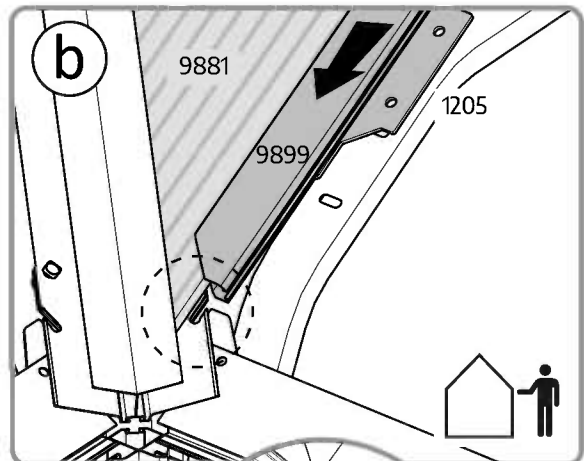
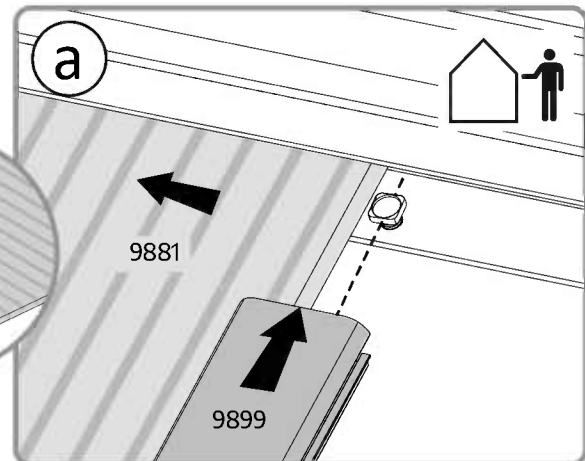
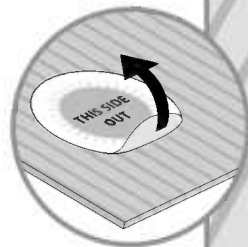
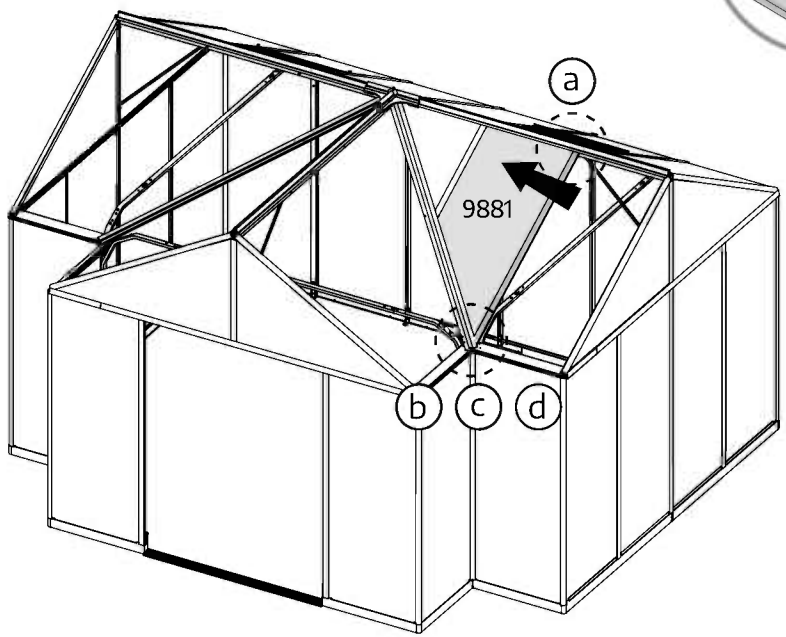



Please repeat steps 59+61.

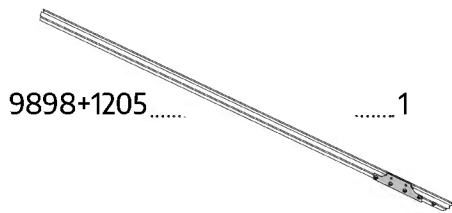
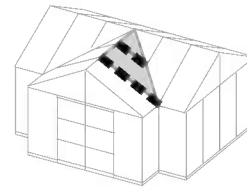

9898+1205 1



9884 2



9882 1



9900 1



7284 2



8192 1



466 3



10 mm
3/8"

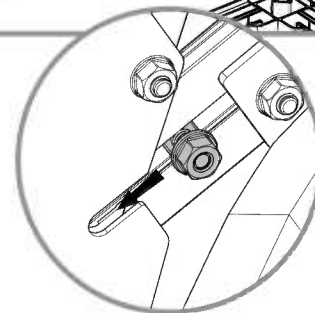
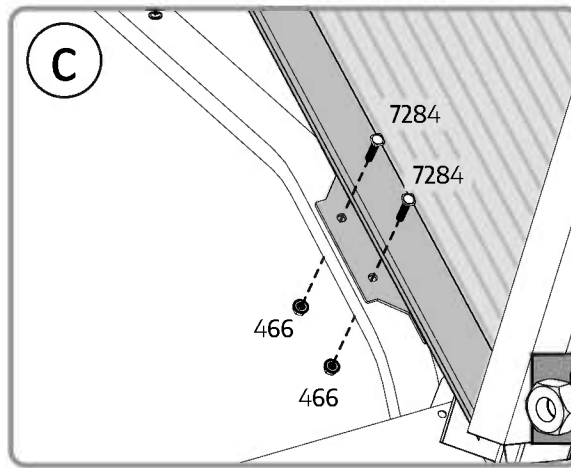
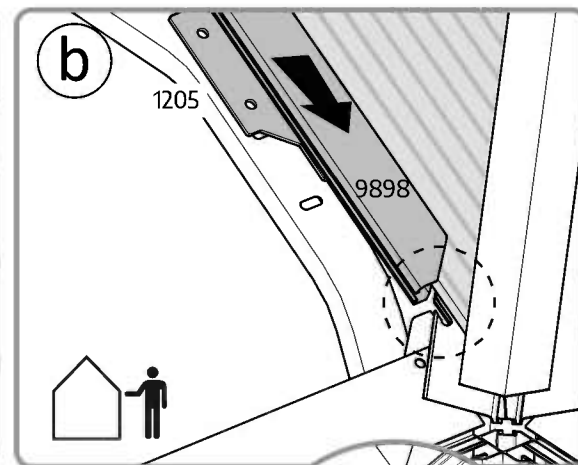
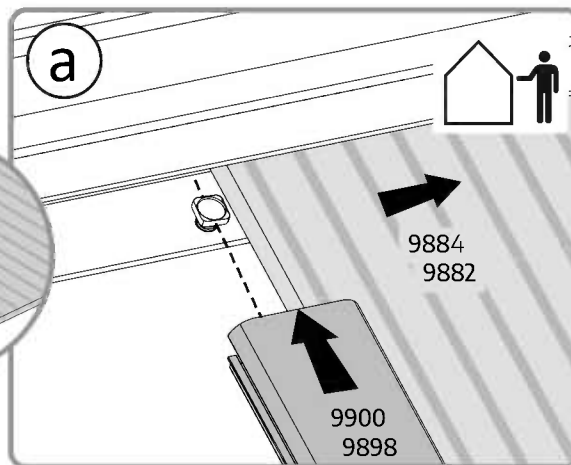
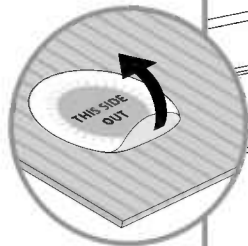
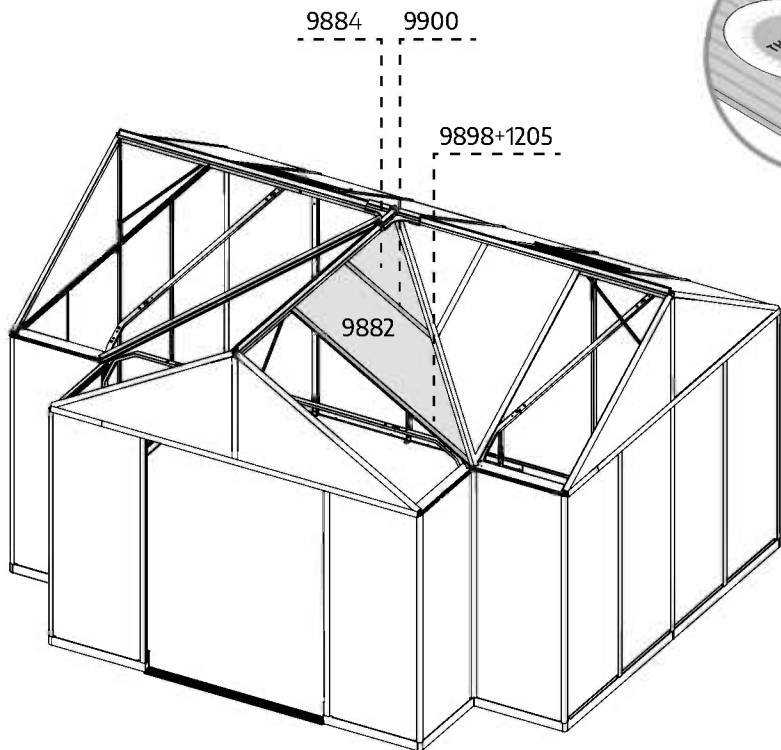



Please repeat steps 59+61.

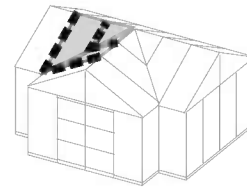

- | | | | | | | | | | | | | | | |
|-----------|--|---------|-----------|--|---------|----------------|--|---------|-----------|--|---------|-----------|--|---------|
| 9881..... | | 1 | 9883..... | | 1 | 9898+1205..... | | 1 | 9900..... | | 1 | 8192..... | | 2 |
| 9882..... | | 1 | 9884..... | | 1 | 9899+1205..... | | 1 | 9901..... | | 1 | 7284..... | | 4 |
| | | | | | | | | | | | | 466..... | | 6 |

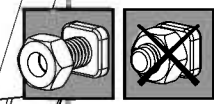
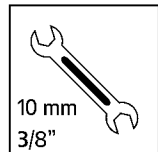
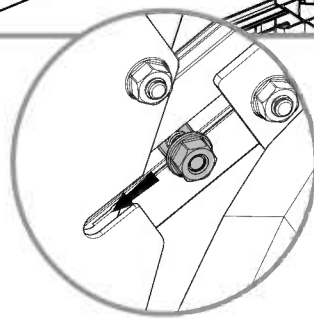
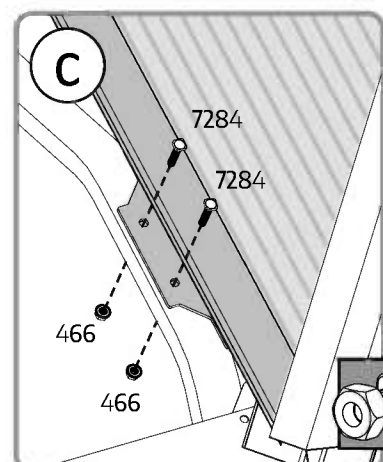
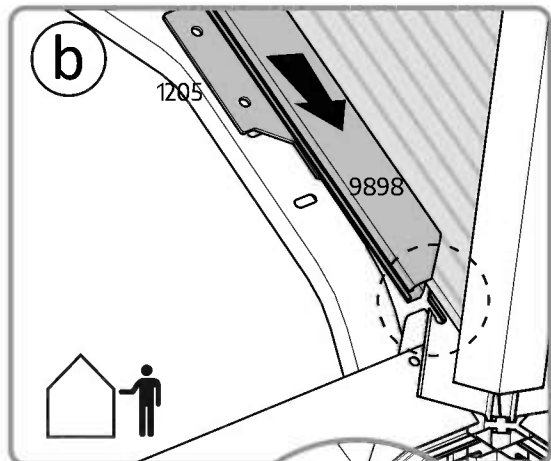
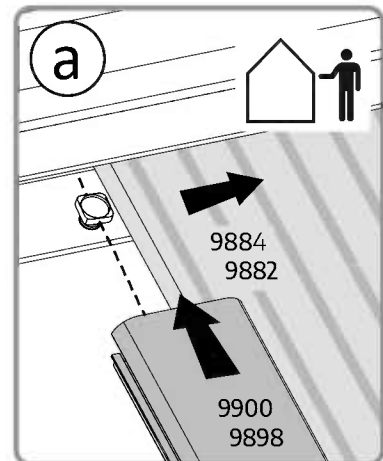
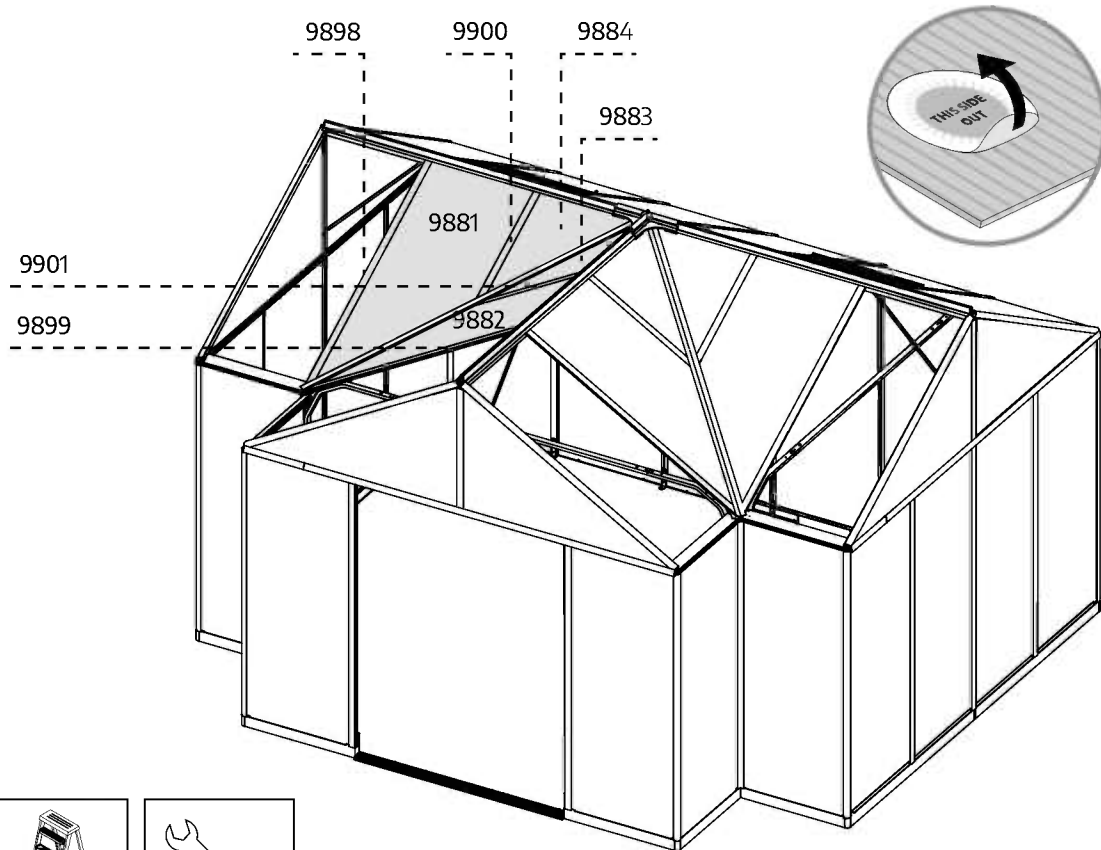

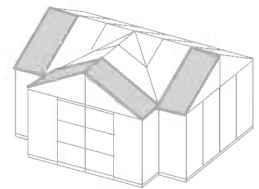

9879  4

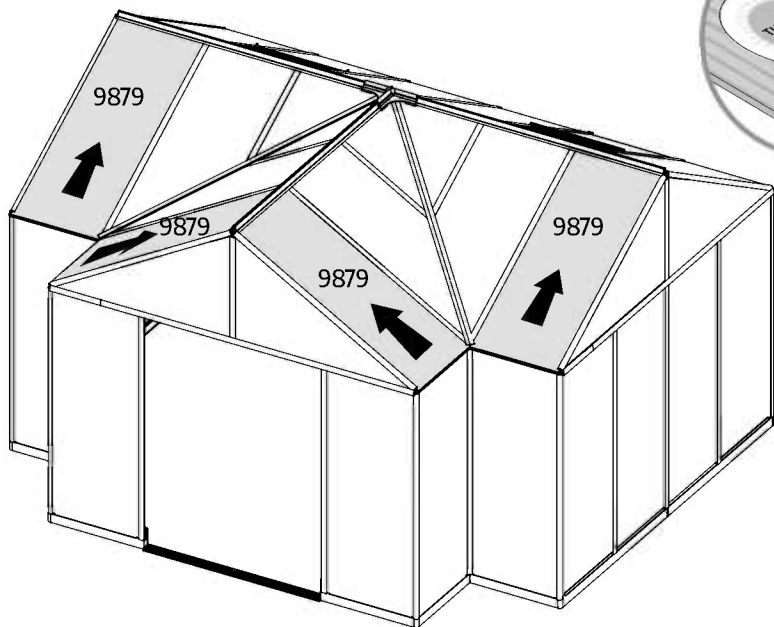
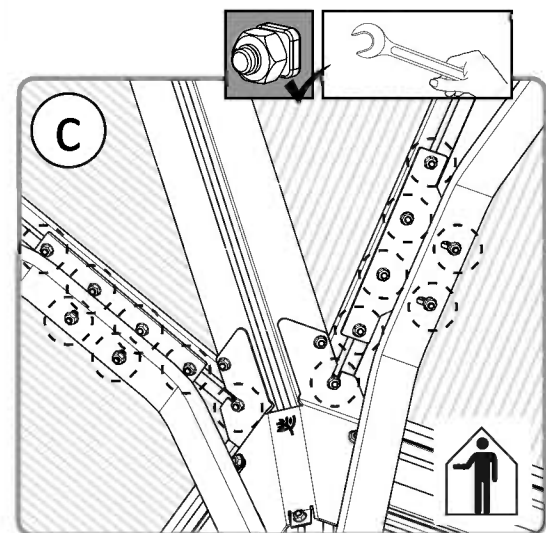
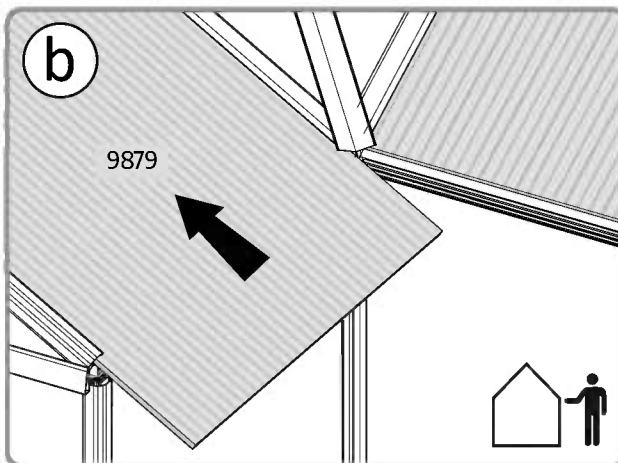
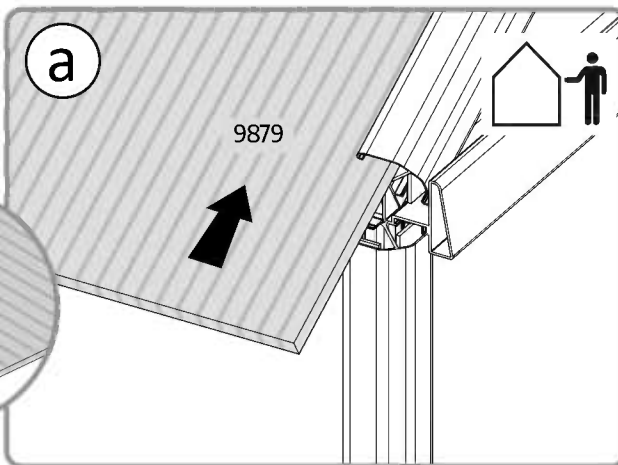
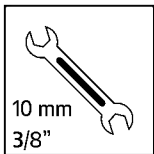

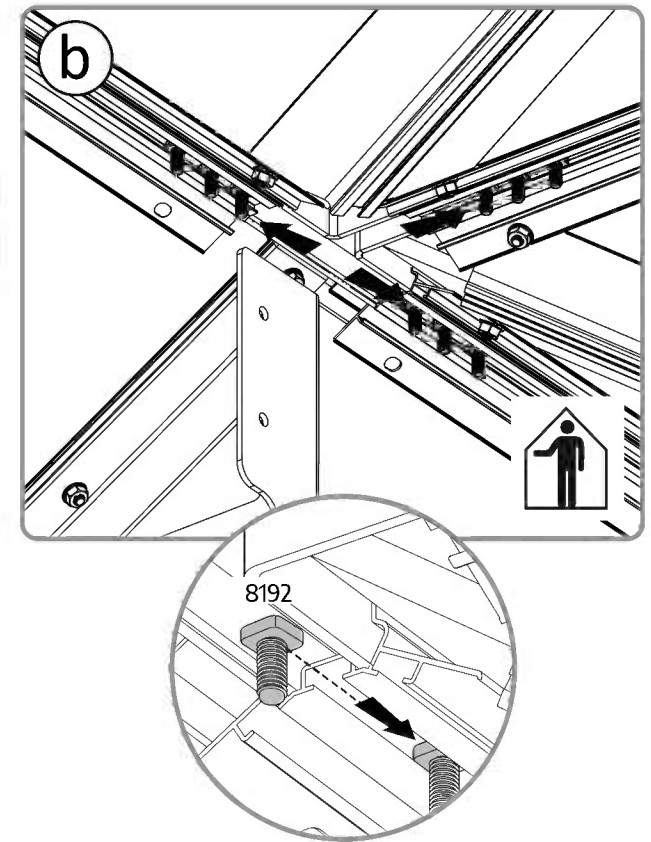
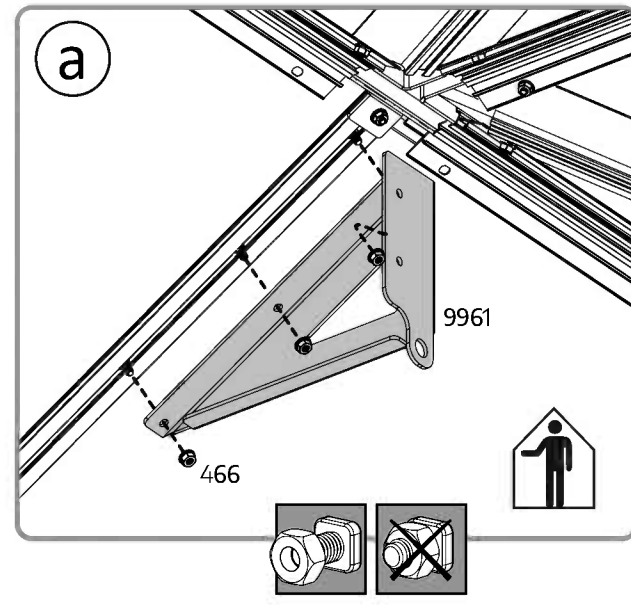
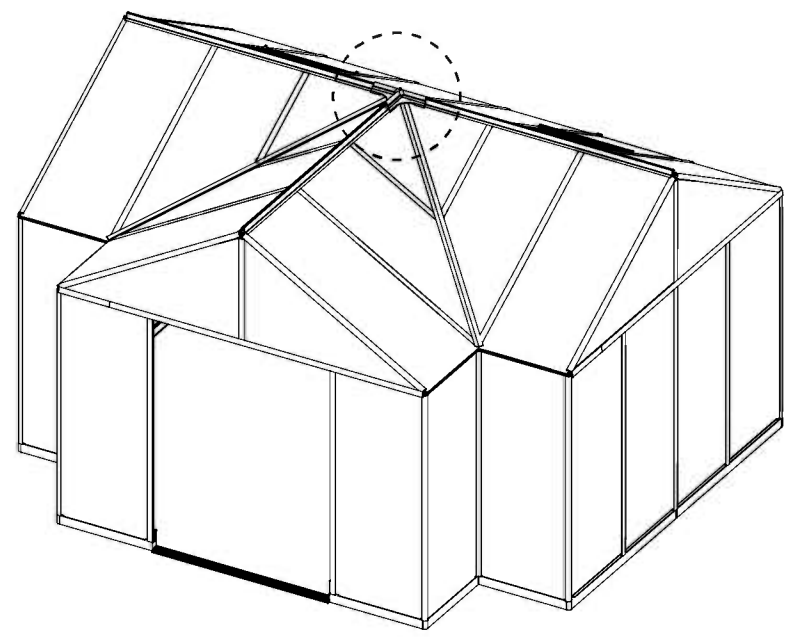
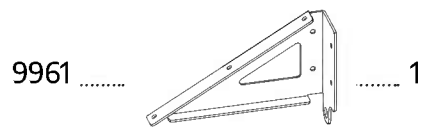
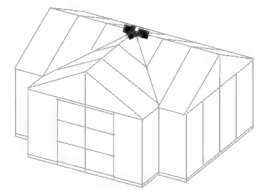

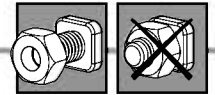
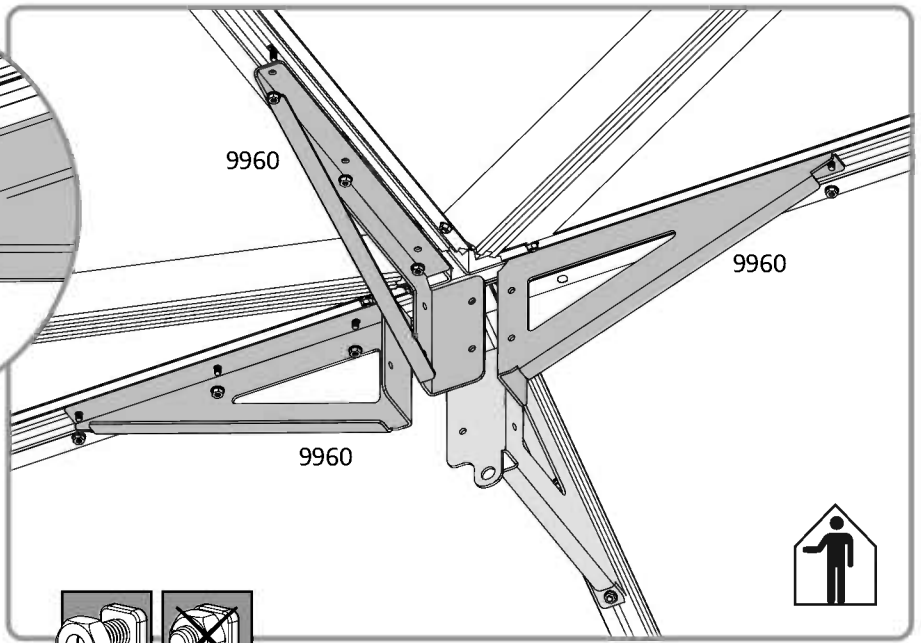
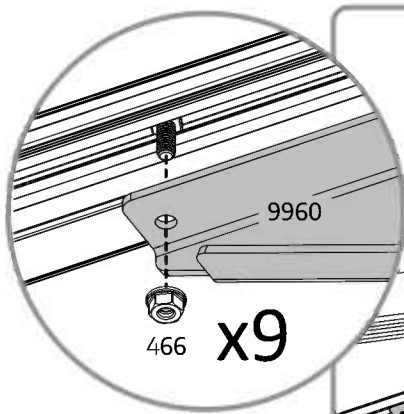
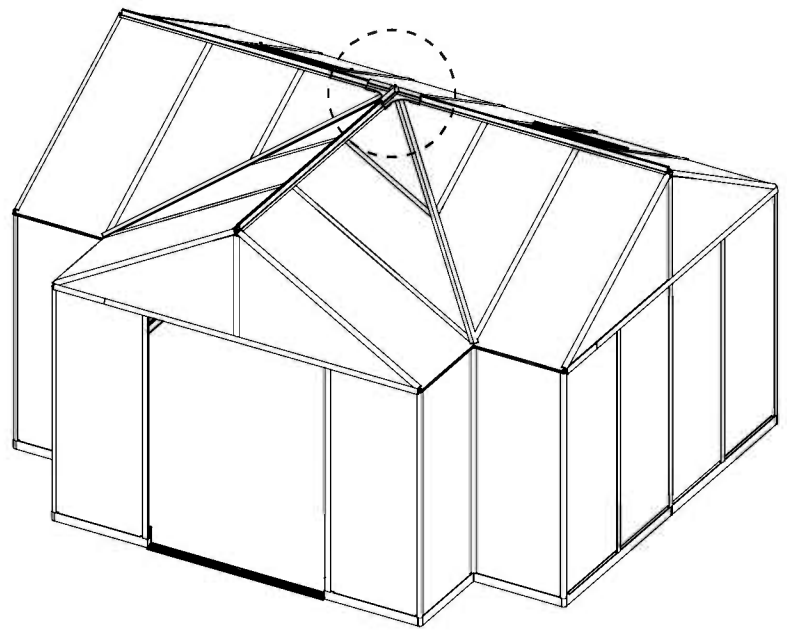
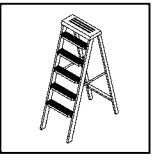
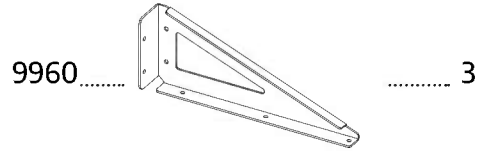
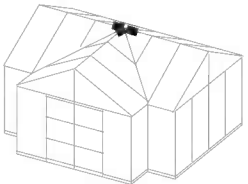



Before tightening the screws (Drawing a) make sure that all the profiles 9906 are leveled.

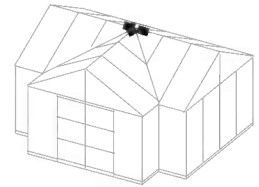

7221  8

466  8

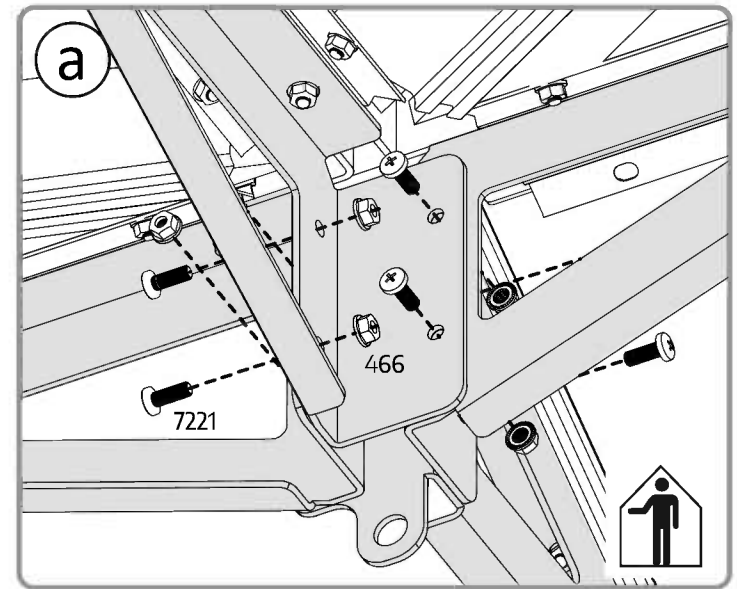
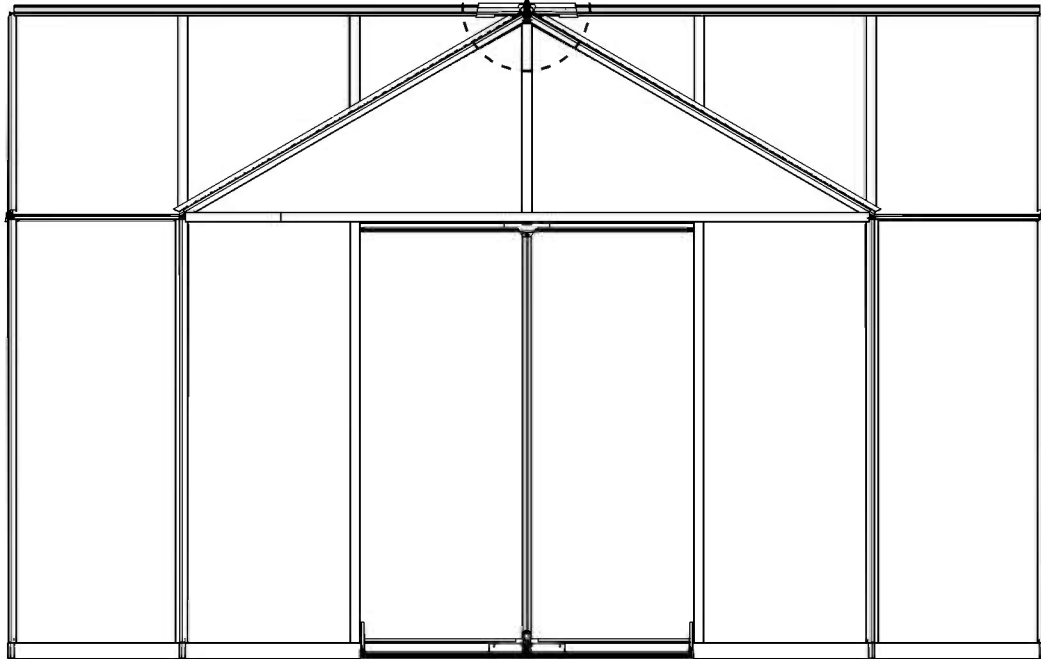
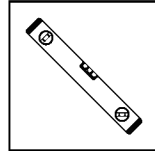
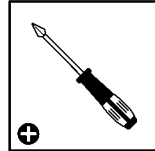
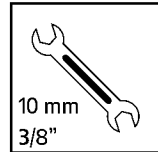

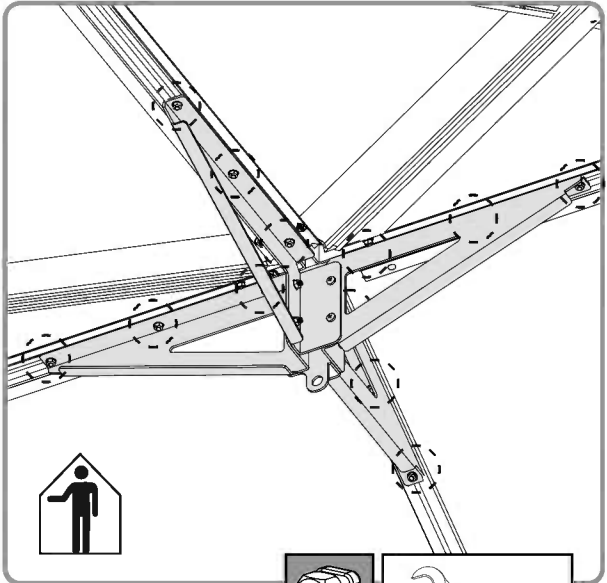
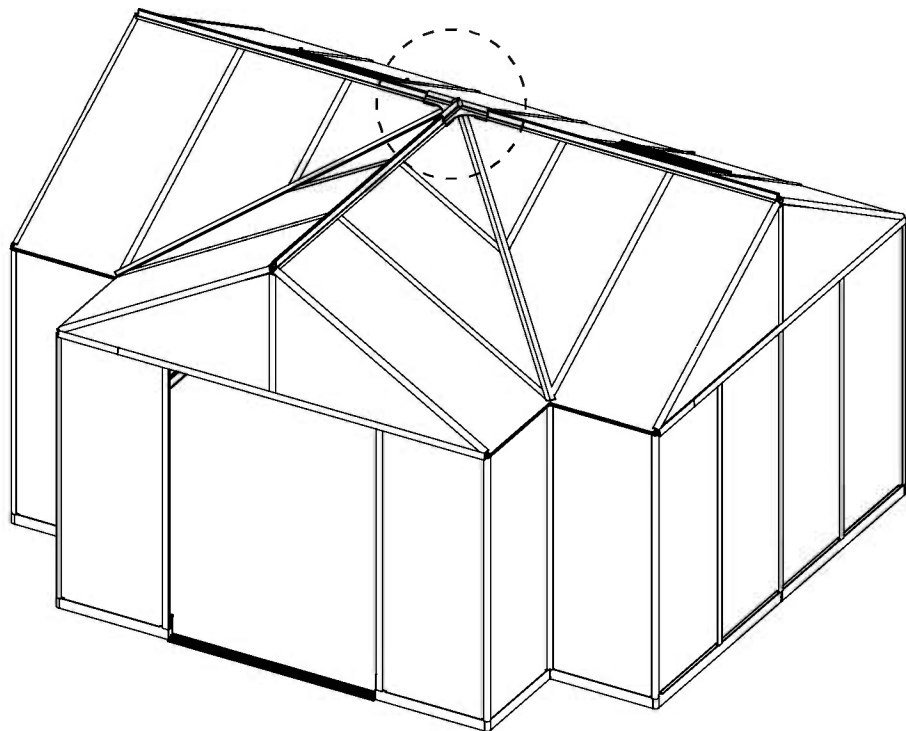
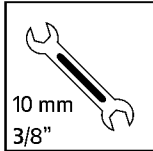
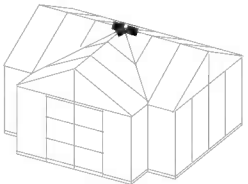

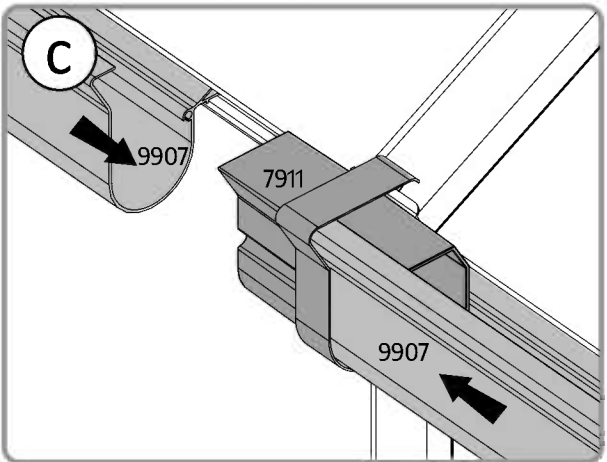
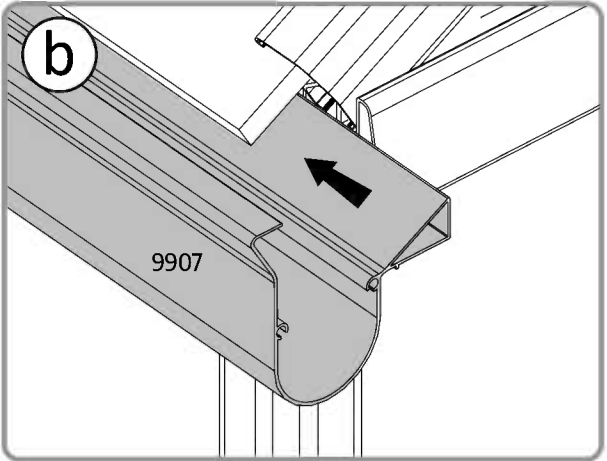
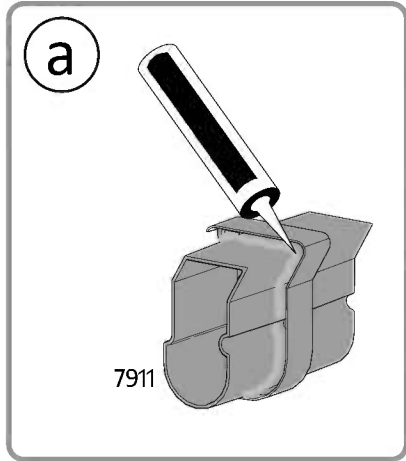
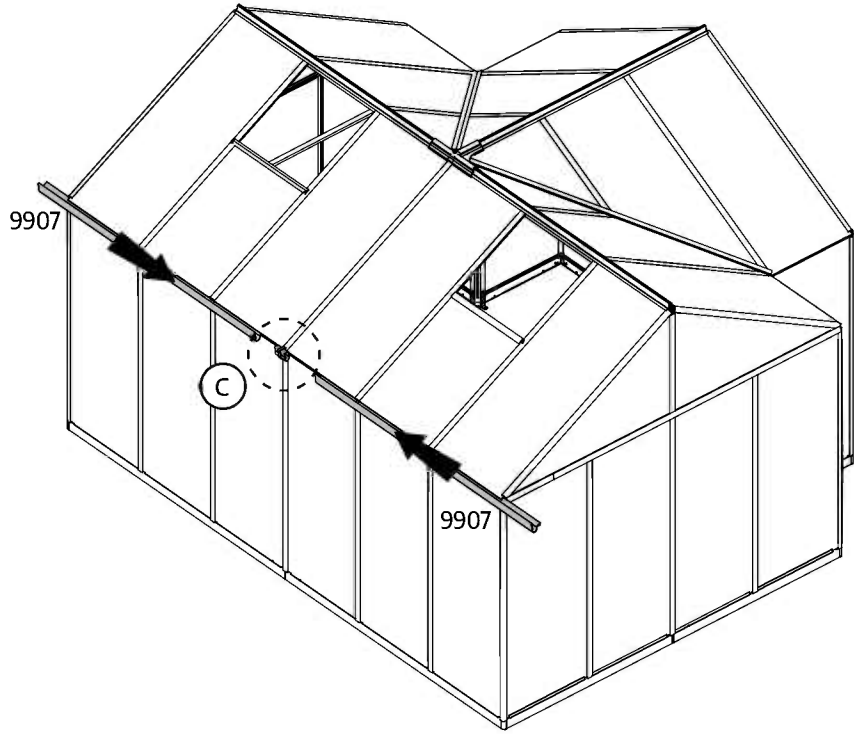
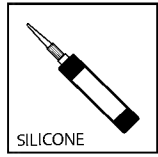
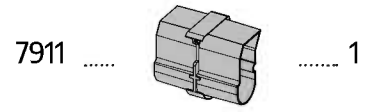
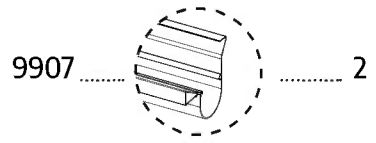
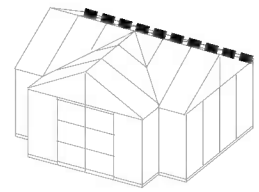

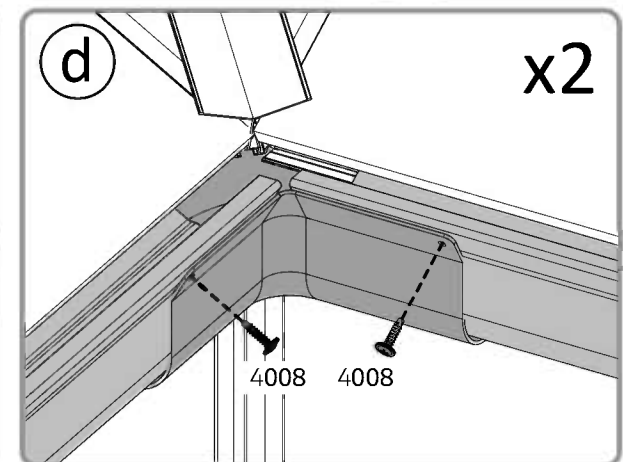
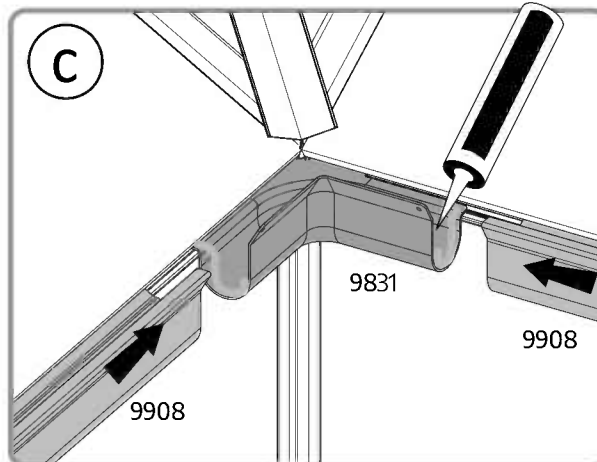
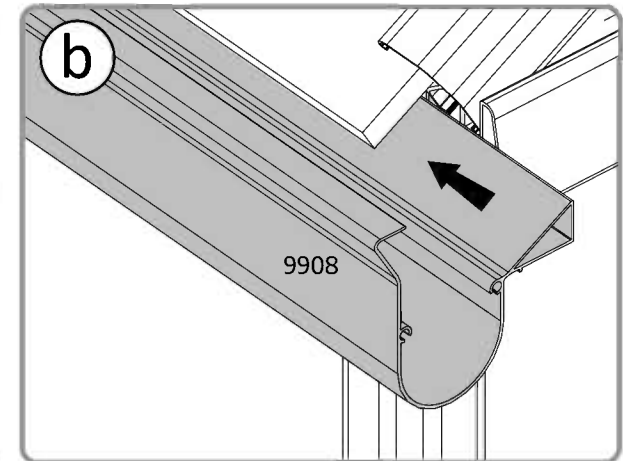
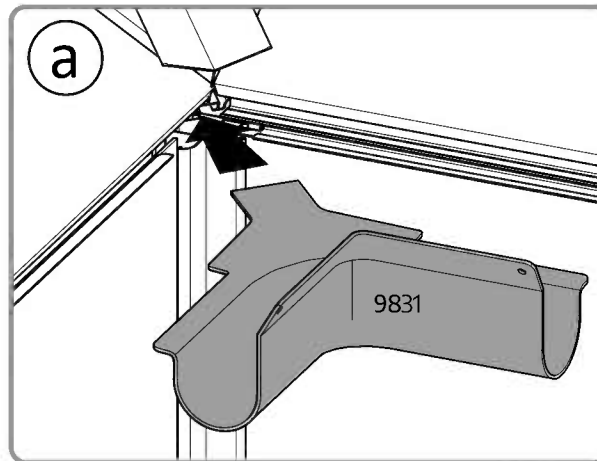
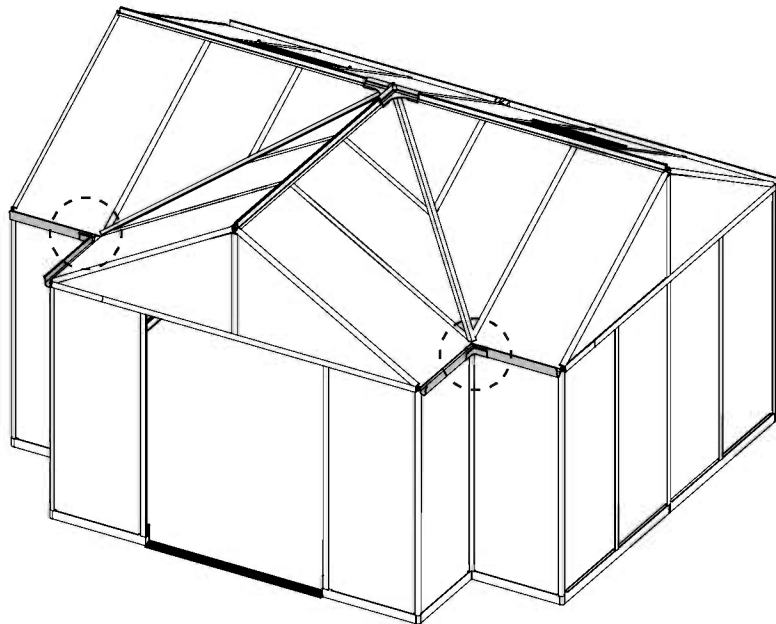
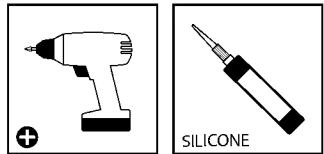
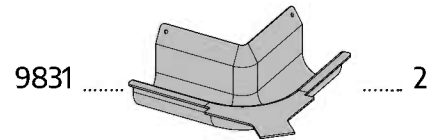
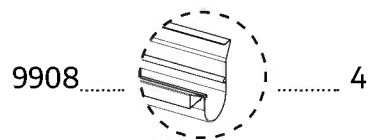
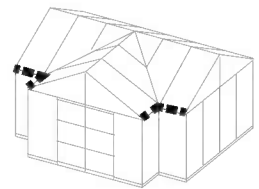

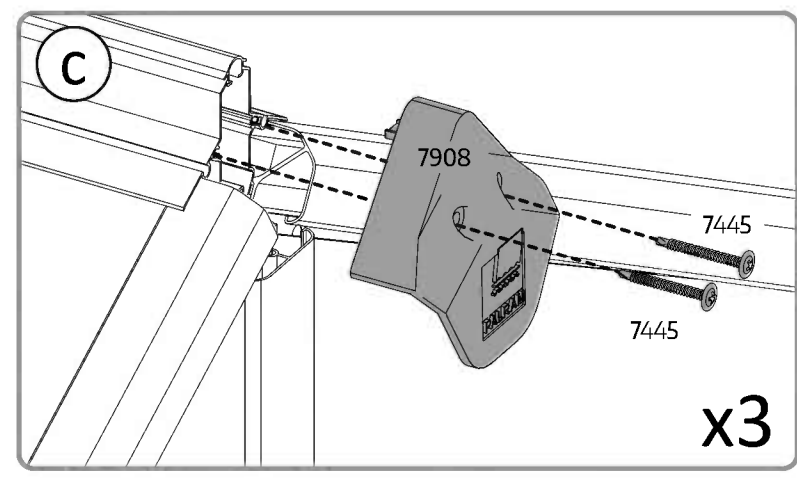
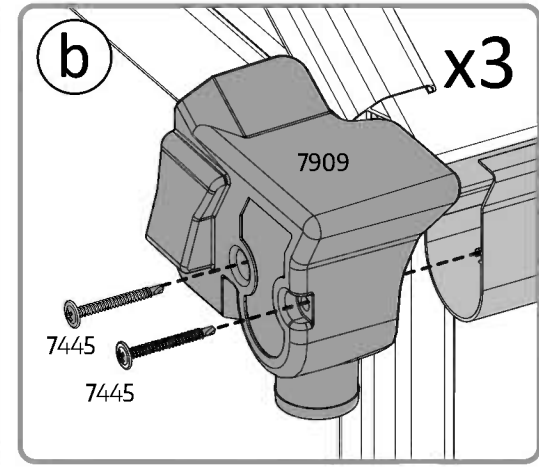
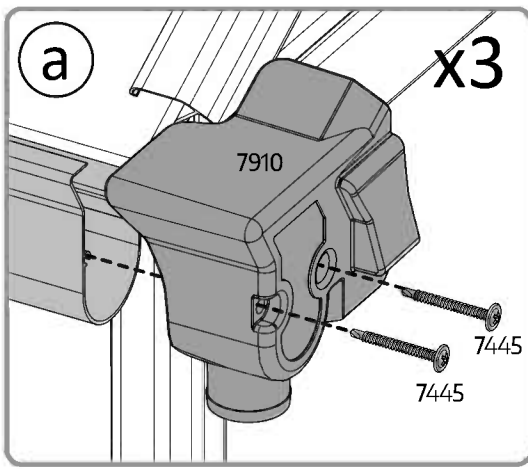
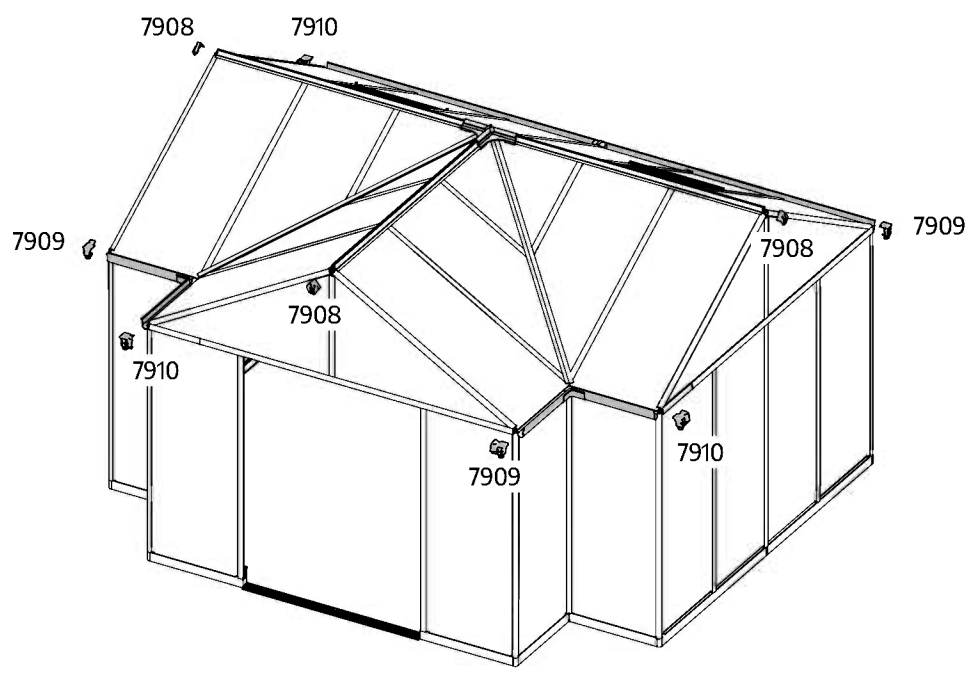
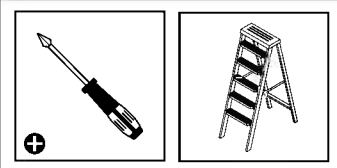
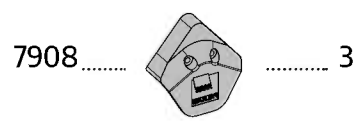
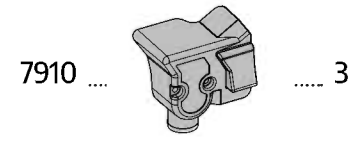
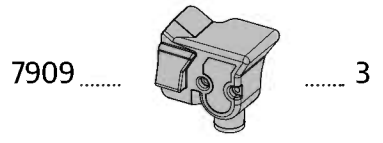
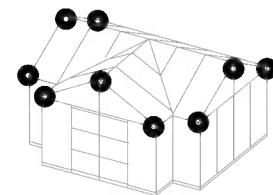

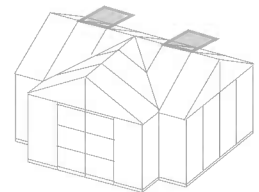

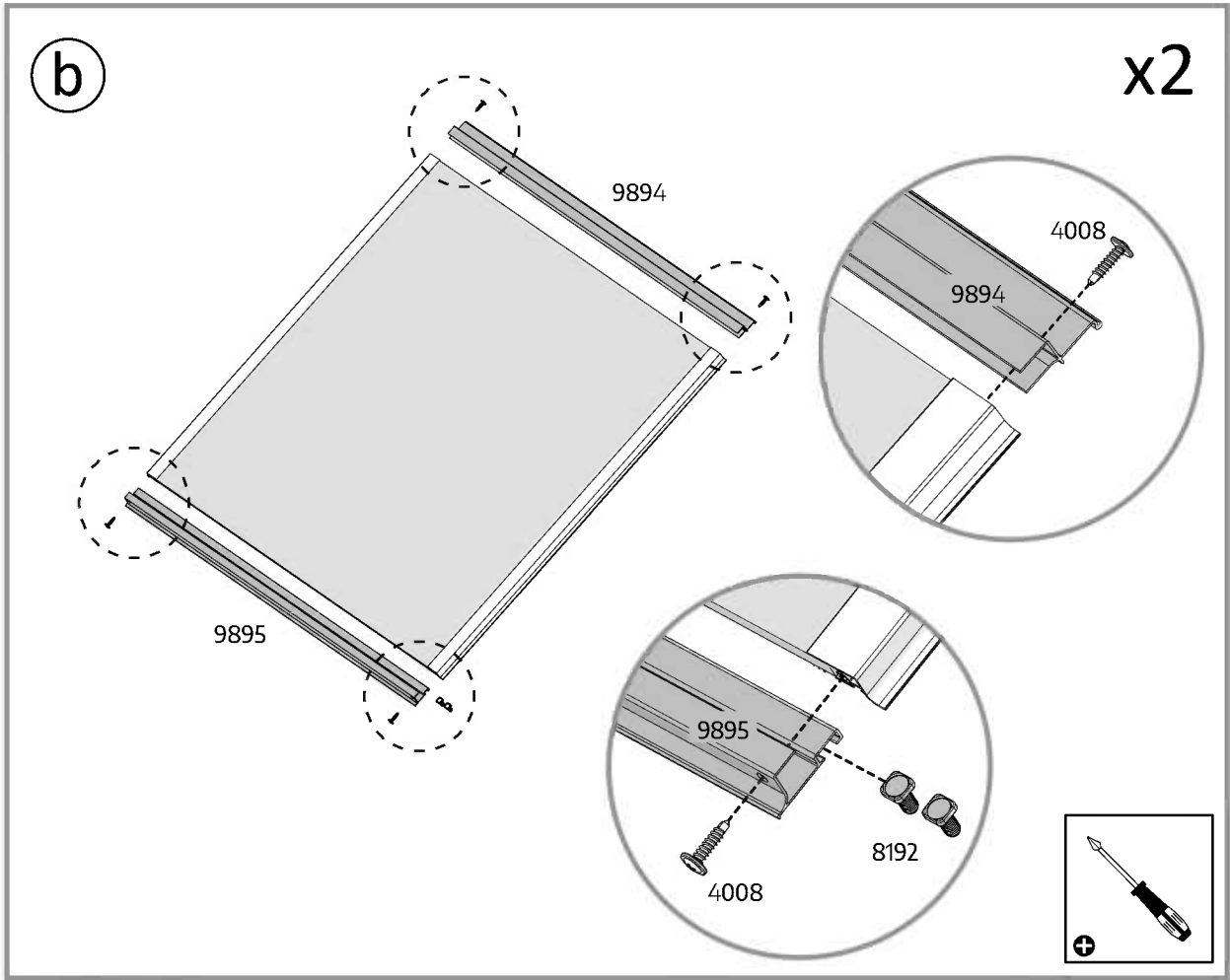
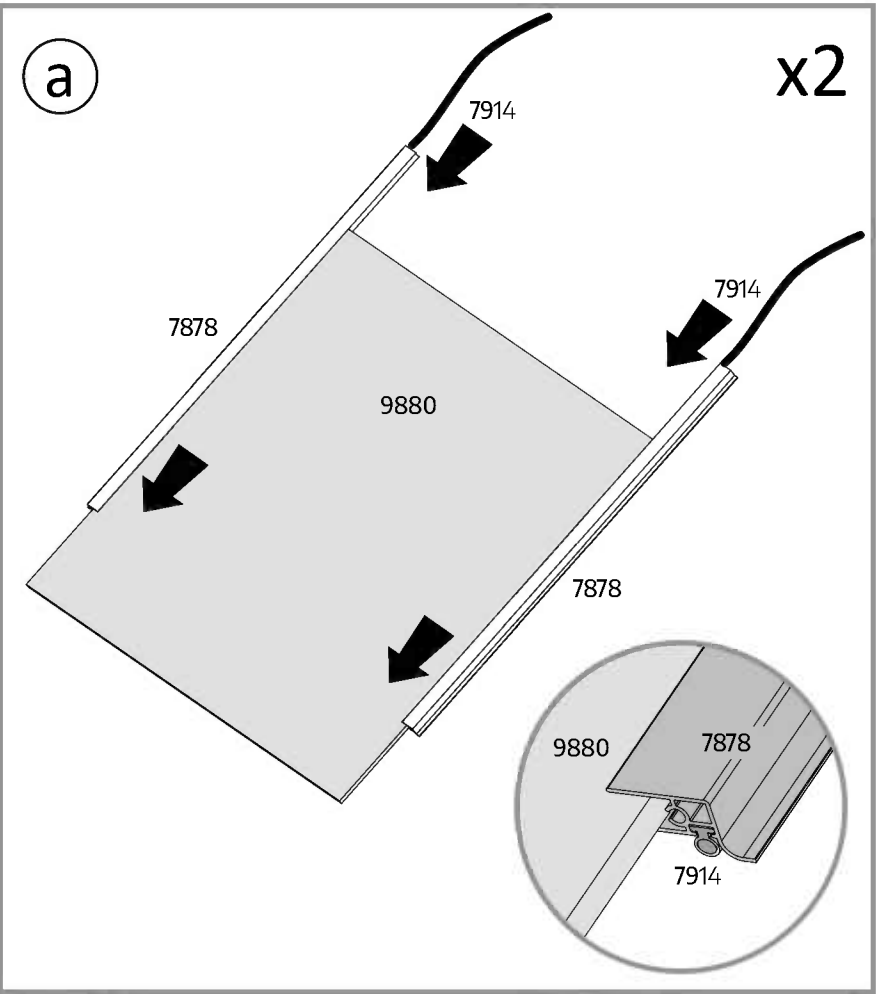

- 9880 2
- 7878 4
- 7914 4
- 9894 2
- 9895 2
- 4008 8
- 8192 4

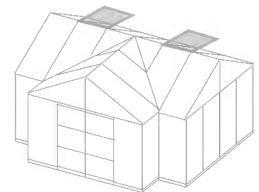



7009  4

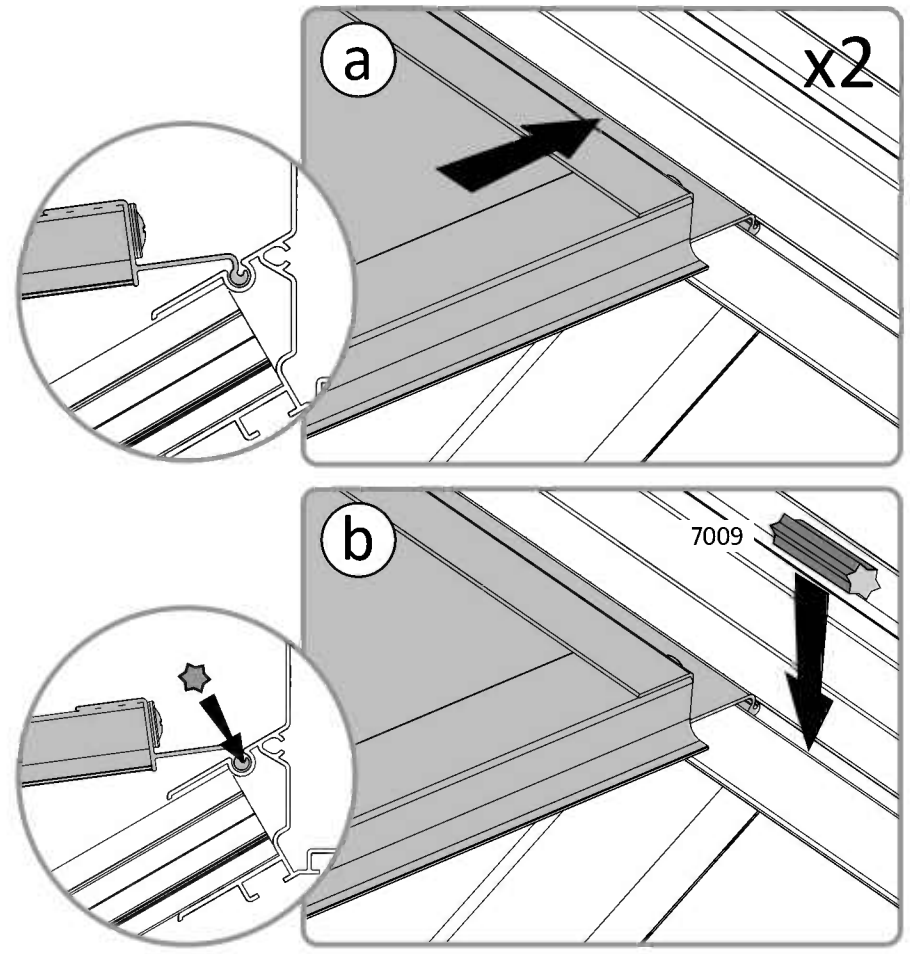
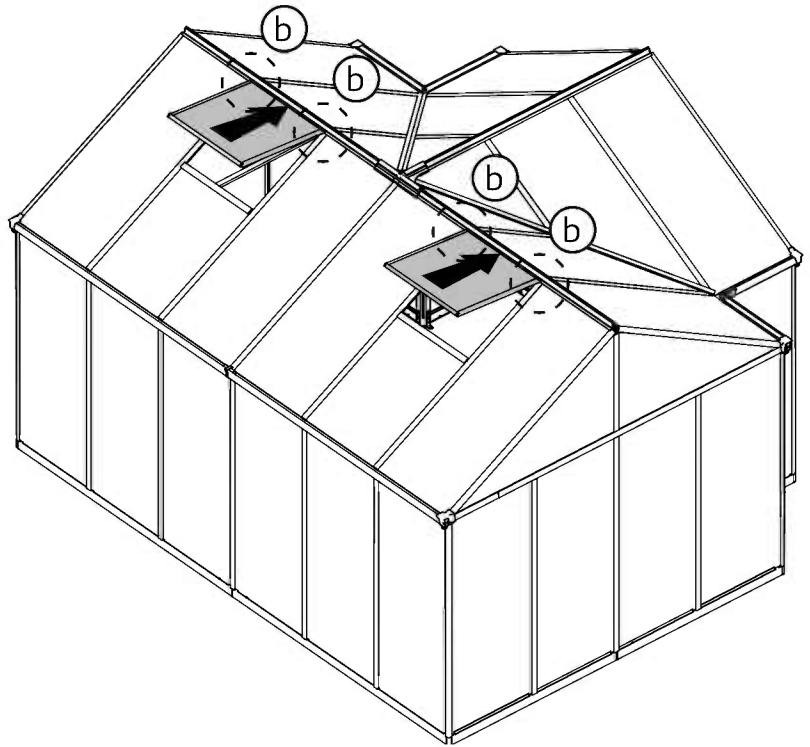
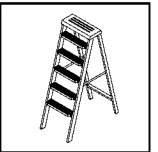



Prior to fitting the Automatic Vent Opener, the power tube has to be cooled by placing it in a refrigerator for approximately 30 minutes.

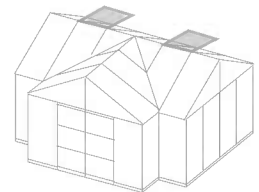

8107 2 964 2 1204 2 421 8 422 8

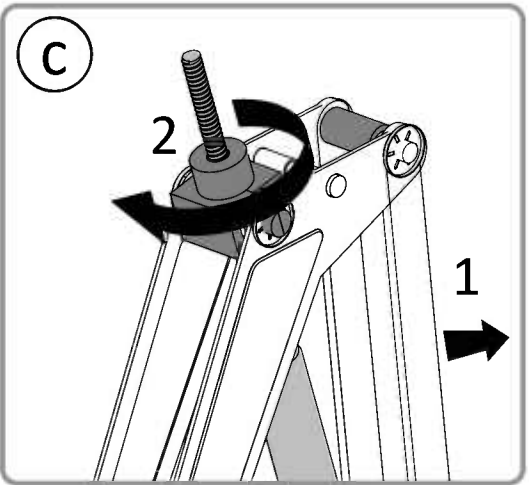
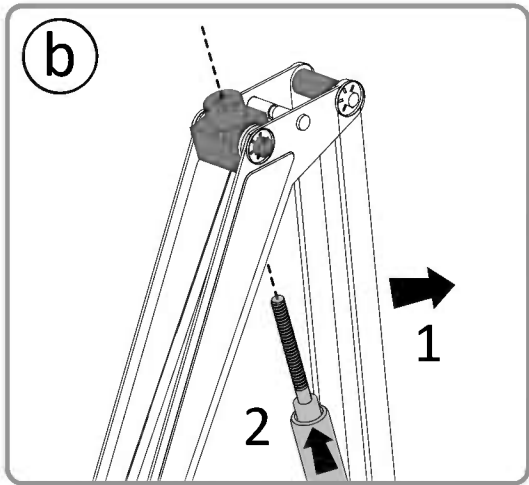
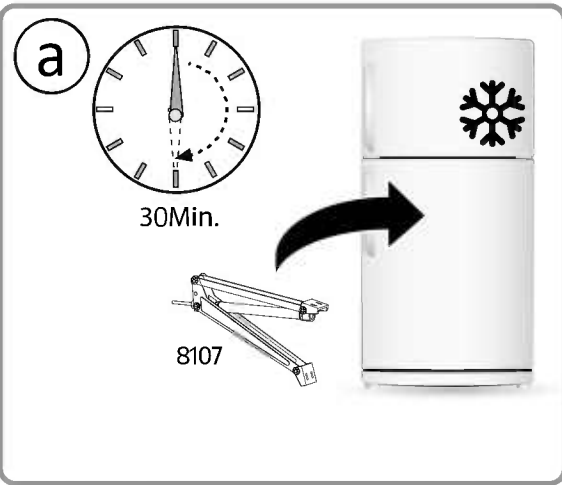

x2

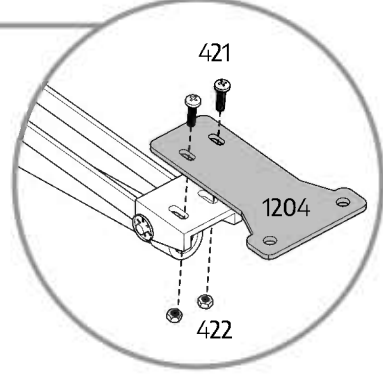
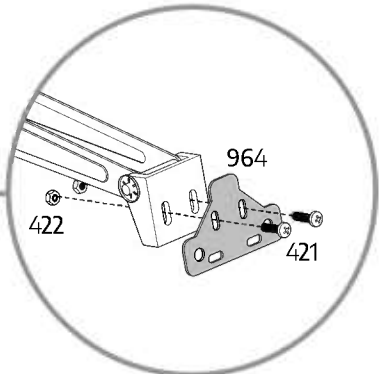
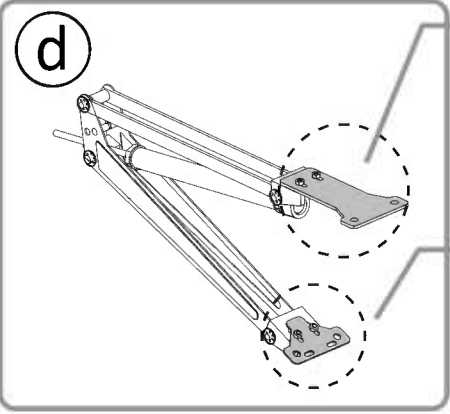

~~465~~
*DO NOT USE





In order to close the window after fitting the Automatic Vent opener, the piston must be rotated in the direction as show in **Drawing C**.

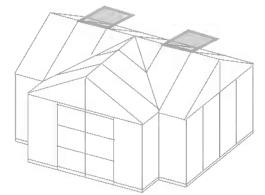

466  8

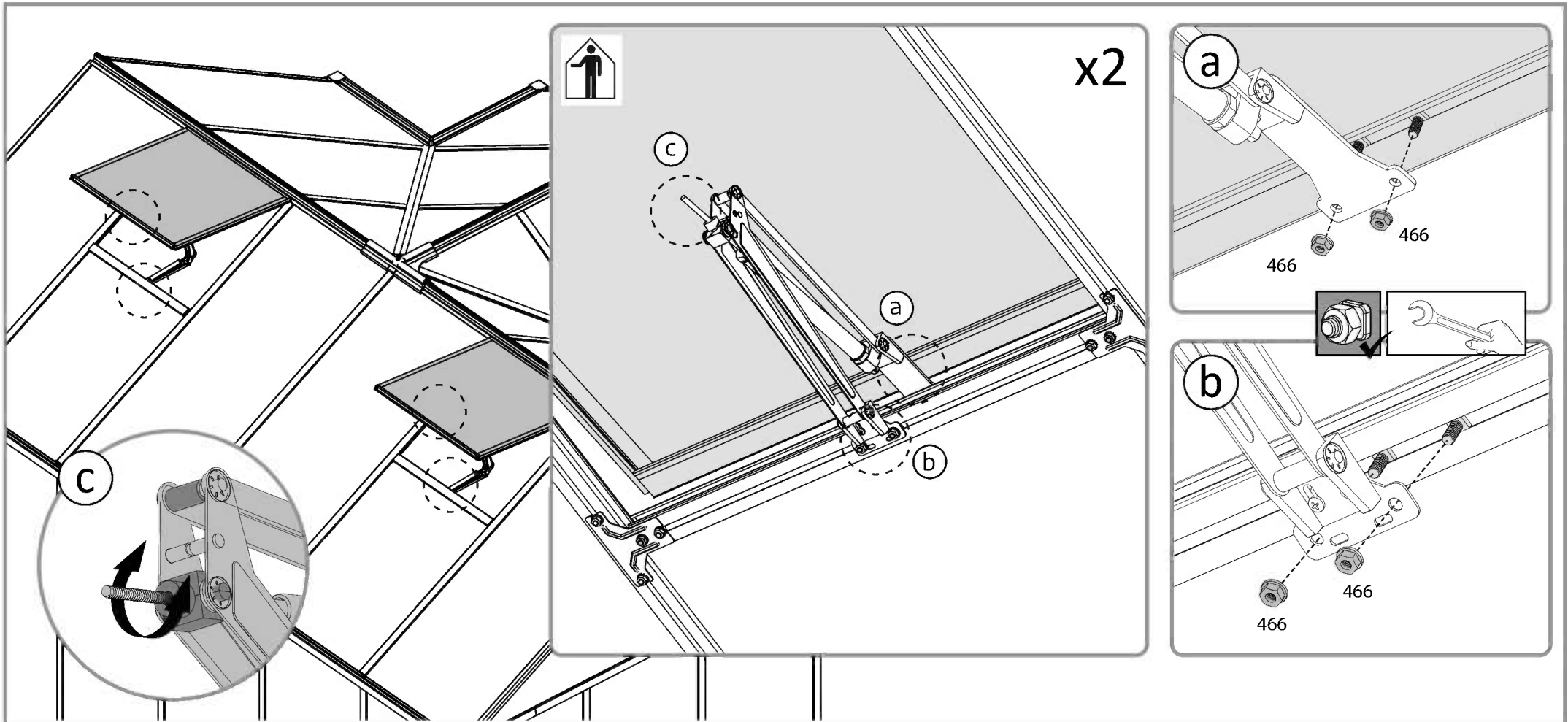



It is recommended to use a carton or other soft material under the lowered corner in order to avoid scratches and peeling of paint.

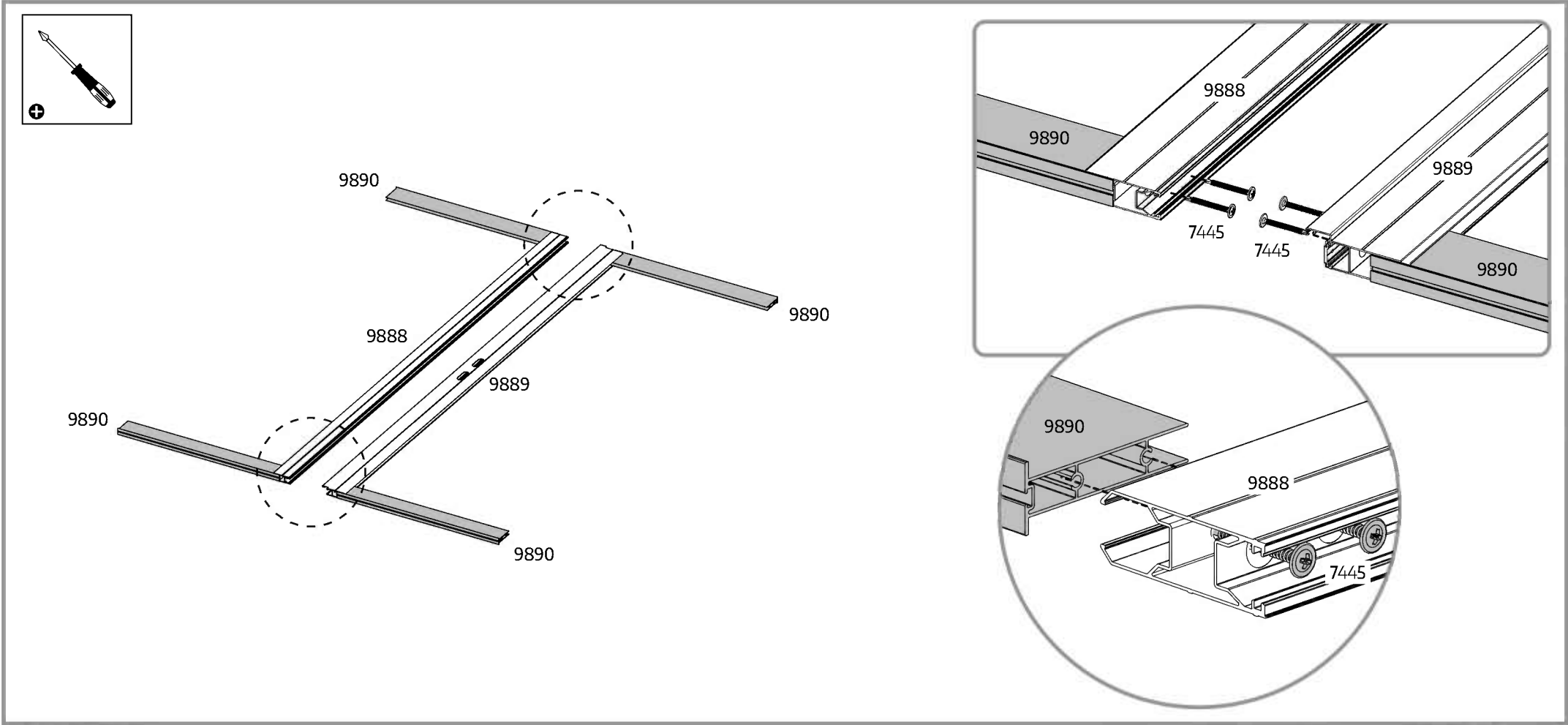
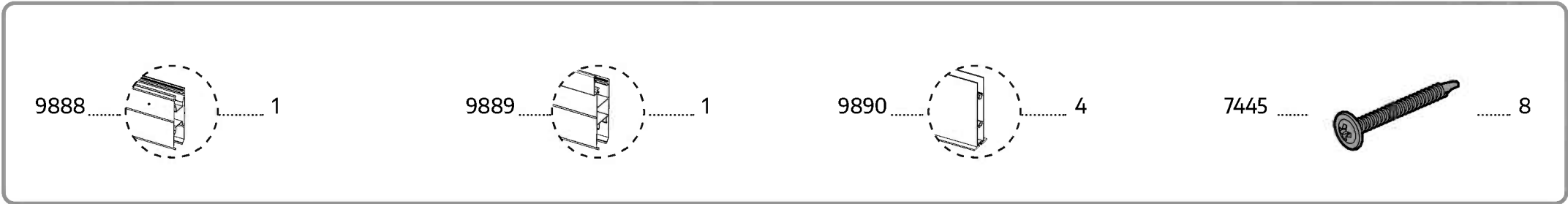
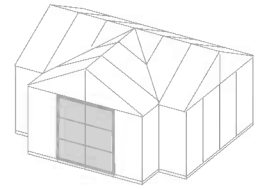

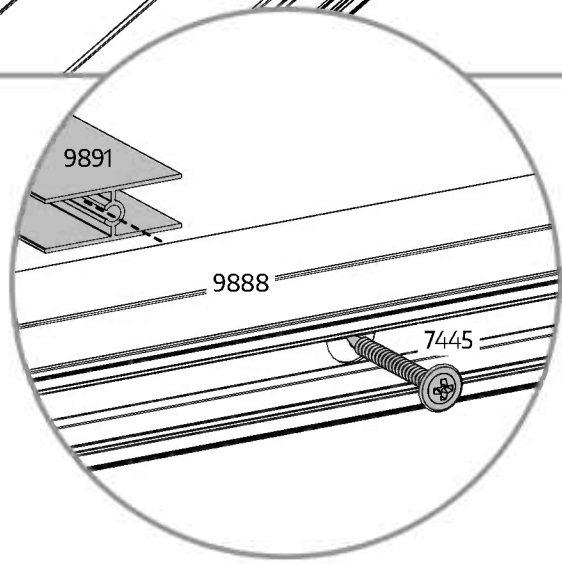
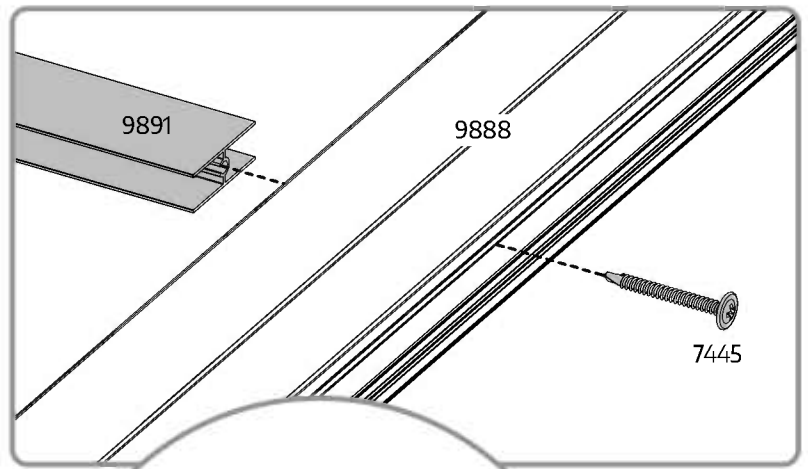
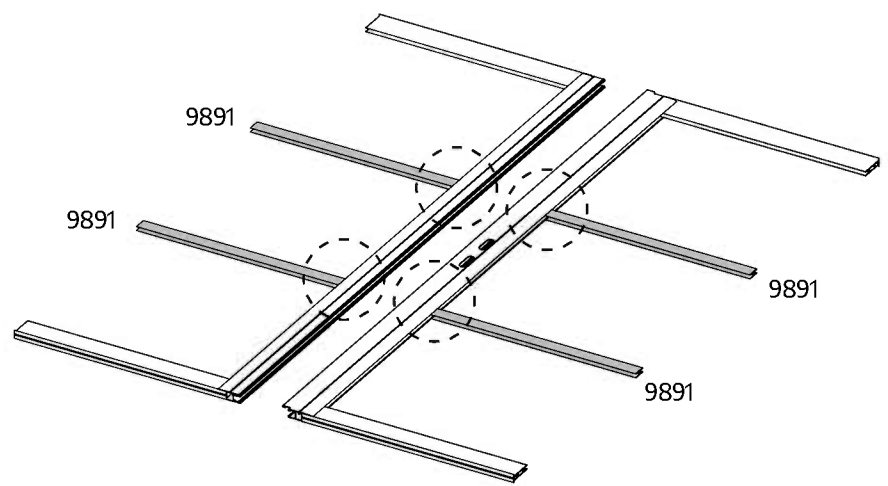
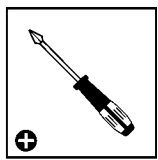
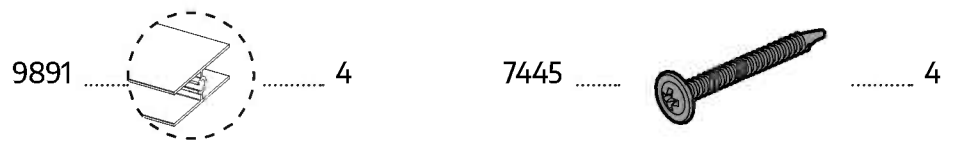
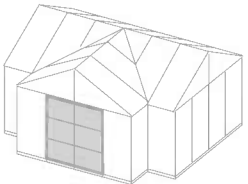

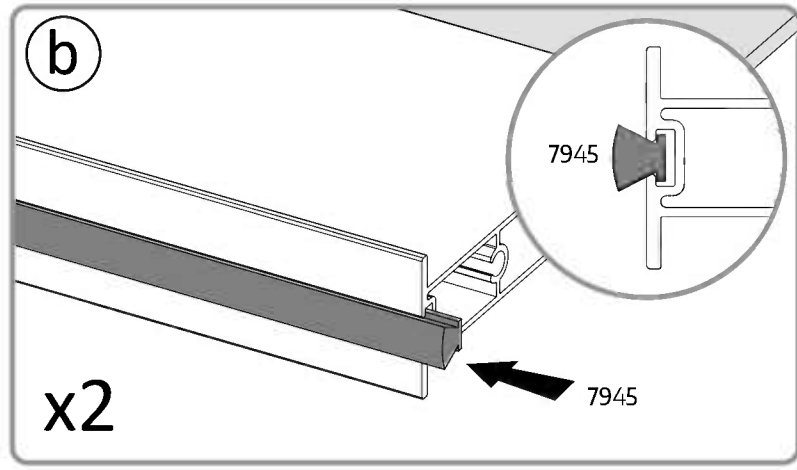
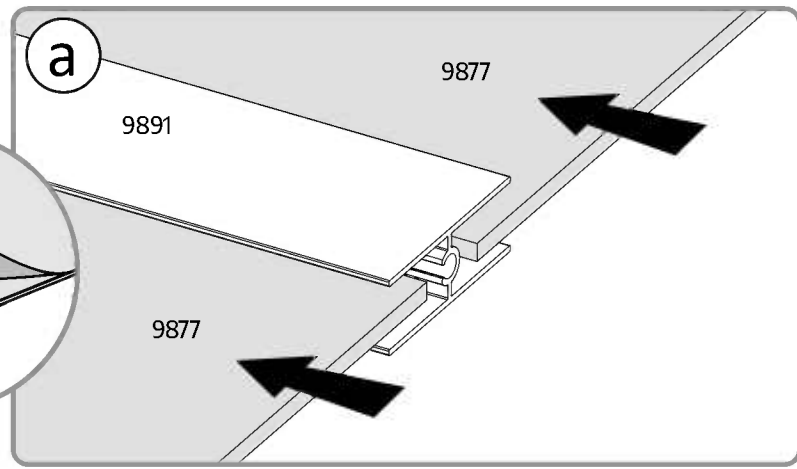
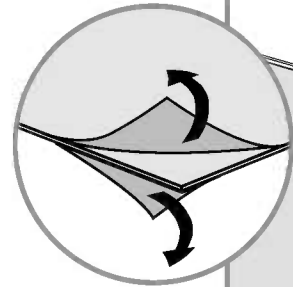
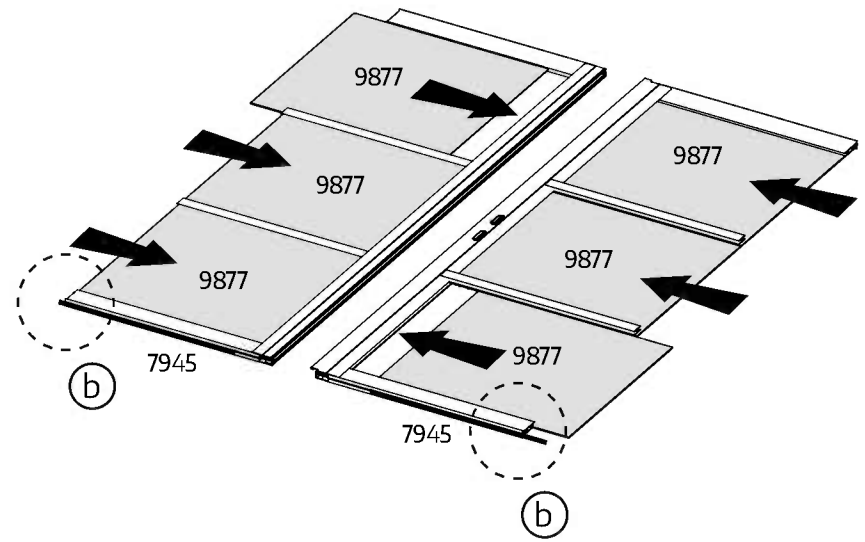
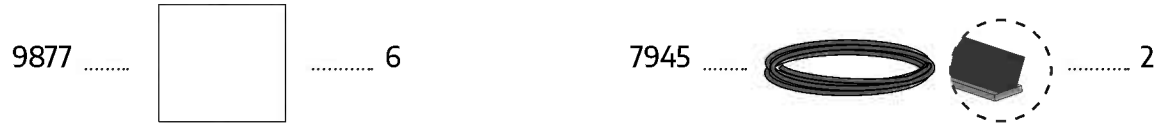
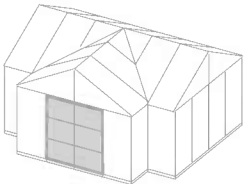

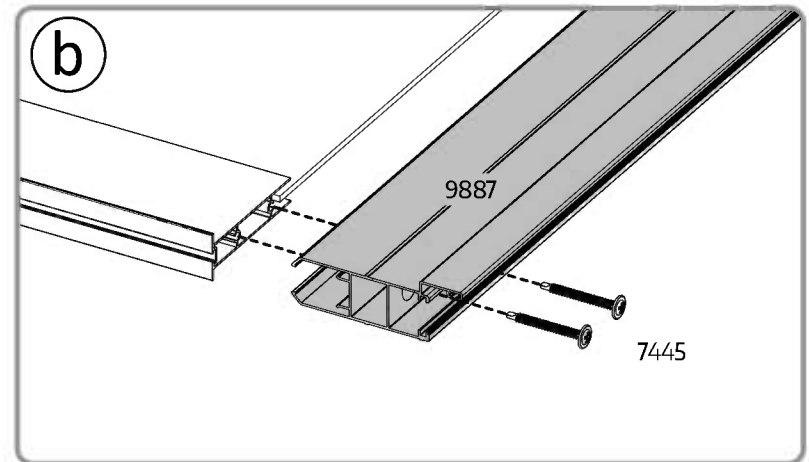
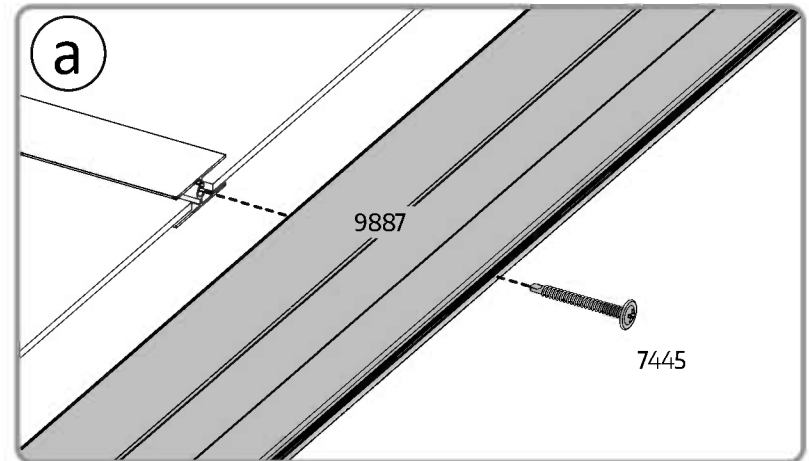
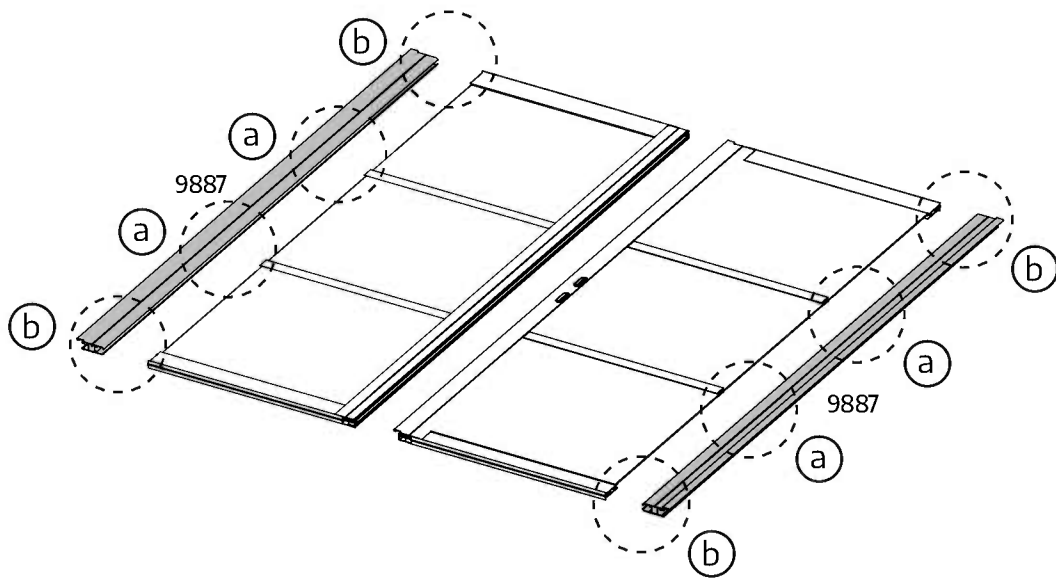
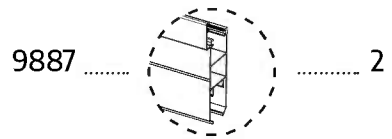
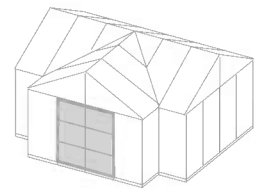

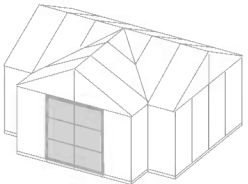

- 9892 4
- 9301 1
- 9708 2

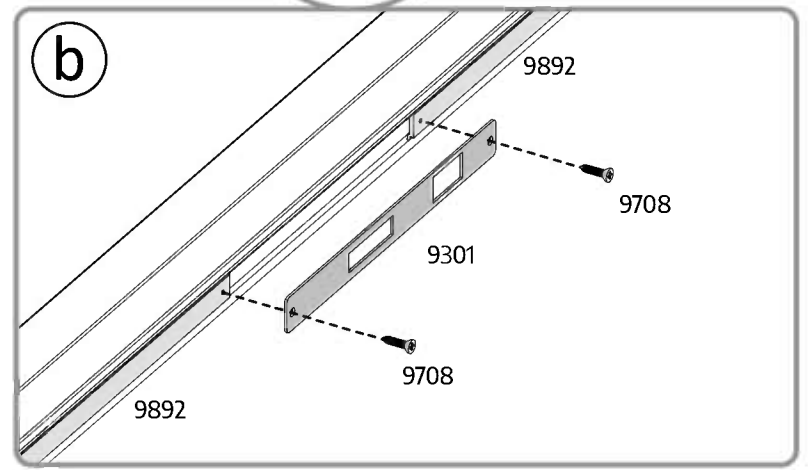
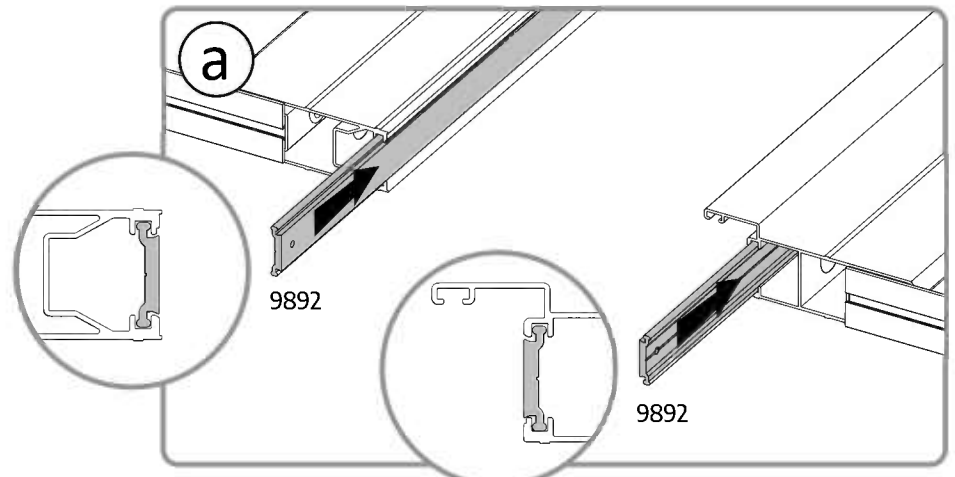
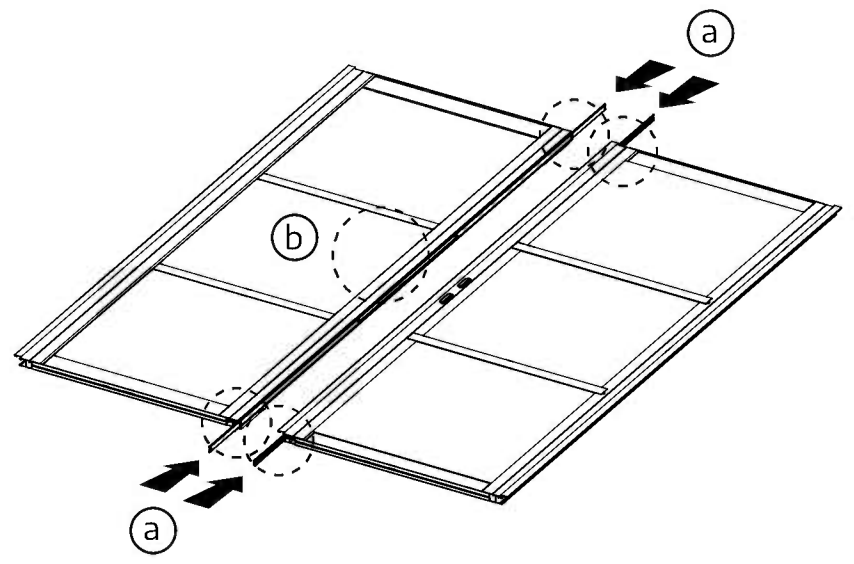



If necessary, you can rotate the cylinder tab. See Figures **a + b**.

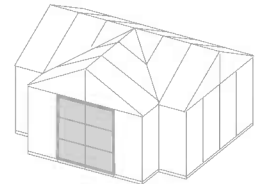

7912 1

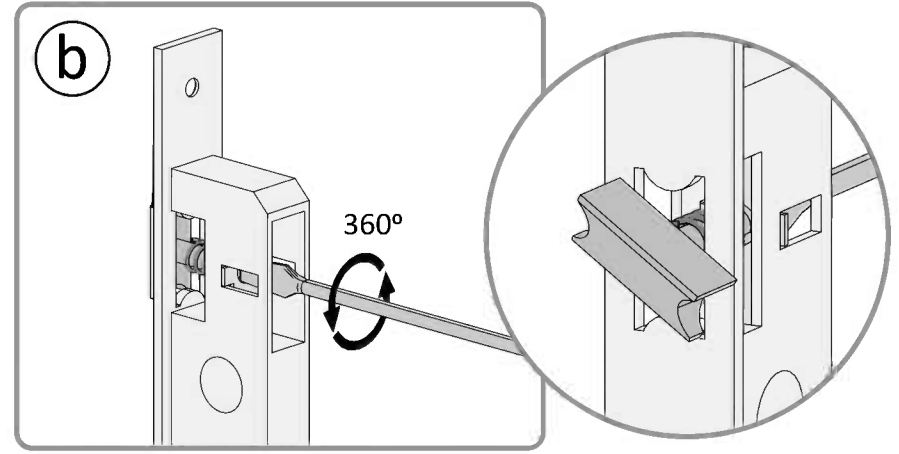
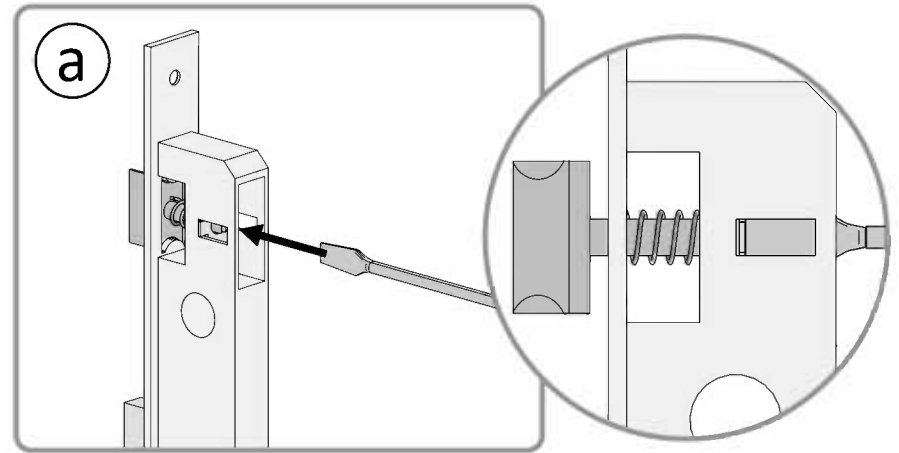
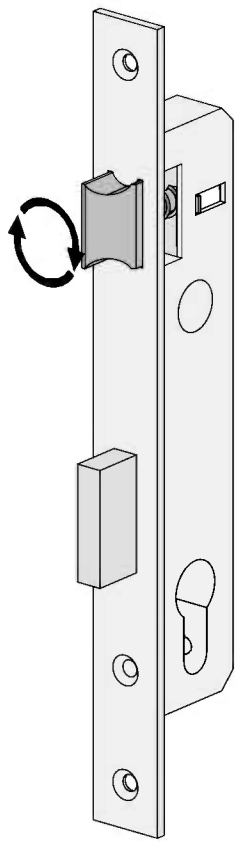
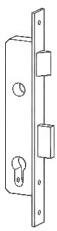

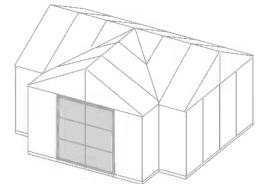

- | | | | | |
|--------------|--------------|--------------|--------------|--------------|
| 7912 1 | 7913 1 | 8039 3 | 7958 1 | 7445 4 |
| | | | | |
| | | | | 9708 2 |
| | | | | |

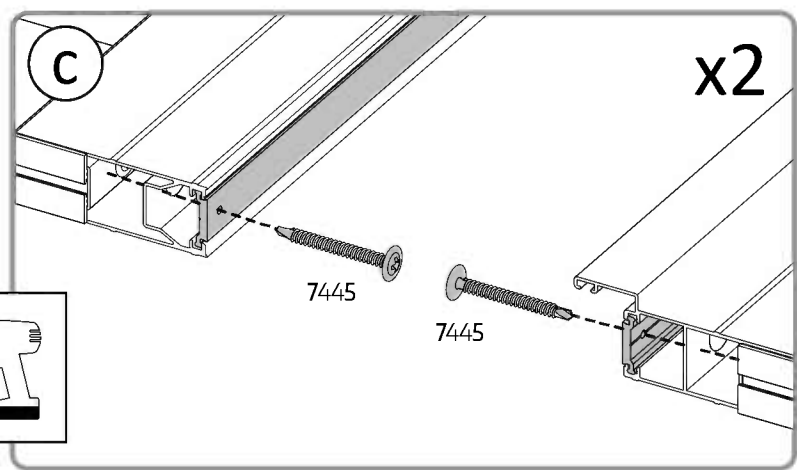
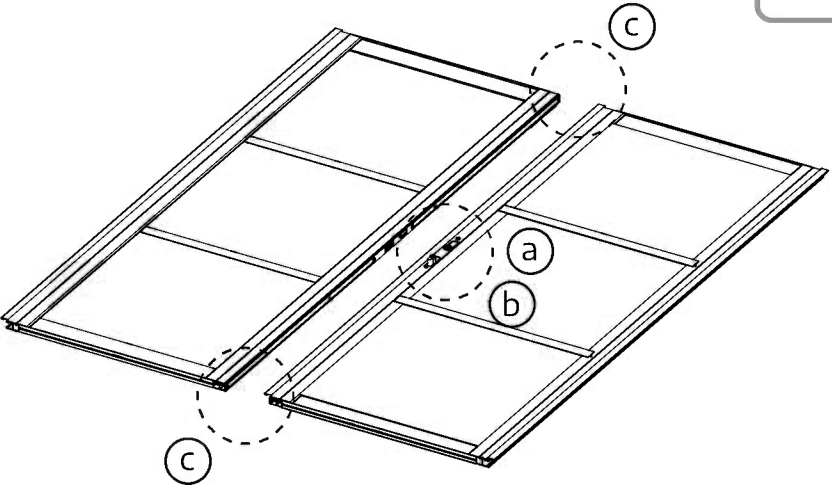
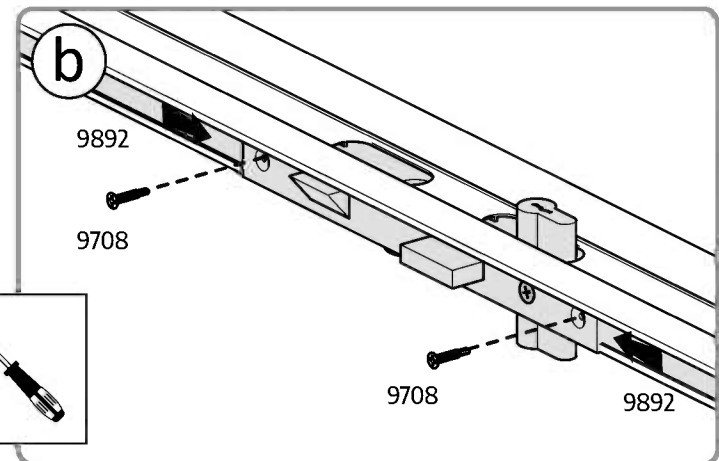
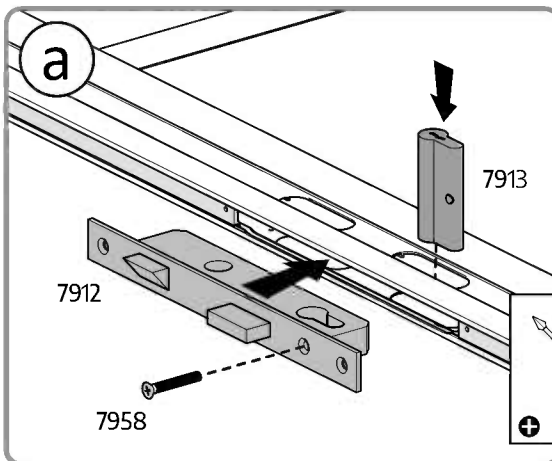

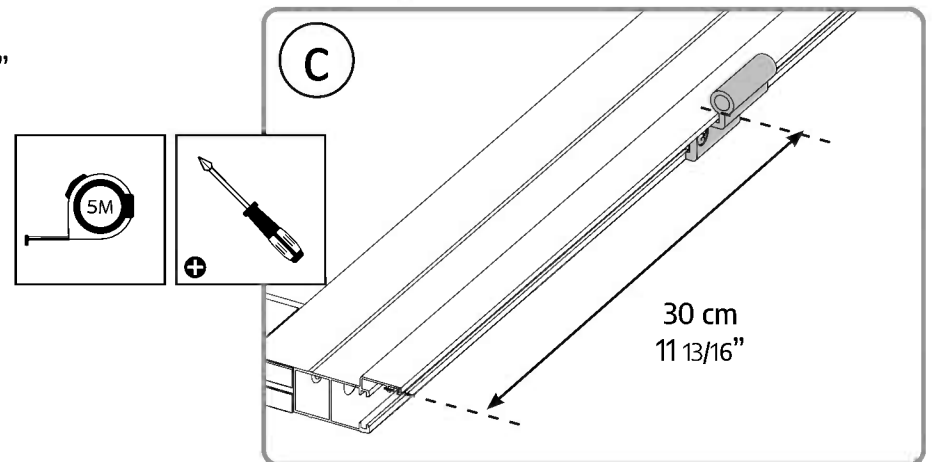
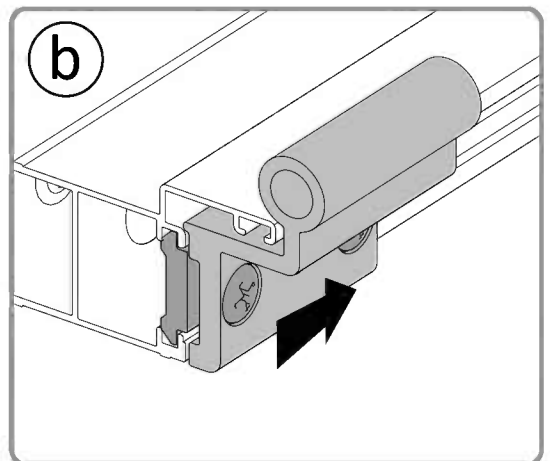
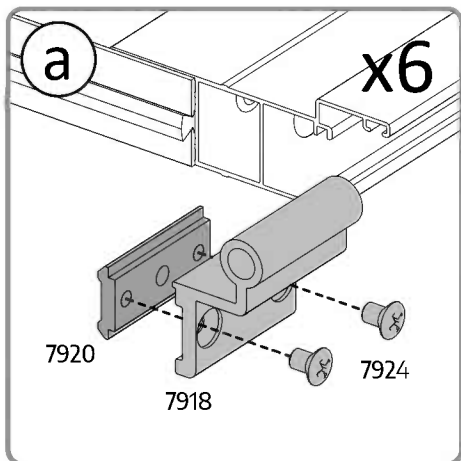
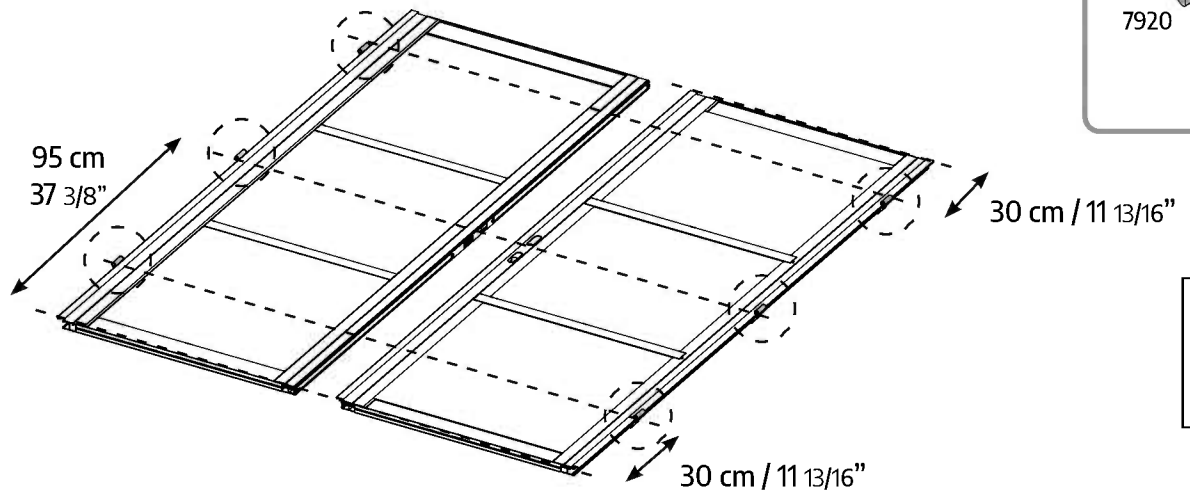
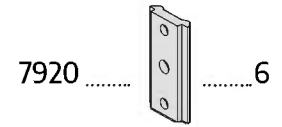
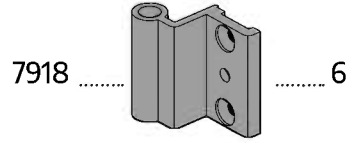
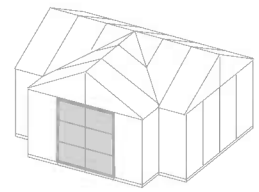

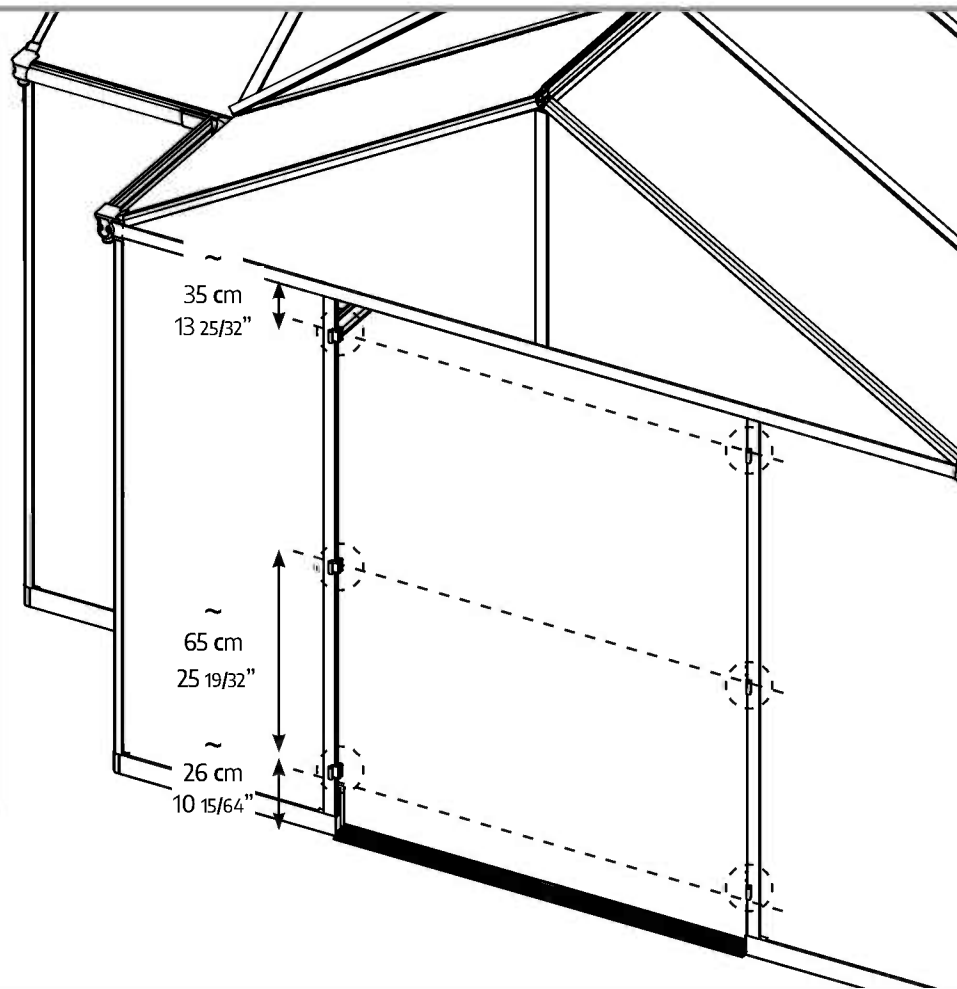
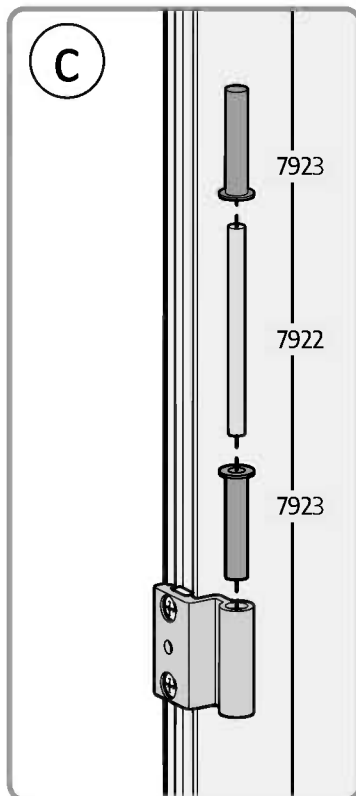
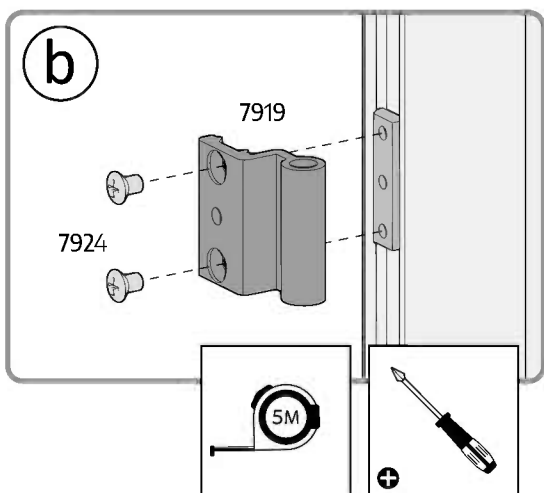
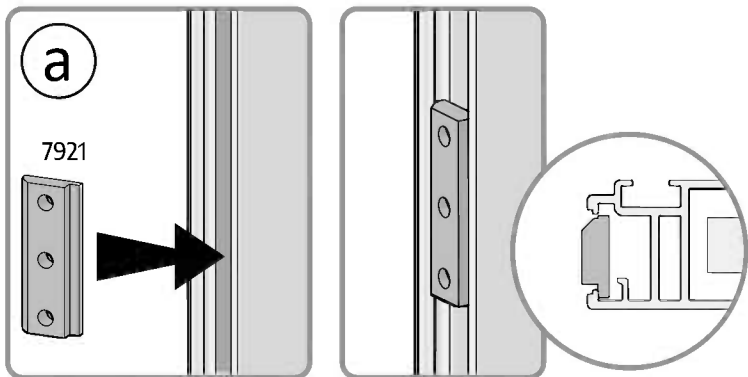
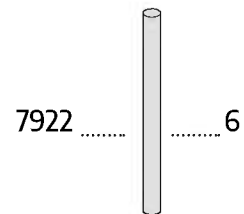
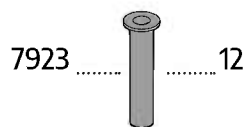
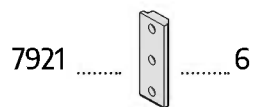
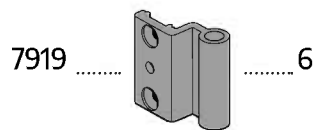
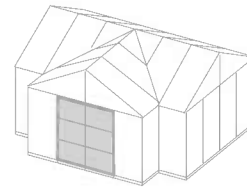

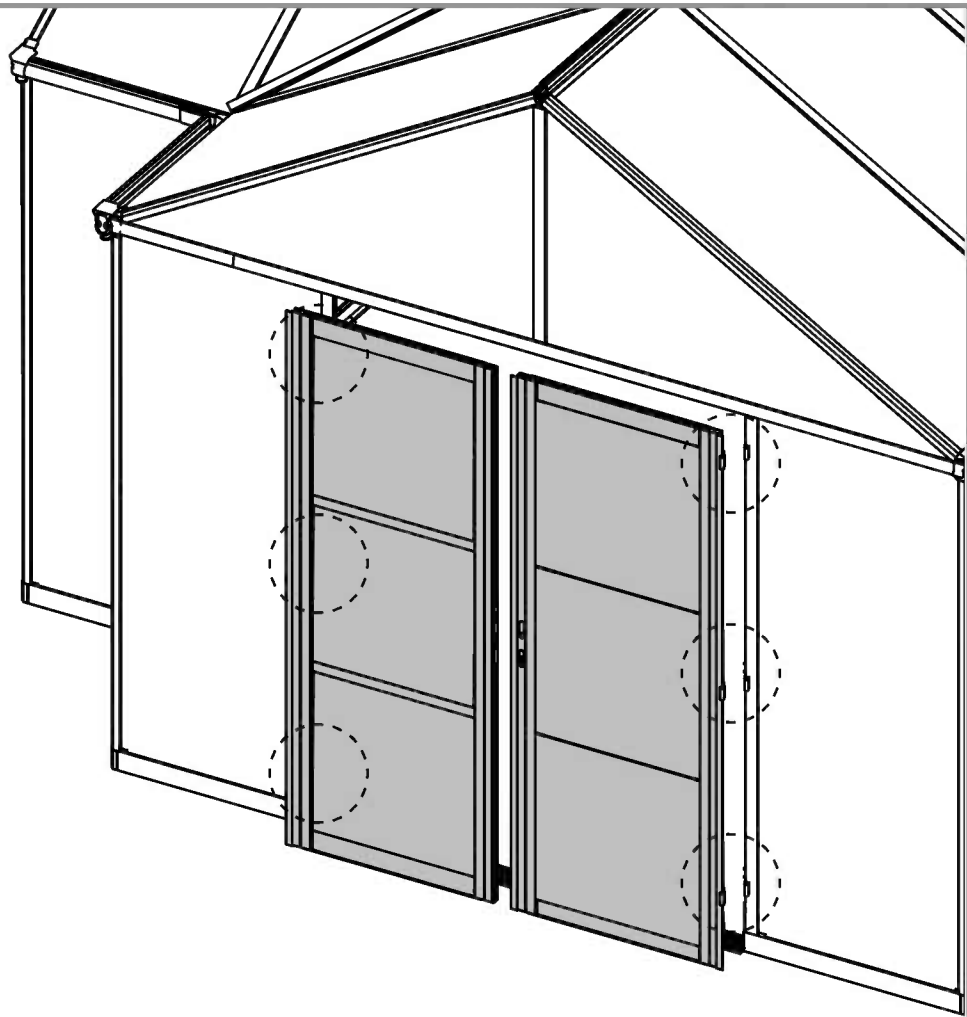
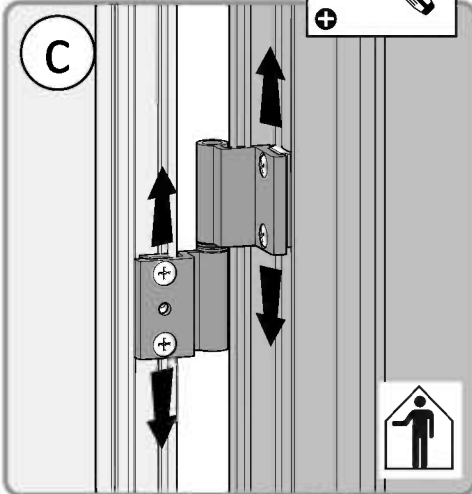
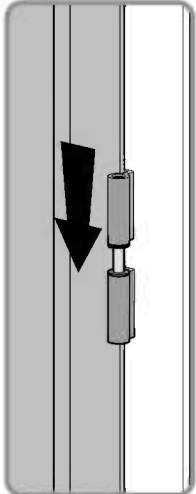
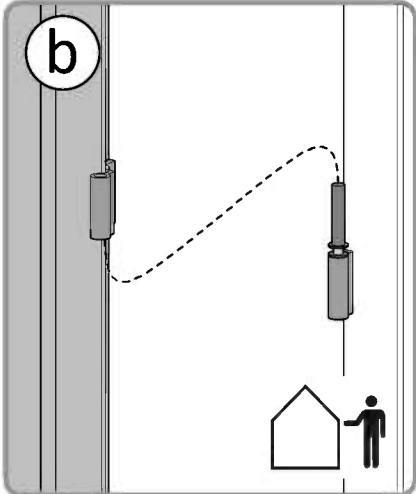
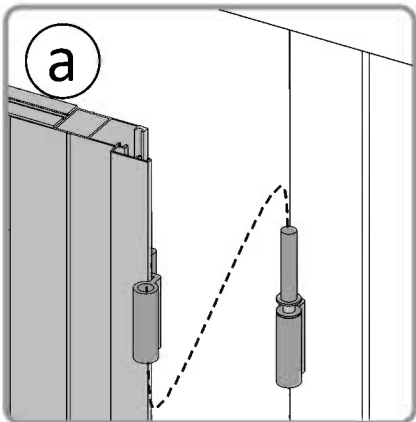
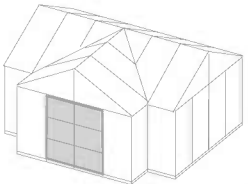

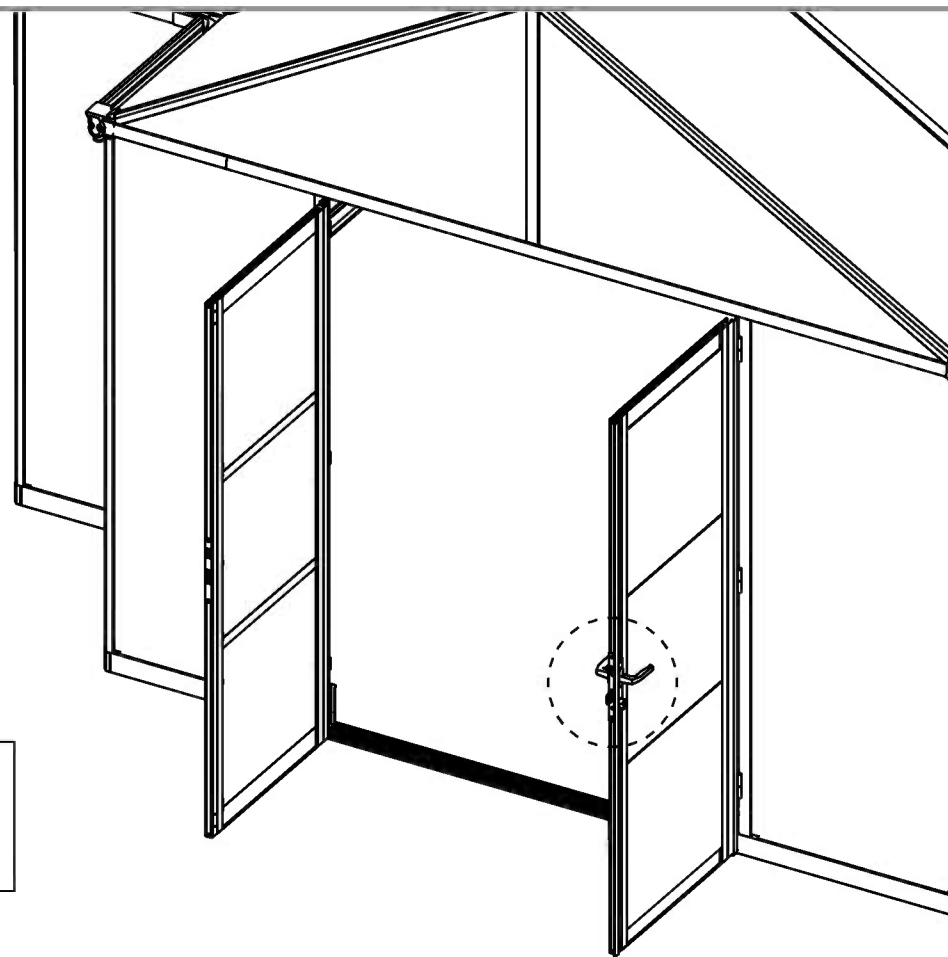
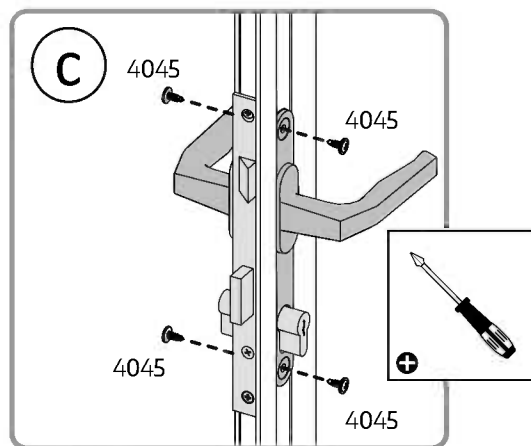
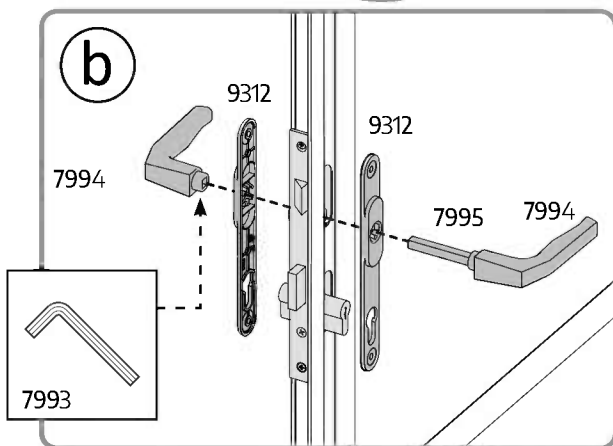
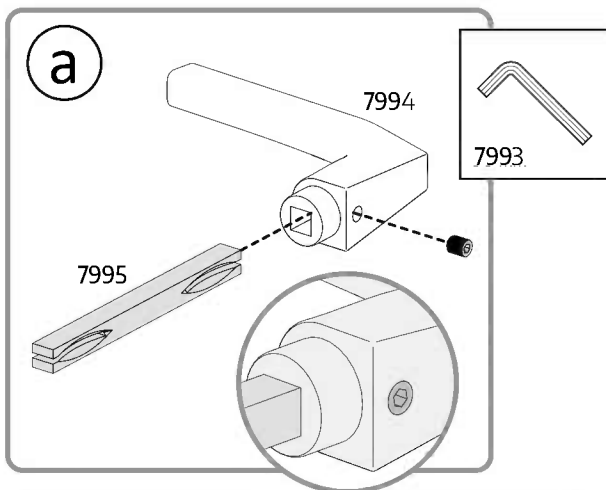
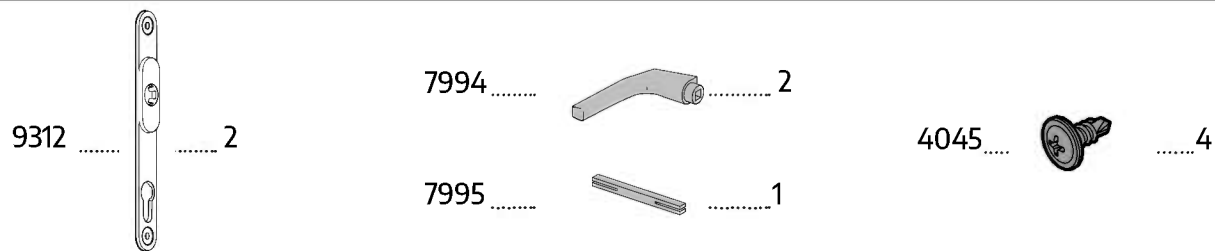
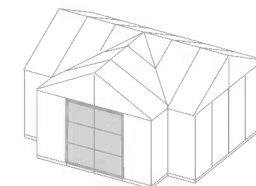

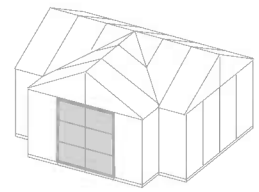

9707 2

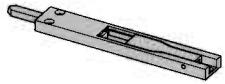

9708 6

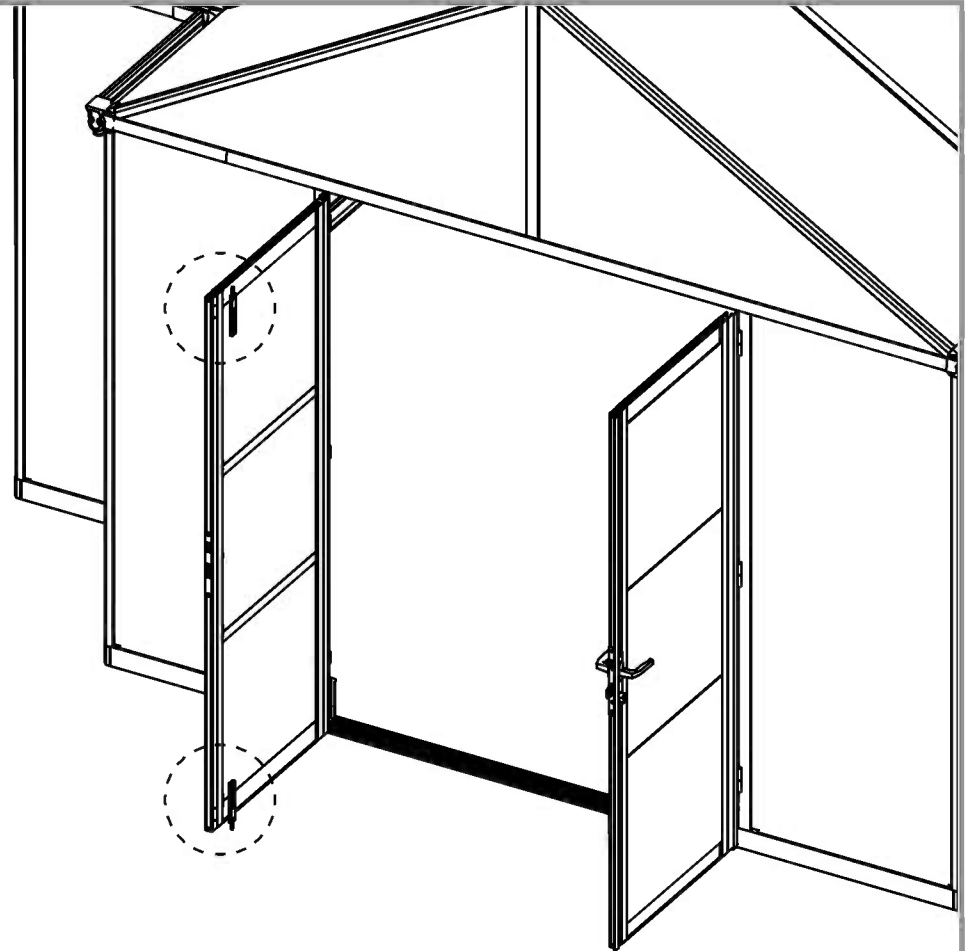
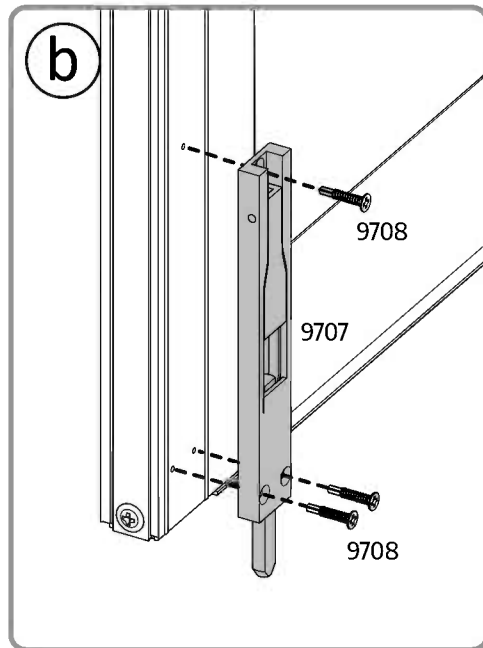
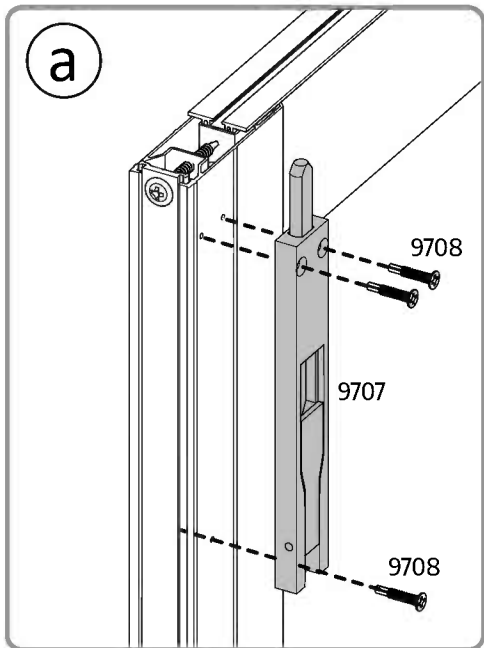
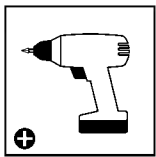



Make sure the base is square by measuring the diagonals and level by using a spirit level.
Anchoring this product to the ground is essential to its stability and rigidity. It is required to complete this stage in order for your warranty to be valid.

The supplied screws and fasteners are suitable for concrete floor only. If the product is fixed to a different type of floor, consult with an expert regarding which fasteners are suitable for other surface types.

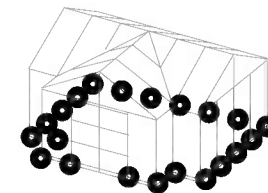

4000..... 19

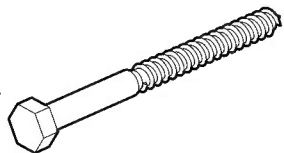

4010 19

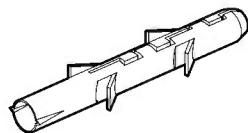

433 19

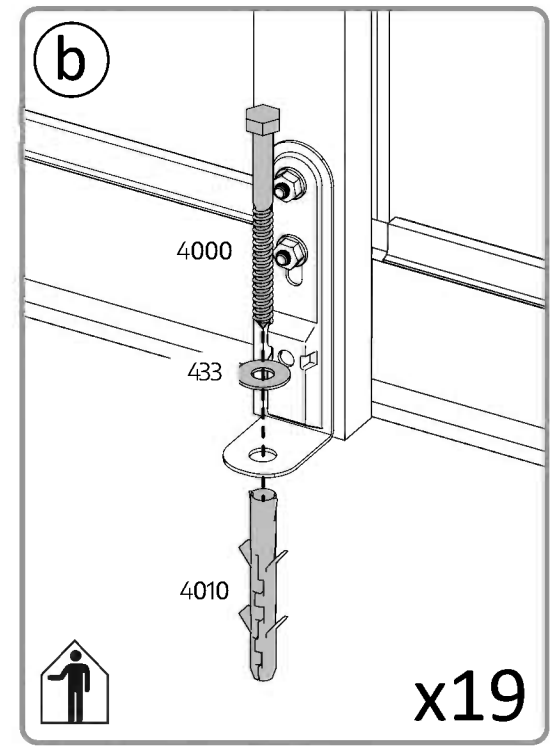
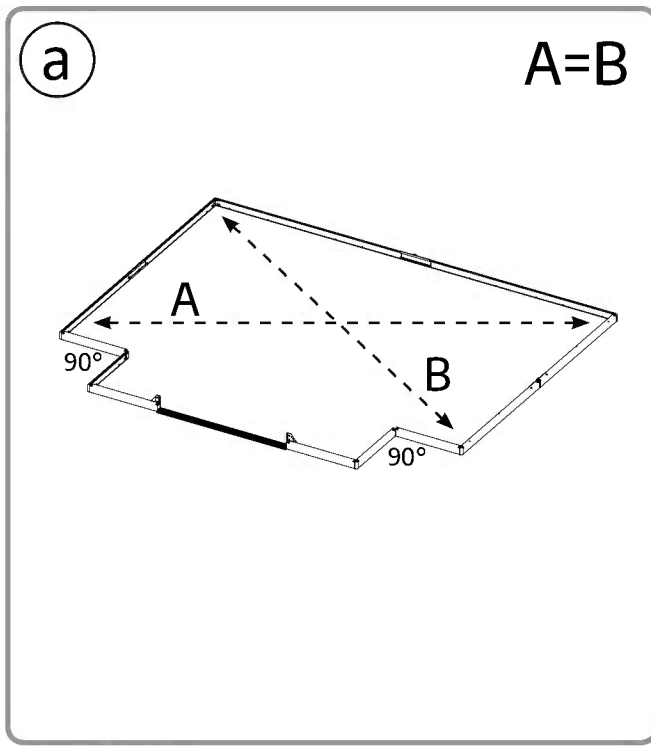
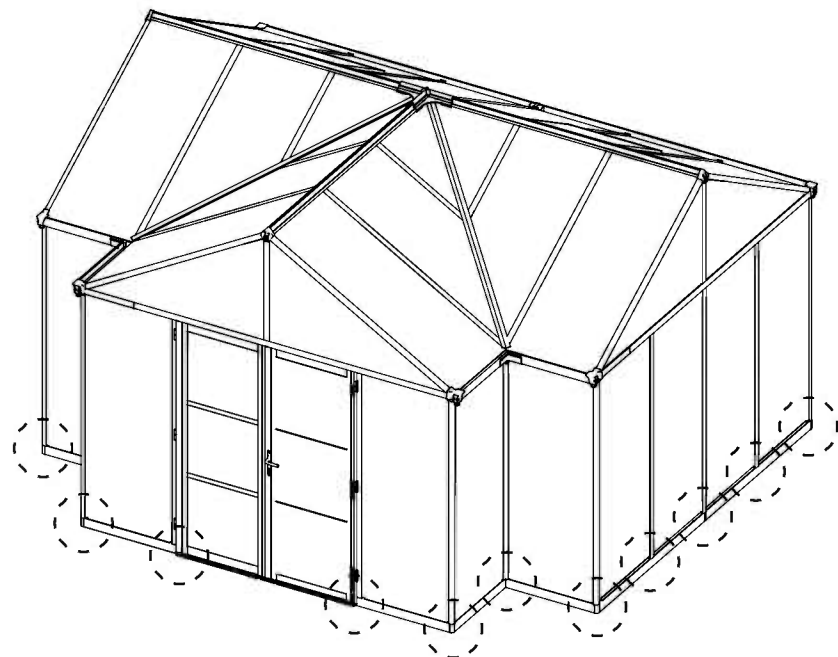
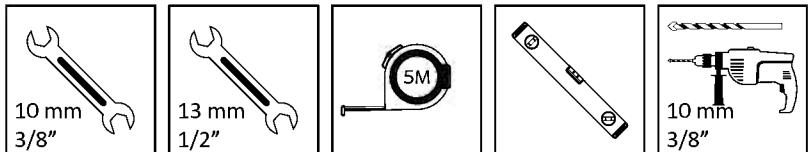

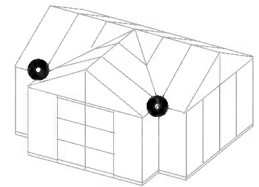

9968..... 4



8192 2



466 2



4008 4

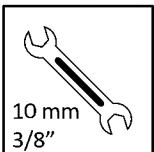
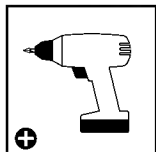
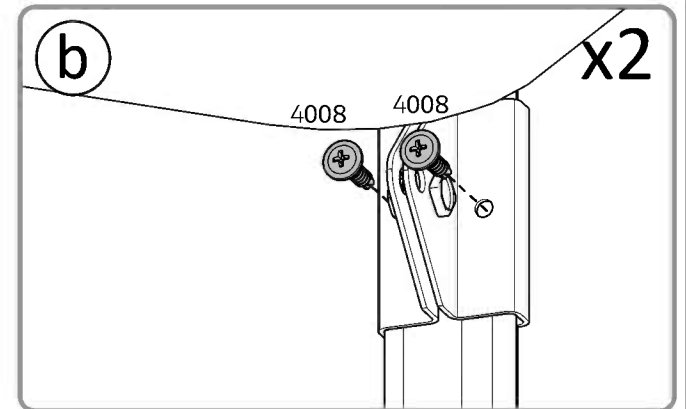
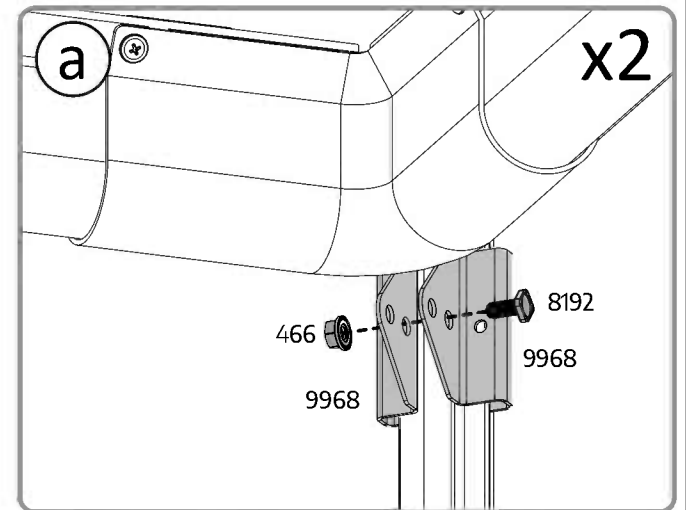
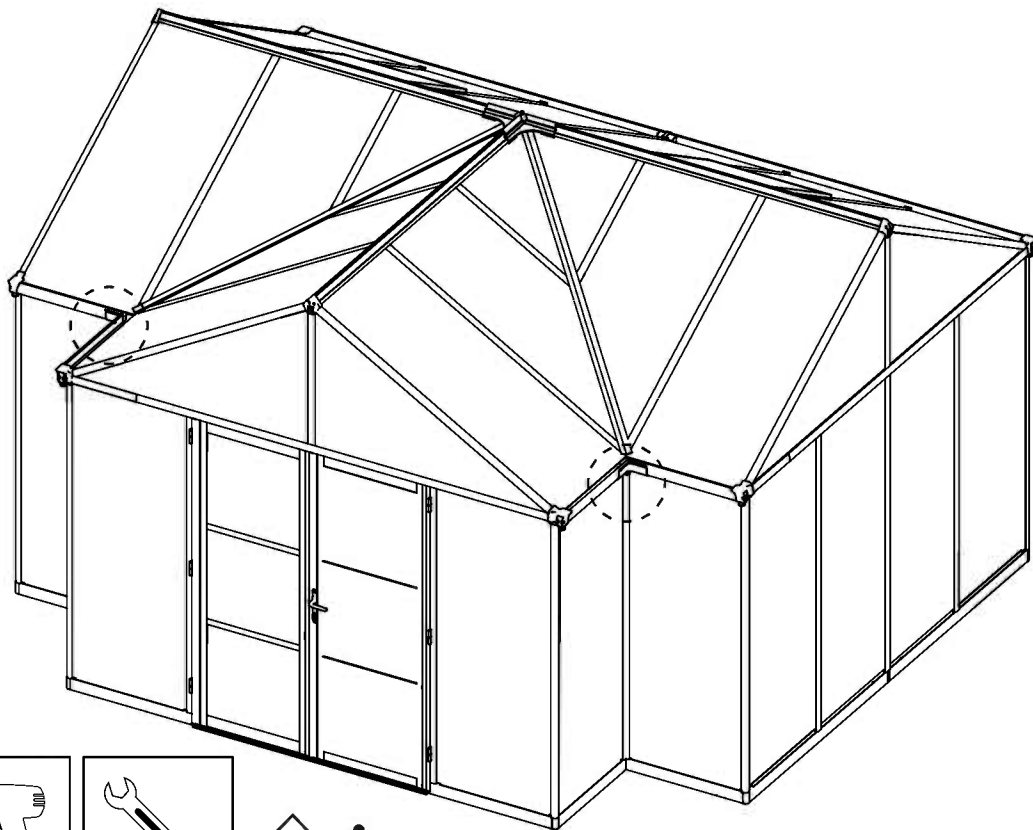
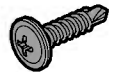

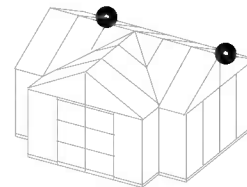

9968.....  4

8192  2

466  2

4008  4

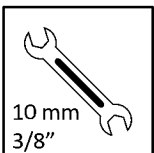
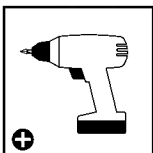
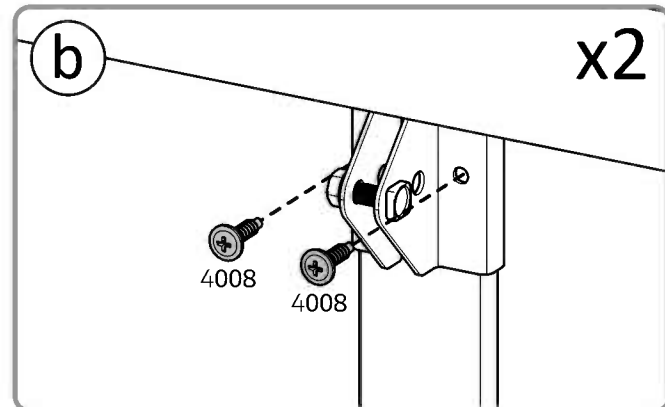
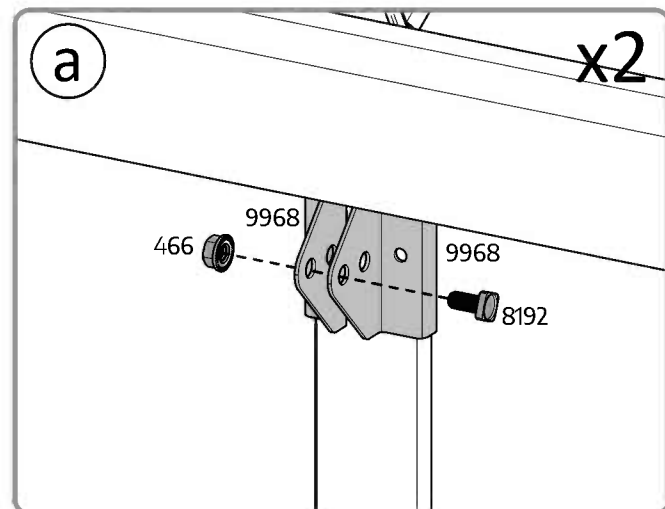
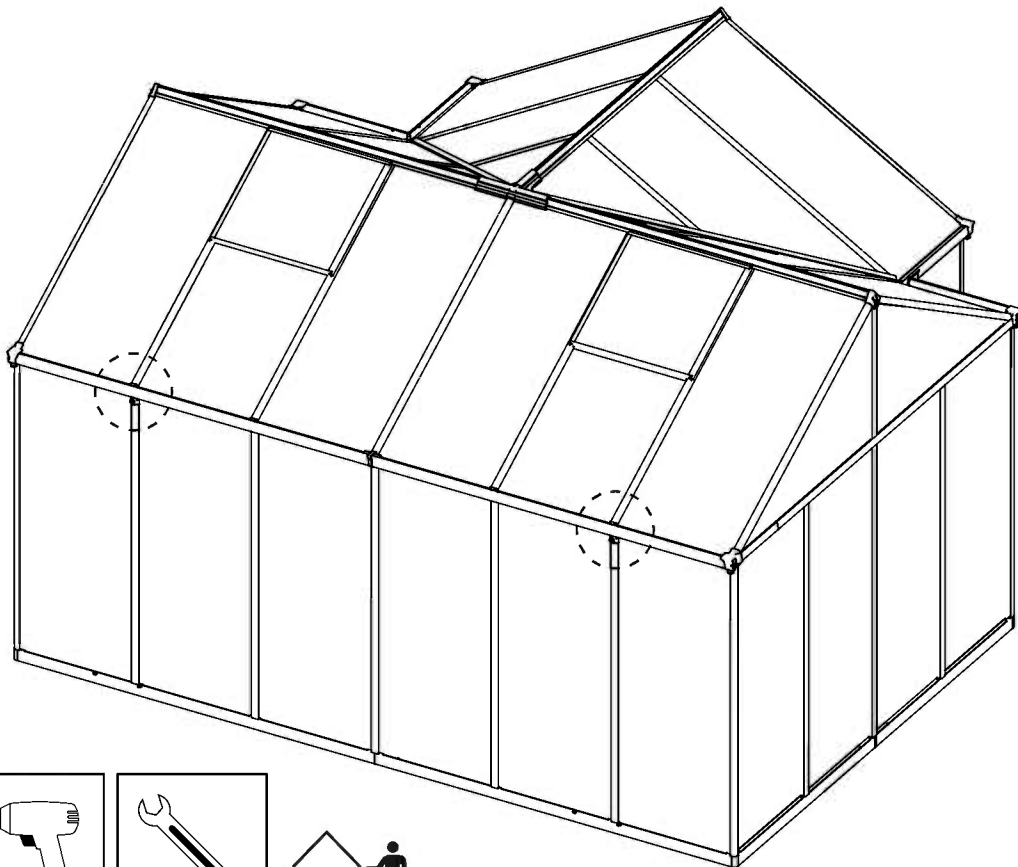

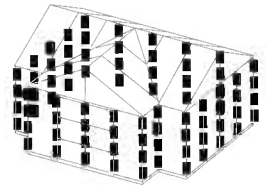

1171  40

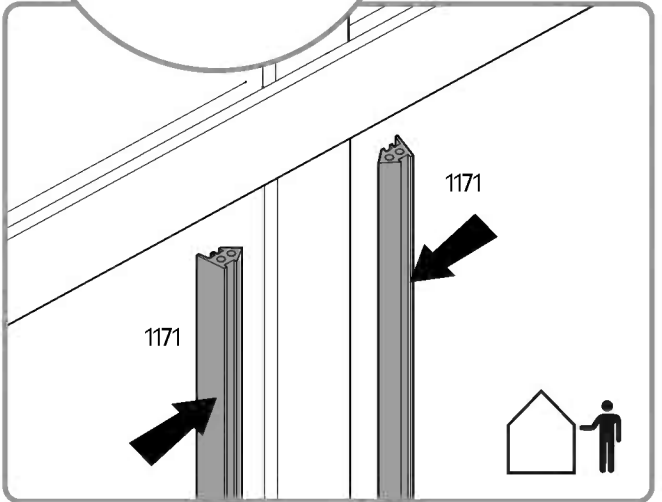
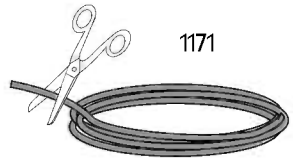
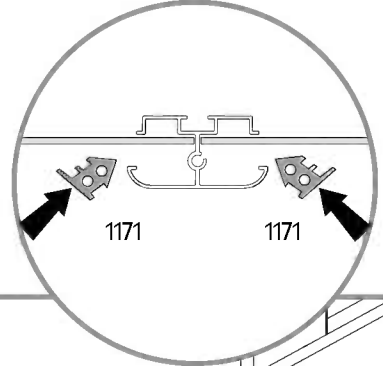
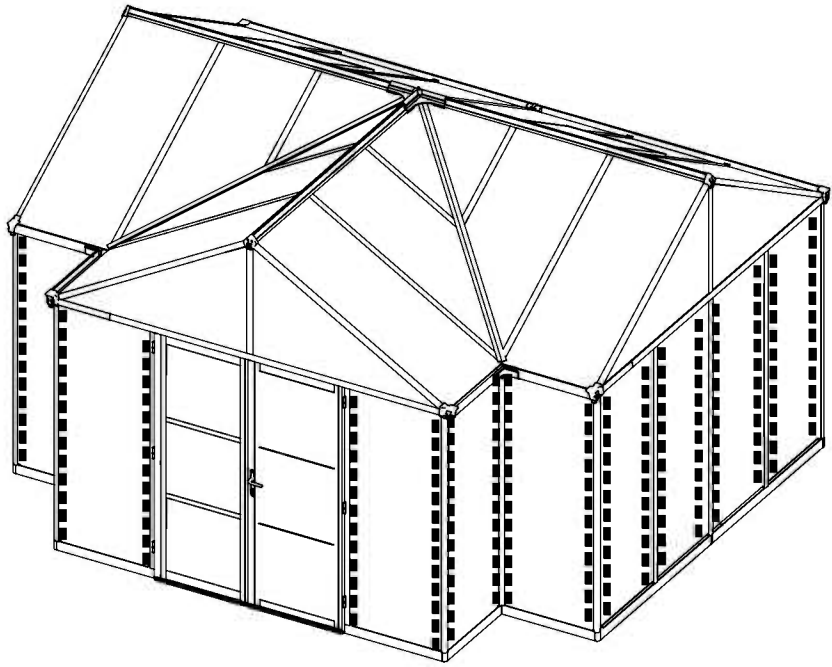
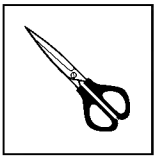

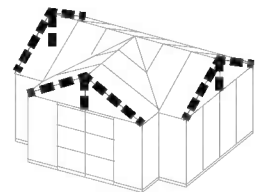

1171   10

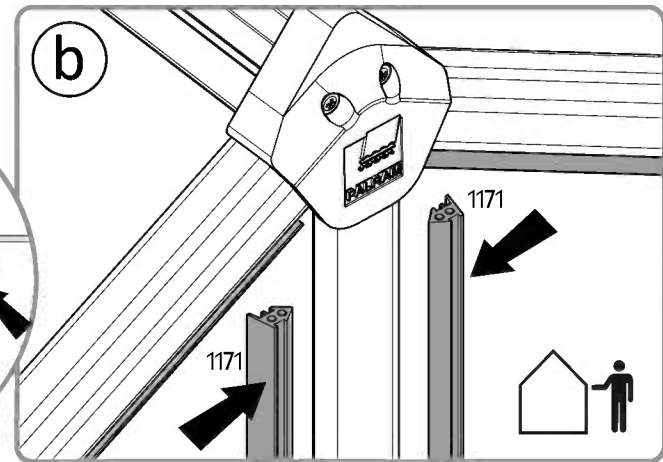
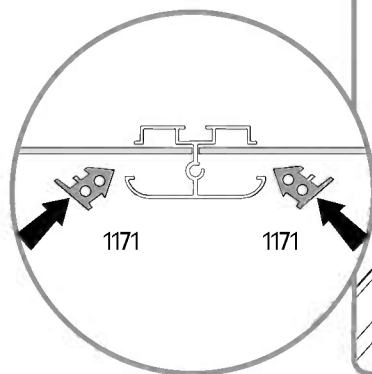
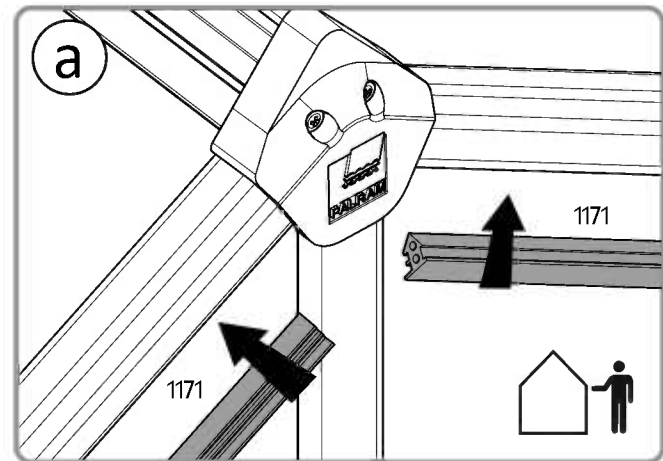
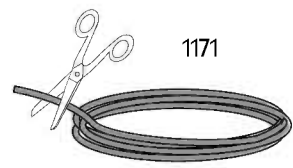
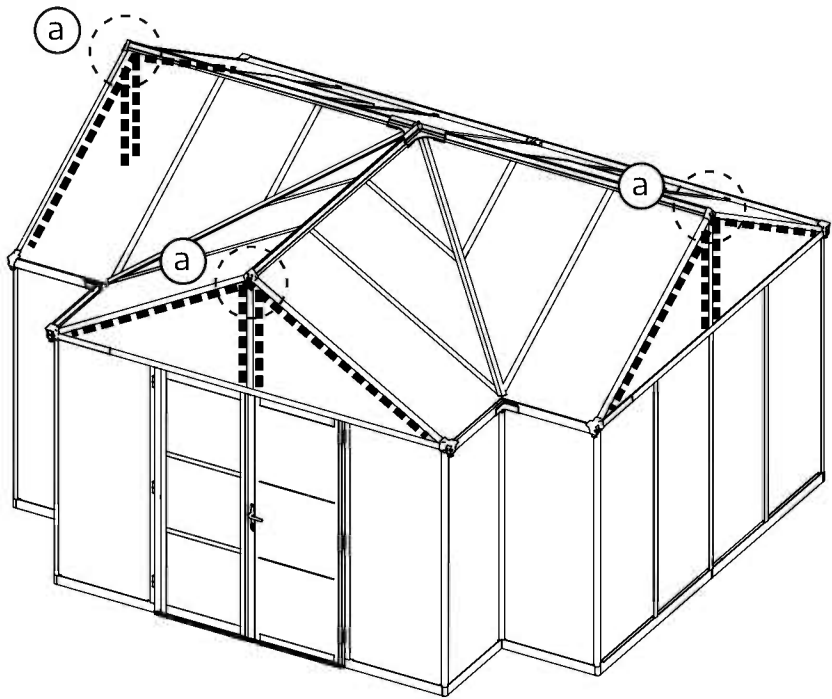
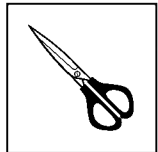

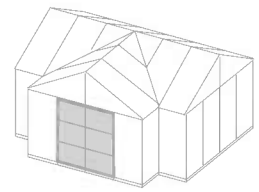

8702   4

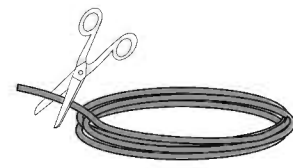
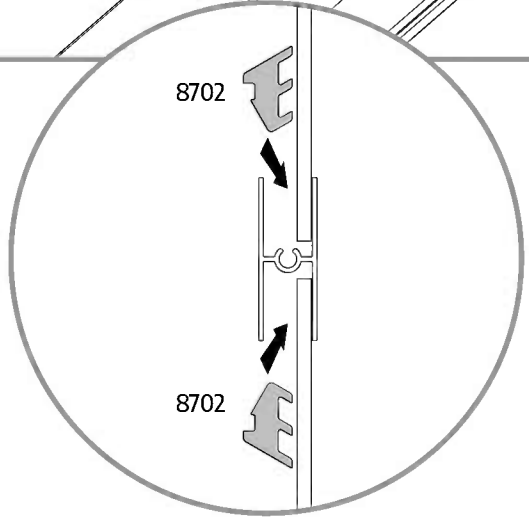
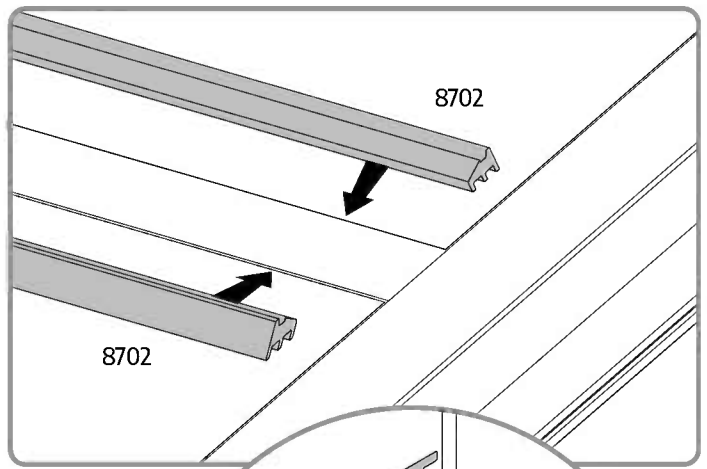
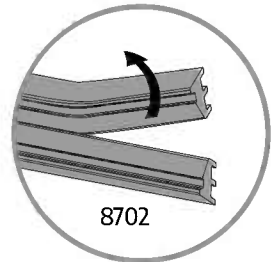
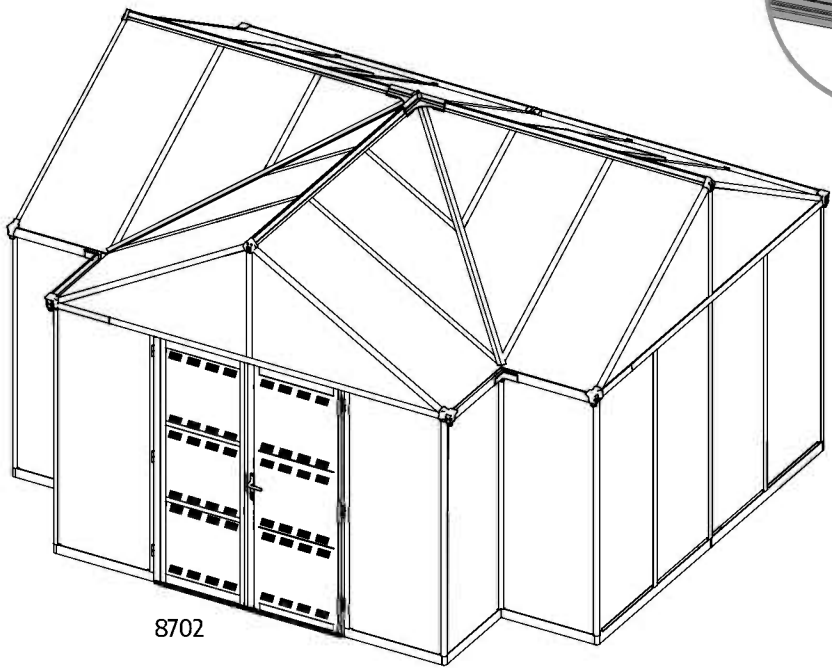
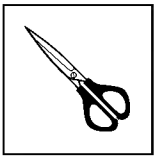



The supplied screws and fasteners are suitable for concrete floor only. If the product is fixed to a different type of floor, consult with an expert regarding which fasteners are suitable for other surface types.

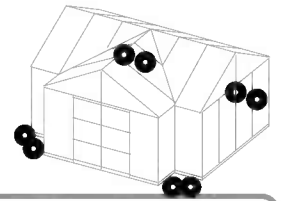

- 7331  8
- 4000  8
- 4010  8
- 433  8

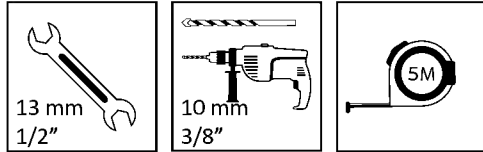
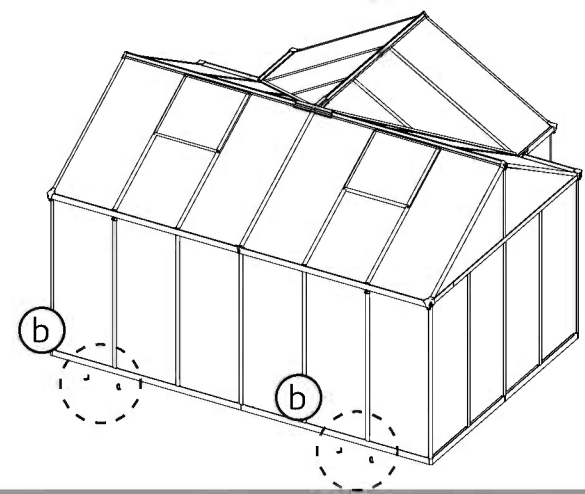
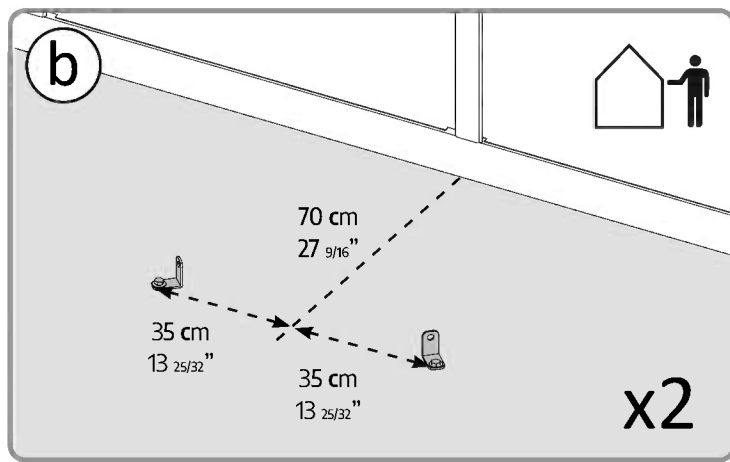
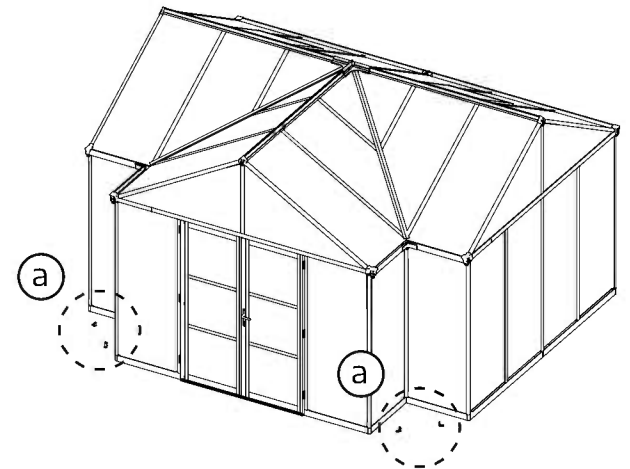
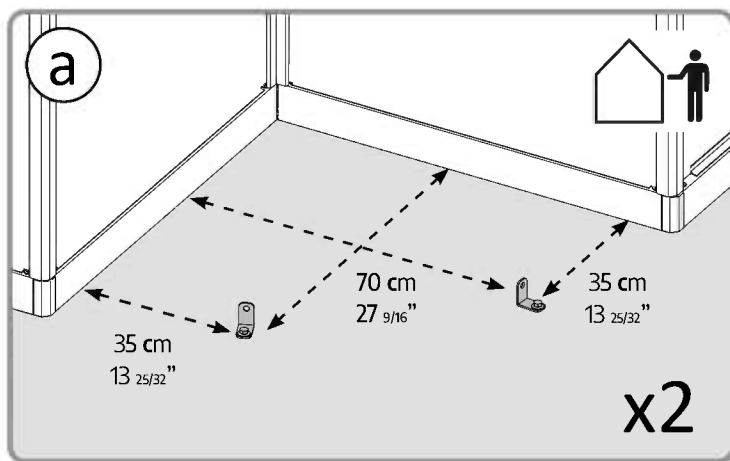
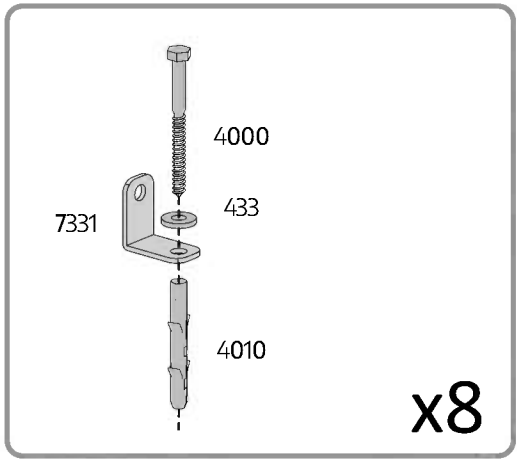

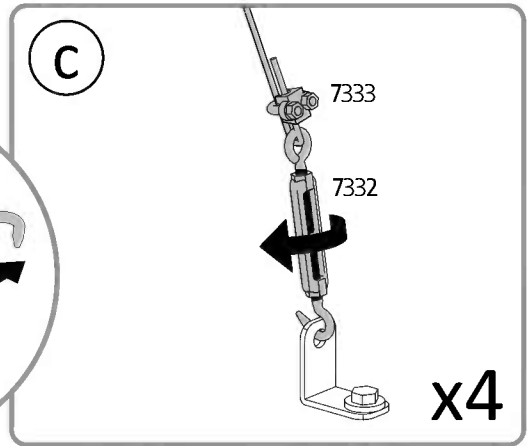
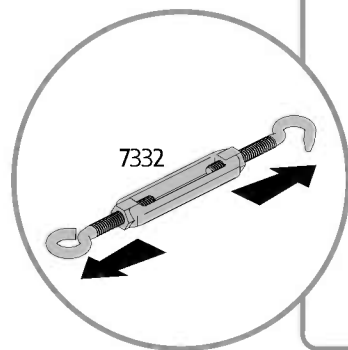
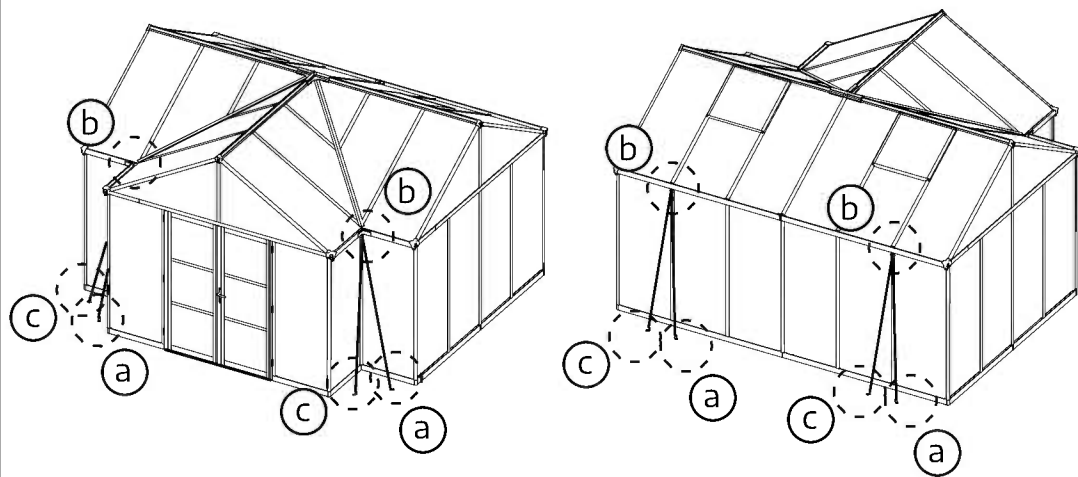
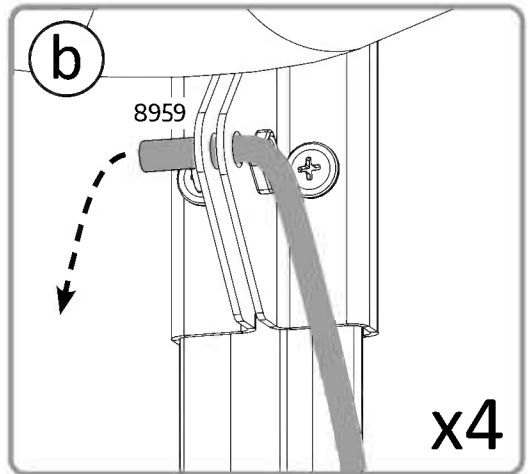
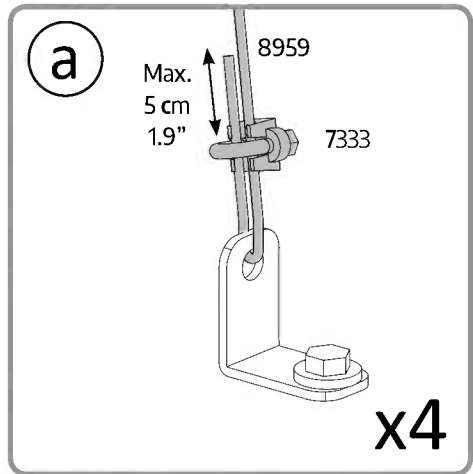
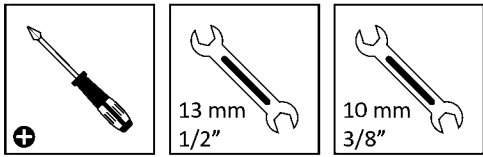
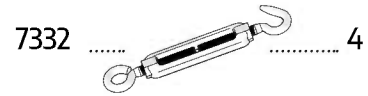
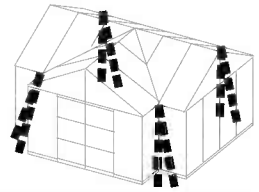



Optional for expected heavy snow load locations – For additional reinforcement, connect a wooden post in the middle of the product (the wooden post and screws are not supplied). The wooden post must be prepared according to the dimensions in **Drawing a**, then anchored to a solid surface with supplied masonry anchors #9227.

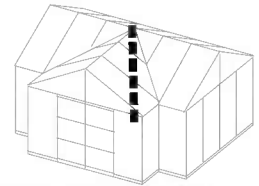

9227 4



a

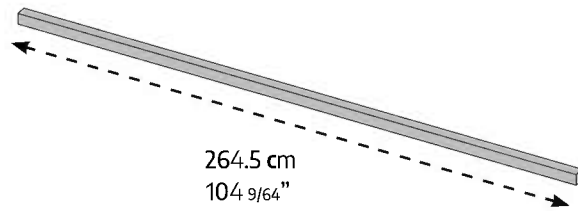

264.5 cm
104 9/64"

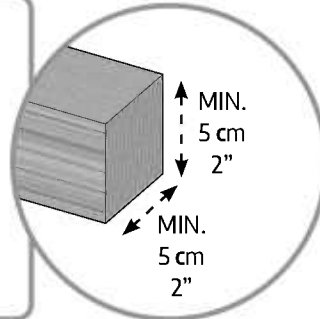

MIN.
5 cm
2"
MIN.
5 cm
2"

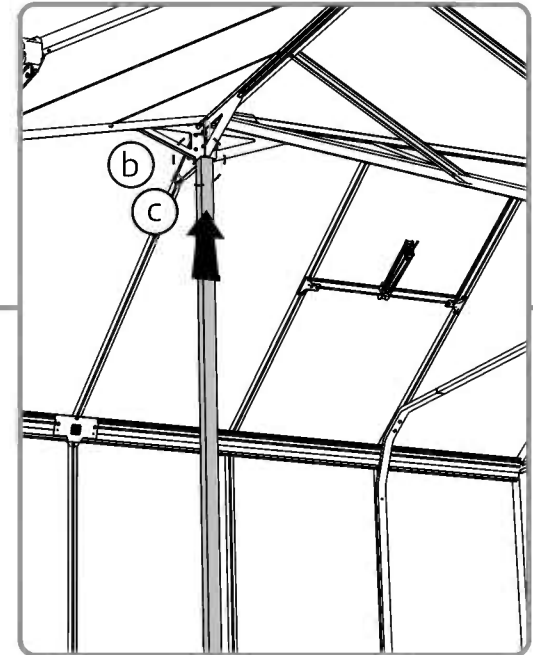

b

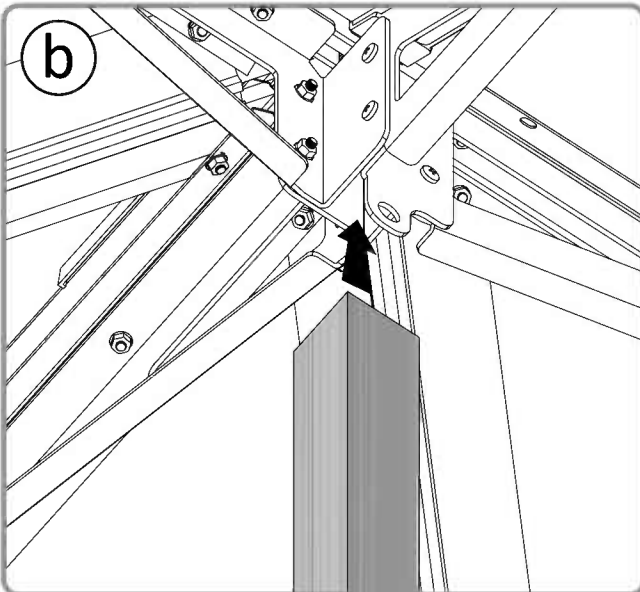

c

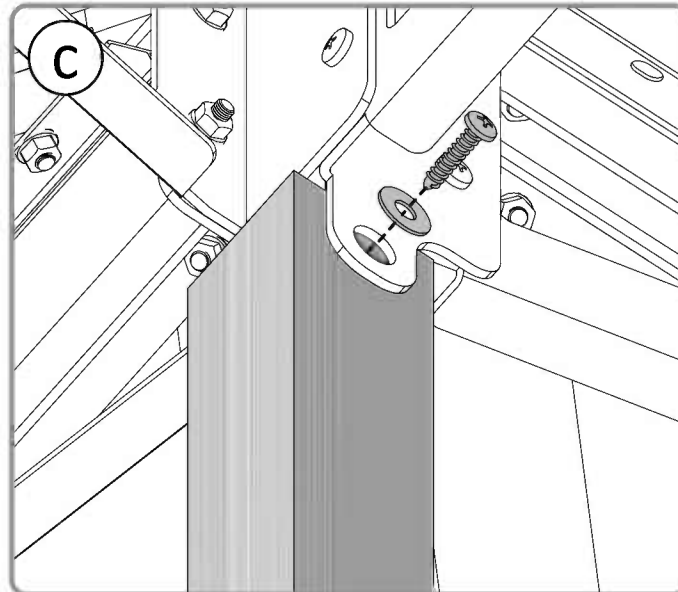

d

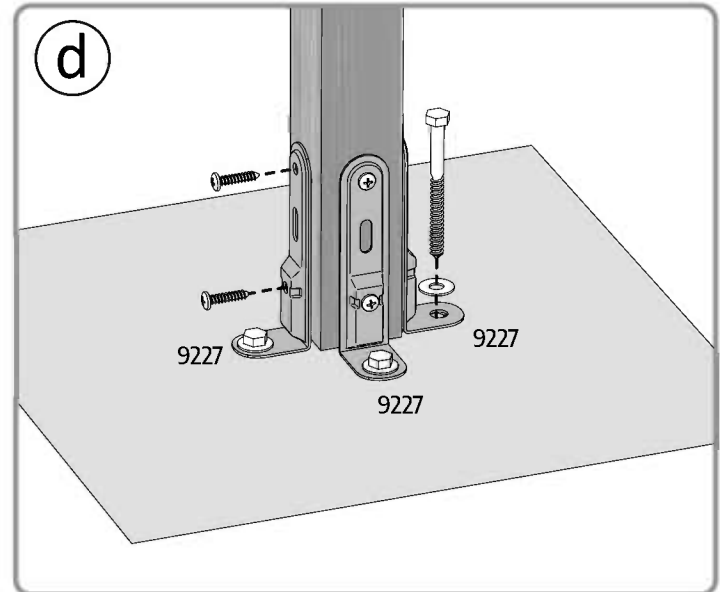

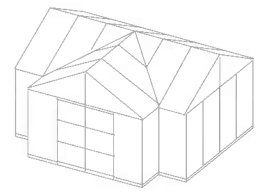

5001 238



..... 238

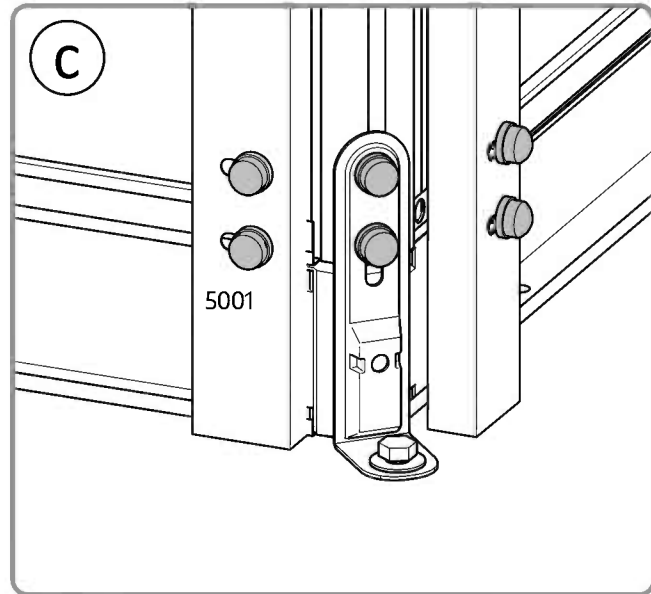
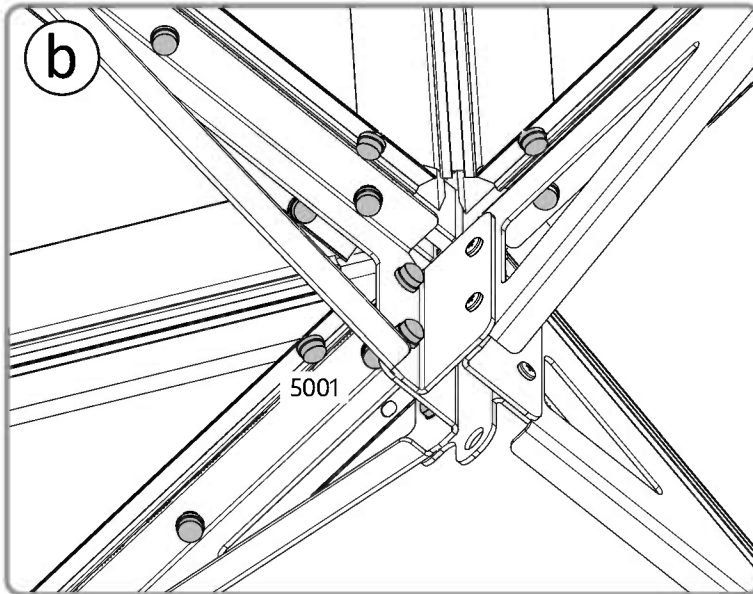
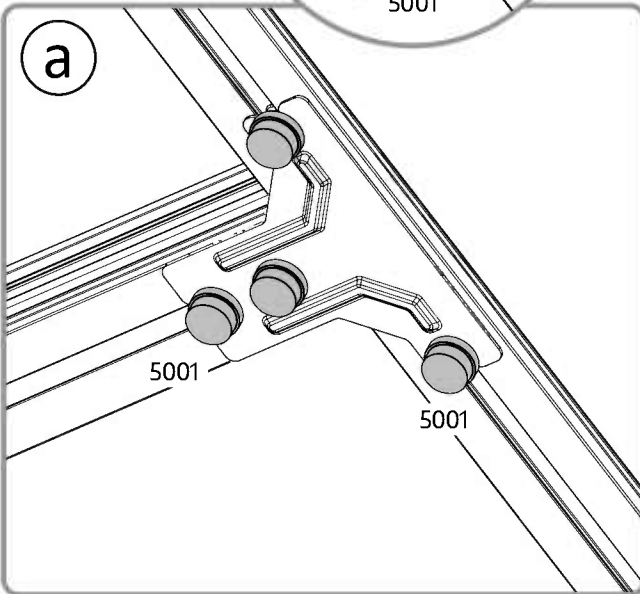
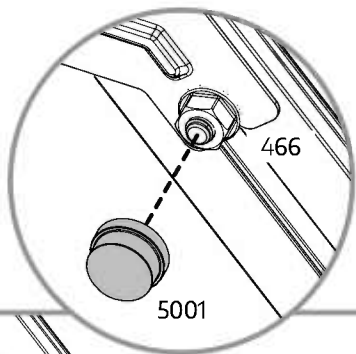

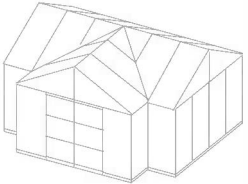

5000.....

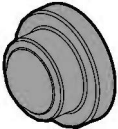

..... 19

